

NATIONAL
CABLES
INDUSTRY

NCI

الوطنية
لصناعة
الكابلات

Committed Quality for our Customers

WIRES & WIRING CABLES

INNOVATIVE

PROCESSES AND
TECHNOLOGY STRATEGIES

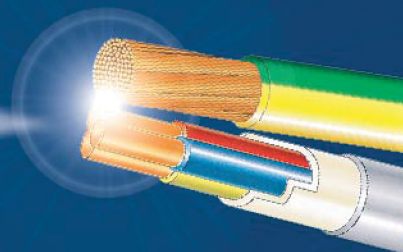

Table of contents

1)	Introduction	02
2)	CU/PVC Wires 450/750 Volts Round Solid (Class 1)...H07V-U.....	04
3)	CU/PVC Wires 450/750 Volts - Round Stranded (Class 2)...H07V-R.....	05
4)	CU/PVC Wires 450/750 Volts - Round Flexible (Class 5)... H07V-K.....	06
5)	Heat Resistant CU/PVC Wires as per BS 6231 Type CK.....	07
6)	CU/LSZH Wires 450/750 Volts - Round Solid (Class 1)...H07Z-U.....	09
7)	CU/LSZH Wires 450/750 Volts - Round Stranded (Class 2)...H07Z-R	10
8)	CU/LSZH Wires 450/750 Volts - Round Flexible (Class 5)...H07Z-K... ..	11
9)	CU/PVC/PVC Cables 300/500 Volts - Round Solid...H05VV-U.....	12
10)	CU/PVC/PVC Cables 300/500 Volts - Round Stranded...H05VV-R.....	13
11)	CU/PVC/PVC Cables 300/500 Volts - Round Flexible...H05VV-F & H05V2V2-F.....	14
12)	CU/PVC Single Core And Twisted Twin 300/500 Volts.. H05V-K	15
13)	380 V NYFAF – PVC Insulation, Non-Sheathed Flexible Cords.....	15
14)	CU/PVC Parallel 300/300 V Twin Flexible Cords- H03VH-H	16
15)	380 V PVC Insulated, PVC Sheathed Flat NYIFY	17
16)	CU/PVC/PVC 300/500 V Flat Cables Without Earth Continuity Conductor.....	18
17)	CU/PVC/PVC 300/500 V Flat Cables With Earth Continuity Conductor.....	19
18)	THHN, THWN, TFFN, Wires.....	20
19)	Current Ratings Tables	24
20)	Current Rating Guidelines.....	28



INTRODUCTION

Power is the driving force of industries and the focus of advanced communities and aspiring Governments.

The unlimited ambitions, adopted by the **UAE** Government were behind the establishment of National Cables Industry, contributing to power distribution and transmission in the region.

As a leading manufacturer of wires and cables and with a mission of “POWER THE NATION” **NCI** manufactures cables based on strong technological base, continual improvement and maintains high Quality standards. **NCI** has devoted itself to development and continues to make steady strides towards a brighter future in **U.A.E.** and abroad by supplying Quality products in time.

NCI specializes in manufacturing of electrical wires, low medium and high voltage cables, fire retardant cables, low smoke and halogen free cables and overhead conductors for power transmission and distribution networks in compliance with British and other International Standards such as **IEC, DIN, ASTM, ICEA, AEIC, AS, NZS,** and **NFC** etc.

Quality: Effective Quality Management System is maintained at **NCI** as a key to long term operational reliability. Stringent quality control measures are implemented during procurement, during all stages of production and during final testing. Under professional control, **NCI** has demonstrated competence by obtaining Quality Management System **ISO-9001:2008** from **BASEC**, Product Certification Requirements from **BASEC** for “Enhanced Quality Management System for Product Related Functions”, Occupational Health and Safety Management System **OHSAS 18001:2007** from **SGS**, Emirates Mark of Conformity from **Emirates Authority for Standardization and Metrology (ESMA)**.

BASEC is a government-nominated independent non-profit making organization and a leader in product certification for more than 30 years and seeks to ensure National, European and International Manufacturers and their products in cable industry reach relevant standard.

NCI, understands customers needs and requirements that apply to their specific projects, offering an unparalleled after-sales services. Our professional dedicated staff is always ready to promptly respond to clients, wherever they are.



Building wires are generally used to carry electrical current in almost every industrial, residential, commercial building. National Cables Industry (NCI) is a leading manufacturer of electrical building wire and cables in the UAE. NCI supplies both residential wire for electrical wiring in homes, apartments and manufactures wires for commercial and industrial buildings.

This catalogue lists wires, cables and cords rated 300/300V, 300/500V and 450/750V used for electric power, lighting, internal wiring , electric power, domestic, office and similar environments as specified in IEC 60227, BS EN 50525-2-31 (BS 6004), BS EN 50525-2-11 (BS 6500), BS 6231 and BS EN 50525-3-41 (BS 7211).

In addition to the above, National Cables Industry manufactures variety of cables and conductors to National and International Standards to meet specific customer needs and specifications.



C U/PVC WIRES 450/750 VOLTS (ROUND SOLID)

Copper Conductor PVC insulation, BS EN 50525-2-31 (BS 6004) and IEC 60227

H07V-U as per BS EN 50525-2-31 (BS 6004) Type IEC 01 as per IEC 60227
 Conductor: Round Solid (Class 1)
 Insulation: PVC – Type TI 1 as per BS EN 50525-2-31 (BS 6004), Type C as per IEC 60227
 Based on special request, PVC insulation rated 85°C and 90°C (105°C for reduced duration) can also be provided.



For internal wiring of equipment rated voltage up to 1000 V AC and up to 750 V DC to earth.

Nominal Cross Section	Conductor (Solid)		Nominal Thickness of Insulation	Approx. Overall Diameter	Weight of Finished Cable (Approx)	Maximum Conductor DC Resistance at 20°C	Standard Packing Length
	Number of Wires in Conductor	Approx. Diameter of Conductor					
mm ²		mm	mm	mm	Kg / Km	Ohm / Km	
1 x 1.5	1	1.38	0.7	2.8	20	12.1	100 Yards
1 x 2.5	1	1.78	0.8	3.4	32	7.41	100 Yards
1 x 4	1	2.25	0.8	3.9	47	4.61	100 Yards
1 x 6	1	2.76	0.8	4.4	65	3.08	100 Yards
1 x 10	1	3.57	1.0	5.6	110	1.83	100 Yards

Color: green/yellow blue black green red yellow brown grey orange white

Packing: 100 Yards in Coils or Spools

Based on specific requirement, wires can also be supplied in km lengths in wooden or steel drums.



C U/PVC WIRES 450/750 VOLTS (ROUND STRANDED)

Copper Conductor, PVC insulation, BS EN 50525-2-31 (BS 6004) and IEC 60227

H07V-R as per BS EN 50525-2-31 (BS 6004), Type IEC 01 as per IEC 60227

Conductor: Round Stranded (Class 2)

Insulation: PVC – Type TI 1 as per BS EN 50525-2-31 (BS 6004), Type C as per IEC 60227

Based on special request, PVC insulation rated 85°C and 90°C (105°C for reduced duration) can also be provided.



For internal wiring of equipment rated voltage up to 1000 V AC and up to 750 V DC to earth.

Nominal Cross Section	Conductor (Stranded)		Nominal Thickness of Insulation	Approx. Overall Diameter	Weight of Finished Cable (Approx)	Maximum Conductor DC Resistance at 20°C	Standard Packing Length
	Number of Wires in Conductor	Approx. Diameter of Conductor					
mm ²		mm	mm	mm	Kg / Km	Ohm / Km	
1 x 1.5	7	1.56	0.7	3.0	21	12.1	100 Yards
1 x 2.5	7	1.98	0.8	3.6	33	7.41	100 Yards
1 x 4	7	2.52	0.8	4.1	48	4.61	100 Yards
1 x 6	7	3.12	0.8	4.7	68	3.08	100 Yards
1 x 10	7	4.01	1.0	6.0	113	1.83	100 Yards
1 x 16	7	5.03	1.0	7.0	170	1.15	100 Yards
1 x 25	7	6.30	1.2	8.7	265	0.727	100 Yards
1 x 35	7	7.44	1.2	9.8	361	0.524	100 Yards
1 x 50	19	8.10	1.4	10.9	470	0.387	3000 Drum
1 x 70	19	9.70	1.4	12.5	660	0.268	3000 Drum
1 x 95	19	11.40	1.6	14.6	920	0.193	3000 Drum
1 x 120	37	12.90	1.6	16.1	1140	0.153	2000 Drum
1 x 150	37	14.30	1.8	17.9	1410	0.124	2000 Drum
1 x 185	37	16.00	2.0	20.0	1770	0.0991	2000 Drum
1 x 240	61	18.40	2.2	22.8	2320	0.0754	1000 Drum
1 x 300	61	20.40	2.4	25.2	2900	0.0601	1000 Drum
1 x 400	61	23.20	2.6	28.4	3700	0.0470	500 Drum
1 x 500	61	26.70	2.8	32.3	4730	0.0366	500 Drum
1 x 630	61	30.40	2.8	36.0	6050	0.0283	500 Drum

Color: green/yellow blue black green red yellow brown grey orange white

Based on specific requirement, wires can also be supplied in km lengths in wooden or steel drums.



C U/PVC WIRES 450/750 VOLTS (ROUND FLEXIBLE)

Copper Conductor PVC insulation, BS EN 50525-2-31 (BS 6004) and IEC 60227

H07V-K as per BS EN 50525-2-31 (BS 6004) Type IEC 02 as per IEC 60227

Conductor: Flexible (Class 5)

Insulation: PVC – Type TI 1 as per BS EN 50525-2-31 (BS 6004), Type C as per IEC 60227

Based on special request, PVC insulation rated 85°C and 90°C (105°C for reduced duration) can also be provided.



For internal wiring of equipment rated voltage up to 1000 V AC and up to 750 V DC to earth.

Nominal Cross Section	Conductor (Round Flexible)		Nominal Thickness of Insulation	Approx. Overall Diameter	Weight of Finished Cable Approx.	Maximum Conductor DC Resistance at 20°C	Standard Packing Length
	Numbers of Wires in Conductor	Diameter of Conductor Approx.					
mm ²	No x mm	mm	mm	mm	Kg / Km	Ohm / Km	
1 x 1.5	27 x 0.25	1.55	0.7	3.0	20	13.3	100 C
1 x 2.5	45 x 0.25	2.00	0.8	3.6	30	7.98	100 C
1 x 4	50 x 0.30	2.51	0.8	4.2	45	4.95	100 C
1 x 6	76 x 0.30	3.09	0.8	4.7	65	3.30	100 C
1 x 10	74 x 0.40	4.07	1.0	6.1	110	1.91	100 C
1 x 16	118 x 0.40	5.08	1.0	7.1	165	1.21	100 C
1 x 25	182 x 0.40	6.35	1.2	9.0	255	0.780	100 C
1 x 35	257 x 0.40	7.50	1.2	10.0	345	0.554	100 C
1 x 50	371 x 0.40	8.95	1.4	12.0	495	0.386	1000 D
1 x 70	336 x 0.50	10.70	1.4	14.0	690	0.272	1000 D
1 x 95	444 x 0.50	12.30	1.6	16.0	910	0.206	1000 D
1 x 120	568 x 0.50	14.00	1.6	17.2	1150	0.161	1000 D
1 x 150	708 x 0.50	15.60	1.8	19.2	1435	0.129	1000 D
1 x 185	864 x 0.50	17.20	2.0	21.2	1745	0.106	1000 D
1 x 240	1134 x 0.50	20.00	2.2	24.4	2265	0.0801	1000 D
1 x 300	1414 x 0.50	22.00	2.4	27.0	2815	0.0641	1000 D

Color: green/yellow blue black green red yellow brown grey orange white



C U/PVC WIRES 600/1000 VOLTS

Copper Conductor PVC insulation, BS 6231, Type CK

Conductor: Flexible Stranded (Class 5)

Insulation: PVC – Type TI 3 rated for 90°C (105°C for reduced duration) as per BS 6231 and Type E as per IEC 60227.

These wires are high temperature heat resistant wires, intended for use in the wiring of switch control, metering, relay and instrument panels of power switchgears and for internal connections in rectifier equipment and its motor starters and controllers. They are intended for use at alternating voltages not exceeding 600V to earth and direct voltage not exceeding 1000V to earth.



Nominal Cross Section	Conductor (Flexible)		Nominal Thickness of Insulation	Approx. Overall Diameter	Weight of Finished Cable Approx.	Maximum Conductor DC Resistance at 20°C	Standard Packing Length
	Numbers of Wires in Conductor	Diameter of Conductor Approx.					
mm ²	No x mm	mm	mm	mm	Kg / Km	Ohm / Km	
1 x 1.5	27 x 0.25	1.55	0.8	3.0	20	13.3	100 C
1 x 2.5	45 x 0.25	2.0	0.8	3.6	30	7.98	100 C
1 x 4	50 x 0.30	2.5	0.8	4.11	45	4.95	100 C
1 x 6	76 x 0.30	3.09	0.8	4.7	65	3.30	100 C
1 x 10	74 x 0.40	4.07	1.0	6.1	110	1.91	100 C
1 x 16	118 x 0.40	5.08	1.0	8.0	165	1.21	100 C
1 x 25	182 x 0.40	6.4	1.2	9.0	255	0.780	100 C
1 x 35	257 x 0.40	7.5	1.2	10.0	345	0.554	100 C
1 x 50	371 x 0.40	8.95	1.4	12.0	495	0.386	1000 D
1 x 70	336 x 0.50	10.7	1.4	13.5	690	0.272	1000 D
1 x 95	444 x 0.50	12.3	1.6	15.5	910	0.206	1000 D
1 x 120	568 x 0.50	14.0	1.6	17.2	1150	0.161	1000 D
1 x 150	708 x 0.50	15.6	1.8	19.2	1435	0.129	1000 D
1 x 185	864 x 0.50	17.2	2.0	21.2	1745	0.106	1000 D
1 x 240	1134 x 0.50	20.0	2.2	24.4	2265	0.0801	1000 D

Color: green/yellow blue black green red yellow brown grey orange white



Fire is a complex and emotive subject, the consequences of fire can be catastrophic. The nature of organic material used in the manufacture of cables and possible installation conditions in areas of the fire risk can lead to a situation where cables may contribute to the spread of fire, emission of smoke and release of combustion products injurious to equipment and human health.

In power stations, hospitals, theatres, hotels and other large public buildings, the loss of visibility caused by smoke evolved from burning cable materials can cause panic and create serious problems when evacuating personnel. Location of the fire source and fire fighting are also greatly hampered by smoke. Additionally the presence of corrosive gases in the smoke result in damage and failure of sensitive electrical equipment and may initiate long term deterioration of structures, as well as being injurious to the health of personnel even after short exposure.

Awareness of this situation has led to the development of new cable technologies and introduction by major cable users of cable types with low emission of smoke, corrosive and toxic fumes and reduced flame propagation properties.

In considering cable systems with improved fire performance characteristics it is useful to first consider the various aspects of the effect of fire on a cable.

- Propagation of fire along cable runs
- Evolution of smoke leading to obstruction of exits
- Evolution of acid gas leading to corrosion of equipment
- Evolution of toxic fumes leading to personal injury

LSZH wires and cables use special formulation based on non-halogenated polymers in order to restrict the generation of smoke as much as possible. Materials are carefully selected and the compounds carefully designed in order to ensure the best performance of the external sheaths, which are directly exposed to fire.

LSZH wires and cables manufactured by NCI have been designed to offer improved performance in areas where smoke and fume emission in the event of a fire would cause particular problems. Compound used in LSZH cables do not contain halogen hence, do not emit halogenated acids when burnt which help in minimizing the total cost of the damage caused by fire and generate little smoke when burned. Furthermore, the rate at which this low level of smoke is released, is very much slower than that of PVC or similar halogenated polymers.

LSZH wires and cables manufactured by NCI have controlled limits of smoke evolution, when assessed by burning samples of cables in a 3 meter cube smoke chamber as per IEC 61034. Generally these combine the properties of low corrosive gas emission and low toxic gas emission as they are essentially halogen free when assessed by IEC 60754-1 and IEC 60754-2.

LSZH wire and cables are designed and manufactured to pass the following tests as per relevant IEC/BS Standard.

- Vertical flame propagation tests
- Smoke density tests
- Acidity, pH and conductivity test



CU/LSZH WIRES 450/750 VOLTS (ROUND SOLID) Copper Conductor LSZH Insulation BS EN 50525-3-41 (BS 7211)

H07Z-U as per BS EN 50525-3-41 (BS 7211)

Conductor: Round Solid (Class 1)

Insulation: Low Smoke Thermosetting Insulation Type EI5 as per BS EN 50525-3-41 (BS 7211)



For internal wiring of equipment rated voltage up to 1000 V AC and up to 750 DC earth.

Nominal Cross Section	Conductor (Solid)		Nominal Thickness of Insulation	Approx. Overall Diameter	Weight of Finished Cable (Approx)	Maximum Conductor DC Resistance at 20°C	Standard Packing Length
	Number of Wires in Conductor	Approx. Diameter of Conductor					
mm ²		mm	mm	mm	Kg / Km	Ohm / Km	
1 x 1.5	1	1.38	0.7	3.0	20	12.1	100 Yards
1 x 2.5	1	1.78	0.8	3.5	32	7.41	100 Yards
1 x 4	1	2.25	0.8	4.0	47	4.61	100 Yards
1 x 6	1	2.76	0.8	5.0	65	3.08	100 Yards
1 x 10	1	3.57	1.0	6.0	110	1.83	100 Yards

Color: green/yellow blue black green red yellow brown grey orange white



C U/LSZH WIRES 450/750 VOLTS (ROUND STRANDED)

Copper Conductor LSZH Insulation BS EN 50525-3-41 (BS 7211)

H07Z-R as per BS EN 50525-3-41 (BS 7211)

Conductor: Round Solid (Class 2)

Insulation: Low Smoke Thermosetting Insulation Type EI5 as per BS EN 50525-3-41 (BS 7211)



For internal wiring of equipment rated voltage up to 1000 V AC and up to 750 V DC to earth.

Nominal Cross Section	Conductor (Round Stranded)		Nominal Thickness of Insulation	Approx. Overall Diameter	Weight of Finished Cable Approx.	Maximum Conductor DC Resistance at 20°C	Standard Packing Length
	Numbers of Wires in Conductor	Approx. Diameter of Conductor.					
mm ²	No	mm	mm	mm	Kg / Km	Ohm / Km	Yards
1 x 1.5	7	1.56	0.7	3.0	21	12.1	100 C
1 x 2.5	7	1.98	0.8	3.6	33	7.41	100 C
1 x 4	7	2.52	0.8	4.1	48	4.61	100 C
1 x 6	7	3.12	0.8	4.7	68	3.08	100 C
1 x 10	7	4.01	1.0	6.0	113	1.83	100 C
1 x 16	7	5.03	1.0	7.0	170	1.15	100 C
1 x 25	7	6.30	1.2	8.7	265	0.727	100 C
1 x 35	7	7.44	1.2	9.8	360	0.524	100 C
1 x 50	19	8.10	1.4	10.9	470	0.387	3000 D
1 x 70	19	9.70	1.4	12.5	663	0.268	3000 D
1 x 95	19	11.40	1.6	14.6	920	0.193	3000 D
1 x 120	37	12.90	1.6	16.1	1140	0.153	2000 D
1 x 150	37	14.30	1.8	17.9	1410	0.124	2000 D
1 x 185	37	16.00	2.0	20.0	1770	0.0991	2000 D
1 x 240	61	18.40	2.2	22.8	2320	0.0754	1000 D
1 x 300	61	20.40	2.4	25.2	2900	0.0601	1000 D
1 x 400	61	23.20	2.6	28.4	3700	0.0470	500 D
1 x 500	61	26.70	2.8	32.3	4730	0.0366	500 D
1 x 630	61	30.40	2.8	36.0	6050	0.0283	500 D

Color: green/yellow blue black green red yellow brown grey orange white



CU/LSZH WIRES 450/750 VOLTS (ROUND FLEXIBLE) Copper Conductor LSZH Insulation BS EN 50525-3-41 (BS 7211)

H07Z-K as per BS EN 50525-3-41 (BS 7211)

Conductor: Round Flexible (Class5)

Insulation: Low Smoke Thermosetting Insulation Type EI5 as per BS EN 50525-3-41 (BS 7211)



For internal wiring of equipment rated voltage up to 1000 V AC and up to 750 V DC to earth.

Nominal Cross Section	Conductor (Round Flexible)		Nominal Thickness of Insulation	Approx. Overall Diameter	Weight of Finished Cable Approx.	Maximum Conductor DC Resistance at 20°C	Standard Packing Length
	Numbers of Wires in Conductor	Approx. Diameter of Conductor					
mm ²	No x mm	mm	mm	mm	Kg / Km	Ohm / Km	M ± 5%
1 x 1.5	27 x 0.25	1.55	0.7	3.0	20	13.3	100 C
1 x 2.5	45 x 0.25	2.00	0.8	3.6	30	7.98	100 C
1 x 4	50 x 0.30	2.51	0.8	4.1	45	4.95	100 C
1 x 6	76 x 0.30	3.09	0.8	4.7	65	3.30	100 C
1 x 10	74 x 0.40	4.07	1.0	6.1	110	1.91	100 C
1 x 16	118 x 0.40	5.08	1.0	7.1	165	1.21	100 C
1 x 25	182 x 0.40	6.35	1.2	9.0	255	0.780	100 C
1 x 35	257 x 0.40	7.50	1.2	10.0	345	0.554	100 C
1 x 50	371 x 0.40	8.95	1.4	12.0	495	0.386	1000 D
1 x 70	336 x 0.50	10.70	1.4	14.0	690	0.272	1000 D
1 x 95	444 x 0.50	12.30	1.6	16.0	910	0.206	1000 D
1 x 120	568 x 0.50	14.00	1.6	17.2	1150	0.161	1000 D
1 x 150	708 x 0.50	15.60	1.8	19.2	1435	0.129	1000 D
1 x 185	864 x 0.50	17.20	2.0	21.2	1745	0.106	1000 D
1 x 240	1134 x 0.50	20.0	2.2	24.4	2265	0.0801	1000 D
1 x 300	1414 x 0.50	22.0	2.4	27.0	2815	0.0641	1000 D

Color: green / yellow blue black green red yellow brown grey orange white



C U/PVC/PVC CABLES 300/500 VOLTS (ROUND SOLID)

Copper Conductor PVC insulated and PVC Sheathed - IEC 60227

H05VV-U, IEC 60227
TYPE 60227 IEC 10



Nominal Cross Section	Numbers of Wires in Conductor	Approx. Diameter of Conductor	Nominal Thickness of Insulation	Nominal Thickness of Sheath	Approx. Overall Diameter	Weight of Finished Cable Approx.	Maximum Conductor DC Resistance at 20°C	Standard Packing Length
mm ²		mm	mm	mm	mm	Kg / Km	Ohm / Km	M ± 5%
2 x 1.5	1	1.38	0.7	1.2	8.0	94	12.1	100 C
2 x 2.5	1	1.78	0.8	1.2	9.2	133	7.41	100 C
2 x 4	1	2.25	0.8	1.2	10.1	176	4.61	100 C
2 x 6	1	2.76	0.8	1.2	11.1	227	3.08	100 C
2 x 10	1	3.57	1.0	1.4	13.9	367	1.83	1000/2000
3 x 1.5	1	1.38	0.7	1.2	8.4	113	12.1	100 C
3 x 2.5	1	1.78	0.8	1.2	10.0	163	7.41	100 C
3 x 4	1	2.25	0.8	1.2	10.7	219	4.61	100 C
3 x 6	1	2.76	0.8	1.4	12.2	298	3.08	100 C
3 x 10	1	3.57	1.0	1.4	15.0	467	1.83	1000/2000
4 x 1.5	1	1.38	0.7	1.2	9.1	138	12.1	100 C
4 x 2.5	1	1.78	0.8	1.2	10.6	201	7.41	100 C
4 x 4	1	2.25	0.8	1.4	12.1	284	4.61	100 C
4 x 6	1	2.76	0.8	1.4	13.3	372	3.08	1000/2000
4 x 10	1	3.57	1.0	1.4	16.3	594	1.83	1000/2000
5 x 1.5	1	1.38	0.7	1.2	10.0	165	12.1	100 C
5 x 2.5	1	1.78	0.8	1.2	11.5	242	7.41	100 C
5 x 4	1	2.25	0.8	1.4	13.2	343	4.61	100 C
5 x 6	1	2.76	0.8	1.4	15.0	452	3.08	1000/2000
5 x 10	1	3.57	1.0	1.4	17.8	734	1.83	1000/2000

Colour of Insulation:

- 2 cores: Red, Black
- 3 cores: Red, Yellow and Blue
- 4 cores: Red, Yellow, Blue and Black
- 5 cores: Red, Yellow, Blue, Black and Green

Colour of Outer sheath – Grey.

Note: Colour code as per BS Standards shall only be provided based on specific request which is as follows:

- 2 cores: brown and blue
- 3 cores: green/yellow, blue, brown
- 4 cores: green/yellow, blue, brown, black
- 5 cores: green/yellow, blue, brown, black and grey



C U/PVC/PVC CABLES 300/500 VOLTS (ROUND STRANDED)

Copper Conductor PVC insulated and PVC Sheathed and IEC 60227

H05VV-R, IEC 60227
TYPE 60227 IEC 10



Cross Section	Numbers of Wires in Conductor	Approx. Diameter of Conductor	Nominal Thickness of Insulation	Nominal Thickness of Sheath	Approx. Overall Diameter	Weight of Finished Cable Approx.	Maximum Conductor DC Resistance at 20°C	Standard Packing Length
mm ²		mm	mm	mm	mm	Kg / Km	Ohm / Km	M ± 5%
2 x 1.5	7	1.56	0.7	1.2	8.3	100	12.1	100 C
2 x 2.5	7	1.98	0.8	1.2	9.6	140	7.41	100 C
2 x 4	7	2.52	0.8	1.2	10.7	190	4.61	100 C
2 x 6	7	3.12	0.8	1.2	11.8	246	3.08	100 C
2 x 10	7	4.01	1.0	1.4	14.8	396	1.83	1000/2000
2 x 16	7	5.03	1.0	1.4	16.9	555	1.15	1000/2000
2 x 25	7	6.30	1.2	1.4	20.0	830	0.727	1000
2 x 35	7	7.44	1.2	1.6	23.0	1210	0.524	1000
3 x 1.5	7	1.56	0.7	1.2	8.8	121	12.1	100 C
3 x 2.5	7	1.98	0.8	1.2	10.2	170	7.41	100 C
3 x 4	7	2.52	0.8	1.2	11.4	235	4.61	100 C
3 x 6	7	3.12	0.8	1.4	13.0	320	3.08	100 C
3 x 10	7	4.01	1.0	1.4	16.0	500	1.83	1000/2000
3 x 16	7	5.03	1.0	1.4	18.0	714	1.15	1000/2000
3 x 25	7	6.30	1.2	1.6	22.0	1100	0.727	1000
3 x 35	7	7.44	1.2	1.6	24.0	1440	0.524	1000
4 x 1.5	7	1.56	0.7	1.2	9.6	148	12.1	100 C
4 x 2.5	7	1.98	0.8	1.2	11.1	215	7.41	100 C
4 x 4	7	2.52	0.8	1.4	12.8	304	4.61	100 C
4 x 6	7	3.12	0.8	1.4	14.2	399	3.08	1000/2000
4 x 10	7	4.01	1.0	1.4	17.3	635	1.83	1000/2000
4 x 16	7	5.03	1.0	1.4	19.8	912	1.15	1000/2000
4 x 25	7	6.30	1.2	1.6	24.0	1400	0.727	1000
4 x 35	7	7.44	1.2	1.6	27.0	1980	0.524	1000
5 x 1.5	7	1.56	0.7	1.2	10.4	176	12.1	100 C
5 x 2.5	7	1.98	0.8	1.2	12.2	250	7.41	100 C
5 x 4	7	2.52	0.8	1.4	14.0	360	4.61	100 C
5 x 6	7	3.12	0.8	1.4	15.5	484	3.08	1000/2000
5 x 10	7	4.01	1.0	1.4	19.0	786	1.83	1000/2000
5 x 16	7	5.03	1.0	1.6	22.2	1153	1.15	1000/2000
5 x 25	7	6.30	1.2	1.6	27.0	1740	0.727	1000
5 x 35	7	7.44	1.2	1.6	30.0	2310	0.524	1000

Colour of Insulation:

- 2 cores: Red, Black
- 3 cores: Red, Yellow and Blue
- 4 cores: Red, Yellow, Blue and Black
- 5 cores: Red, Yellow, Blue, Black and Green

Colour of Outer sheath – Grey.

Note: Colour code as per BS Standards shall only be provided based on specific request which is as follows:

- 2 cores: brown and blue
- 3 cores: green/yellow, blue, brown
- 4 cores: green/yellow, blue, brown, black
- 5 cores: green/yellow, blue, brown, black and grey



C U/PVC/PVC CABLES 300/500 VOLTS

Flexible Copper Conductor PVC insulated and Sheathed, BS EN 50525-2-11 (BS 6500) and IEC 60227

H05VV-F, IEC 60227 & BS EN 50525-2-11 (BS 6500)

TYPE 60227 IEC 53

H05V2V2-F Heat Resistant Cables can be made on special request.

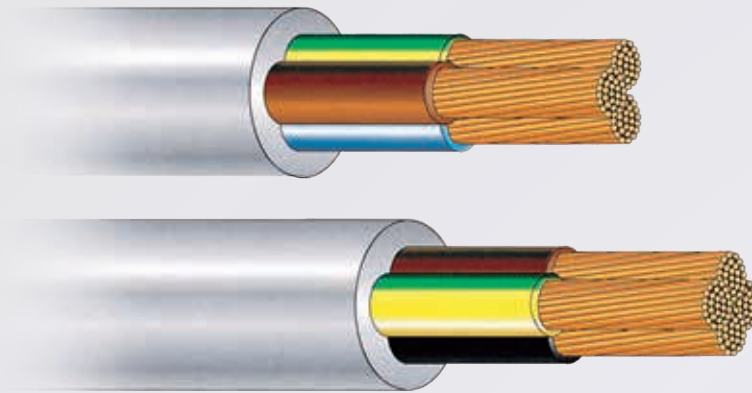

Nominal Cross Section	Numbers & diameter of Wires in Conductor	Approx. Diameter of Conductor	Nominal Thickness of Insulation	Nominal Thickness of Sheath	Approx. Overall Diameter	Weight of Finished Cable Approx.	Maximum Conductor DC Resistance at 20°C	Standard Packing Length
mm ²	no x mm	mm	mm	mm	mm	Kg / Km	Ohm / Km	M ± 5%
2 x 0.75	22 x 0.20	1.20	0.6	0.8	6.4	56	26.0	100
2 x 1	29 x 0.20	1.30	0.6	0.8	6.6	63	19.5	100
2 x 1.5	27 x 0.25	1.55	0.7	0.8	7.5	83	13.3	100
2 x 2.5	45 x 0.25	2.00	0.8	1.0	9.2	128	7.98	100
2 x 4	50 x 0.3	2.51	0.8	1.1	10.4	175	4.95	100
3 x 0.75	22 x 0.20	1.20	0.6	0.8	6.78	67	26.0	100
3 x 1	29 x 0.20	1.30	0.6	0.8	7.0	75	19.5	100
3 x 1.5	27 x 0.25	1.55	0.7	0.9	8.2	105	13.3	100
3 x 2.5	45 x 0.25	2.00	0.8	1.1	9.8	160	7.98	100
3 x 4	50 x 0.3	2.51	0.8	1.2	11.3	225	4.95	100
4 x 0.75	22 x 0.20	1.20	0.6	0.8	7.4	81	26.0	100
4 x 1	29 x 0.20	1.30	0.6	0.9	7.8	95	19.5	100
4 x 1.5	27 x 0.25	1.55	0.7	1.0	9.1	132	13.3	100
4 x 2.5	45 x 0.25	2.00	0.8	1.1	11.0	197	7.98	100
4 x 4	50 x 0.3	2.51	0.8	1.2	12.4	275	4.95	100
5 x 0.75	22 x 0.20	1.20	0.6	0.9	8.3	101	26.0	100
5 x 1	29 x 0.20	1.30	0.6	0.9	8.5	114	19.5	100
5 x 1.5	27 x 0.25	1.55	0.7	1.1	10.2	163	13.3	100
5 x 2.5	45 x 0.25	2.00	0.8	1.2	12.1	243	7.98	100
5 x 4	50 x 0.3	2.51	0.8	1.4	13.9	345	4.95	100

Colour of Insulation:

2 cores: blue, brown.

3 cores: green/yellow, blue, brown.

4 cores: green/yellow, blue, brown black.

5 cores: green/yellow, blue, brown, black, grey.

Colour of Outer sheath – White.



PVC INSULATION, NON-SHEATHED CORDS FOR INTERNAL WIRING

Single Core and Twisted Twin

COPPER CONDUCTOR: BS EN 50525-2-11 (BS 6500) and IEC 60227, 300 / 500 VOLTS H05V-K, TYPE 60227 IEC 06

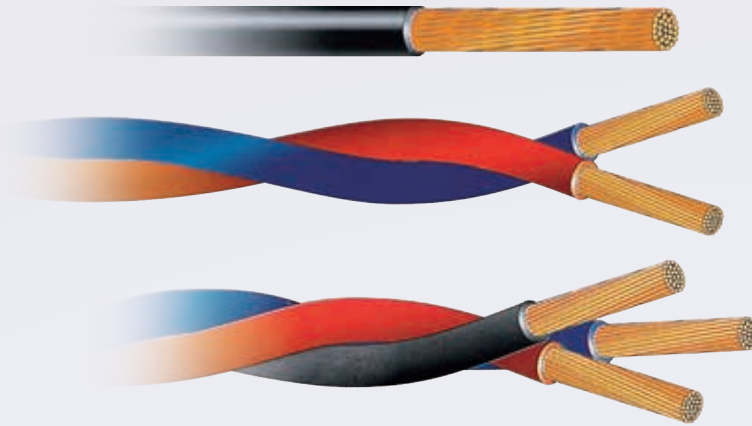

CONDUCTOR		Radial Thickness of insulation	Mean overall diameter (upper limit) single	Maximum Conductor DC Resistance at 20°C	Approximate Weight	
Nom. cross sectional area	Nom. diameter of strand				Single	Twin
mm ²	mm	mm	mm	Ω / Km	Kg / Km	Kg / Km
0.5	0.20	0.6	2.4	39.0	9	19
0.75	0.20	0.6	2.6	26.0	12	24
1.0	0.20	0.6	2.8	19.5	15	29

Construction:

- Annealed Copper conductor as per BS EN 60228 (BS 6360) or IEC 60228, Class 5 (Class 1 and Class 2 conductors can be provided based on special request)
- PVC Insulation Type T1 1

380 V NYFAF – PVC INSULATION, NON-SHEATHED FLEXIBLE CORDS FOR INTERNAL WIRING
Single, Three and Four

Nominal Cross Section	CONDUCTOR		Nominal Thickness of Insulation	Overall Dimension max	Maximum Conductor DC Resistance at 20°C	Approx. Weight of Finished Cable
	Max. Diameter of Wire in Conductor	Approx. Diameter of Conductor				
mm ²	mm	mm	mm	mm	Ω / Km	Kg / Km
1 x 0.50	0.21	0.9	0.6	2.4	37.1	9
1 x 0.75	0.21	1.1	0.6	2.6	24.7	12
3 x 0.50	0.21	0.9	0.6	5.2	39.0	27
3 x 0.75	0.21	1.1	0.6	5.6	26.0	36
4 x 0.50	0.21	0.9	0.6	5.8	39.0	36
4 x 0.75	0.21	1.1	0.6	6.2	26.0	48

Construction:

Annealed copper conductor
PVC Insulation.



PVC INSULATION, NON-SHEATHED FLEXIBLE CORDS FOR INTERNAL WIRING – PARALLEL TWIN
 COPPER CONDUCTOR
 H03VH-H 300/300 VOLTS - IEC 60227



CONDUCTOR		Radial Thickness of Insulation	Mean overall dimensions		Maximum Conductor DC Resistance at 20°C	Approx. Weight of Finished Cable
Nom. Cross Sectional area	Maximum diameter of Wire		Lower Limit	Upper Limit		
mm ²	mm	mm	mm	mm	Ω / Km	Kg / Km
2 x 0.50	0.16	0.8	2.4 x 4.9	3.0 x 5.9	39.0	22
2 x 0.75	0.16	0.8	2.6 x 5.2	3.1 x 6.3	26.0	28

Construction:

- Annealed Copper conductor as per BS EN 60228 (BS 6360) or IEC 60228 Class 6.
- The conductors shall be laid parallel and covered with PVC insulation.
- The insulation shall be provided with a groove on each side between the conductors to facilitate separation of the cores.



380 V NYIFY PVC INSULATION, PVC SHEATHED

Cables, Flat Twin, Three – Core: Four core and Five core



Nominal Cross Section	CONDUCTOR		Nominal Thickness of Insulation	Approx. Thickness of Sheath	Overall Dimension max	Maximum Conductor DC Resistance at 20°C	Approx. Weight of Finished Cable.
	Number of Wires in Conductor	Approx. Diameter of Conductor					
mm ²	mm	mm	mm	mm	mm	Ω / Km	Kg / Km
2 x 1.5	1	1.38	0.4	0.8	4.4 x 12.0	11.9	60
2 x 2.5	1	1.78	0.5	0.9	5.2 x 13.5	7.14	92
2 x 4	1	2.25	0.6	0.9	6.0 x 15.5	4.47	130
3 x 1.5	1	1.38	0.4	0.8	4.4 x 19.0	11.90	90
3 x 2.5	1	1.78	0.5	0.9	5.2 x 21.5	7.14	145
3 x 4	1	2.25	0.6	0.9	6.0 x 25.0	4.47	200
4 x 1.5	1	1.38	0.4	0.8	4.4 x 26.0	11.9	130
4 x 2.5	1	1.78	0.5	0.9	5.2 x 29.5	7.14	195
5 x 1.5	1	1.38	0.4	0.8	4.4 x 33.0	11.9	165
5 x 2.5	1	1.78	0.5	0.9	5.2 x 37.0	7.14	240

Construction:

Plain annealed copper conductor, PVC Insulated.

The insulated conductor shall be laid in parallel and covered with PVC sheath. The sheath shall be closely fitting but shall not adhere to the cores. The sheath shall be provided with a groove on each side between the cores to facilitate separation of the cores.



PVC INSULATED, PVC SHEATHED CABLES SINGLE CORE, FLAT TWIN AND FLAT THREE CORES WITHOUT EARTH CONTINUITY CONDUCTOR
COPPER CONDUCTOR – STANDARD: BS EN 50525-2-31 (BS 6004) – 300 / 500 VOLTS

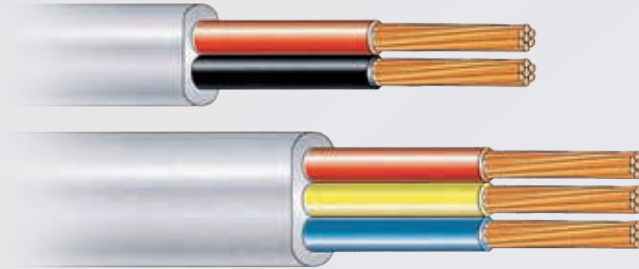

No. & Cross Sectional area of conductor	Number of Wires in Conductor	Radial Thickness of insulation	Radial Thickness of Sheath	Mean overall dimensions		Maximum Conductor DC Resistance at 20°C	Approx. Weight of Finished Cable
				Lower Limit	Upper Limit		
mm ²	mm	mm	mm	mm	mm	Ω / Km	Kg / Km
1 x 1.0	1	0.6	0.8	3.8	4.5	18.1	27
1 x 1.5	1	0.7	0.8	4.2	4.9	12.1	34
1 x 2.5	1	0.8	0.8	4.8	5.8	7.41	48
1 x 4	7	0.8	0.9	5.4	6.8	4.61	70
1 x 6	7	0.8	0.9	6.0	7.4	3.08	91
1 x 10	7	1.0	0.9	7.2	8.8	1.83	142
1 x 16	7	1.0	1.0	8.4	10.5	1.15	209
1 x 25	7	1.2	1.1	10.0	12.5	0.727	318
1 x 35	7	1.2	1.1	11.0	13.5	0.524	418
2 x 1.0	1	0.6	0.9	4.0 x 6.2	4.7 x 7.4	18.1	50
2 x 1.5	1	0.7	0.9	4.4 x 7.0	5.4 x 8.4	12.1	67
2 x 2.5	1	0.8	1.0	5.2 x 8.4	6.2 x 9.8	7.41	101
2 x 4	7	0.8	1.0	5.6 x 9.6	7.2 x 11.5	4.61	142
2 x 6	7	0.8	1.1	6.4 x 10.5	8.0 x 13.0	3.08	190
2 x 10	7	1.0	1.2	7.8 x 13.0	9.6 x 16.0	1.83	304
2 x 16	7	1.0	1.3	9.0 x 15.5	11.0 x 18.5	1.15	437
3 x 1.0	1	0.6	0.9	4.0 x 8.4	4.7 x 9.8	18.1	72
3 x 1.5	1	0.7	0.9	4.4 x 9.8	5.4 x 11.5	12.1	101
3 x 2.5	1	0.8	1.0	5.2 x 11.5	6.2 x 13.5	7.41	152
3 x 4	7	0.8	1.1	5.8 x 13.5	7.4 x 16.5	4.61	218
3 x 6	7	0.8	1.1	6.4 x 15.0	8.0 x 18.0	3.08	285
3 x 10	7	1.0	1.2	7.8 x 19.0	9.6 x 22.5	1.83	451
3 x 16	7	1.0	1.3	9.0 x 22.0	11.0 x 26.5	1.15	655

Construction:

Plain annealed copper conductor Class 1 or Class 2 as per BS EN 60228 (BS 6360).

- PVC Insulation Type TI 1
- PVC Sheath Type 6
- The sheath shall be closely fitting but shall not adhere to the cores and in the case of twin and three-core, the cores shall be laid parallel.

Colour of Insulation as per BS EN 50525-2-31 (BS 6004):

Single : Brown or Blue
Twin : Brown and Blue
Three-core: Brown, Black (center), Grey

Colour of Insulation General

Single : Black
Twin : Red, Black
Three-core: Red, Yellow, Blue

Color of Sheath: Grey



PVC INSULATION, PVC SHEATHED CABLES,

With Earth Continuity Conductor, Flat Twin and Flat Three Cores

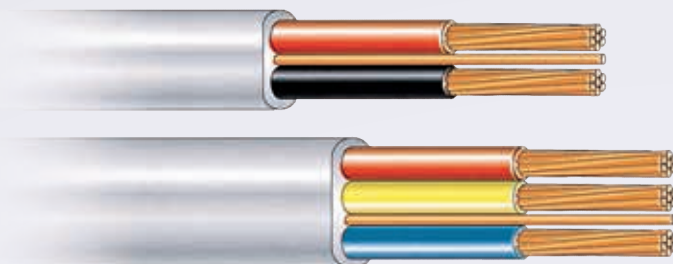

No. & Cross Sectional area of conductor	Number of Wires in Conductor	Radial Thickness of insulation	Radial Thickness of Sheath	Mean overall dimensions		Earth continuity conductor cross section	Maximum Conductor DC Resistance at 20°C	Approx. Weight of Finished Cable
				Lower Limit	Upper Limit			
mm ²	mm	mm	mm	mm	mm	mm ²	Ω / Km	Kg / Km
2 x 1.0	1	0.6	0.9	4.0 x 7.2	4.7 x 8.6	1.0	18.1	65
2 x 1.5	1	0.7	0.9	4.4 x 8.2	5.4 x 9.6	1.0	12.1	83
2 x 2.5	1	0.8	1.0	5.2 x 9.8	6.2 x 11.5	1.5	7.41	128
2 x 4	7	0.8	1.0	5.6 x 10.5	7.2 x 13.0	1.5	4.61	161
2 x 6	7	0.8	1.1	6.4 x 12.5	8.0 x 15.0	2.5	3.08	228
2 x 10	7	1.0	1.2	7.8 x 15.5	9.6 x 19.0	4	1.83	361
2 x 16	7	1.0	1.3	9.0 x 18.0	11.0 x 22.5	6	1.15	522
3 x 1.0	1	0.6	0.9	4.0 x 9.6	4.7 x 11.0	1.0	18.1	85
3 x 1.5	1	0.7	0.9	4.4 x 10.5	5.4 x 12.5	1.0	12.1	114
3 x 2.5	1	0.8	1.0	5.2 x 12.5	6.2 x 14.5	1.0	7.41	171
3 x 4	7	0.8	1.1	5.8 x 14.5	7.4 x 18.0	1.5	4.61	237
3 x 6	7	0.8	1.1	6.4 x 16.5	8.0 x 20.0	2.5	3.08	313
3 x 10	7	1.0	1.2	7.8 x 21.0	9.6 x 25.5	4	1.83	513
3 x 16	7	1.0	1.3	9.0 x 24.5	11.0 x 29.5	6	1.15	731

Construction:

Plain annealed copper conductor Class 1 or Class 2 as per BS EN 60228 (BS 6360).

- PVC Insulation Type TI 1
- PVC Sheath Type 6
- The sheath shall be closely fitting but shall not adhere to the cores which shall be laid parallel with un-insulated earth continuity conductor.

Colour of Insulation as per BS EN 50525-2-31 (BS 6004):

Single : Brown or Blue
 Twin : Brown and Blue
 Three-core: Brown, Black (center), Grey

Colour of Insulation General

Single : Black
 Twin : Red, Black
 Three-core: Red, Yellow, Blue

Color of Sheath: Grey



THHN, THWN, TFFN, WIRES

UL 83, UL 158

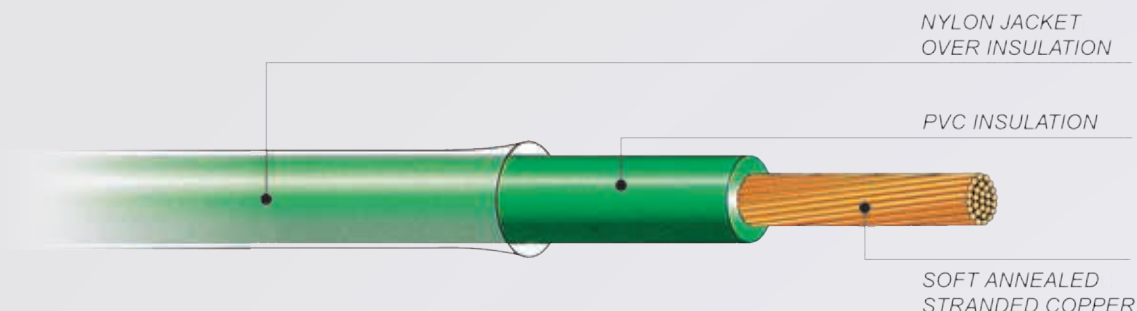

Construction:

- Conductor** - Soft drawn annealed copper conductors as per UL 83. Available in solid or stranded type for sizes 14, 12 and 10 AWG. Sizes 8 AWG and larger available in stranded only.
- Insulation** - Extruded Polyvinyl Chloride (PVC) compound rated 75 and 90°C.
- Jacket** - Tough, smooth, heat and light stabilized, low moisture absorption nylon conforming to UL requirements for type THHN or THWN. This jacket offers a great degree of protection to the PVC insulation from abrasion and cut through which may be encountered in pulling wire through conduits. Nylon has long been recognized as one of the toughest jacketing material used in wire and cable manufacturing.

Feature:

1. Meet UL "VW – 1' Flame Test requirements.
2. Wet or dry locations – Rated 90C dry, and 75°C wet.
3. Resistant to gas and oil exposure – Rated gasoline and oil resistant II per UL.
4. Versatile – Can be used as follows:
 - a) THHN - 90°C dry building wire
 - b) THWN - 75°C wet and dry building wire
 - c) MTW - 90°C machine tool wire
5. Pulls easier – tough, smooth nylon jacket over PVC insulation.
6. Small diameter – more conductors per conduit.

Applications:

Type THHN – THWN building wires are intended for general purpose applications and may be installed in conduit, duct or other recognized raceways in wet or dry locations. Type THHN – THWN wires are designed to operate at conductor temperatures of 75°C for 600 volts service in wet and dry location. Applicable for both new work and rewiring installations where the smaller wire diameter permits additional circuits or larger conductors to be installed in the conduit without exceeding fill limitations.

Type THHN – THWN wires are also recommended for industrial installation where exceptional resistance to heat and corrosive atmospheres are needed, such as chemical plants, oil refineries, paper mills, etc.



THHN, THWN, TFFN, WIRES

UL 83, UL 158

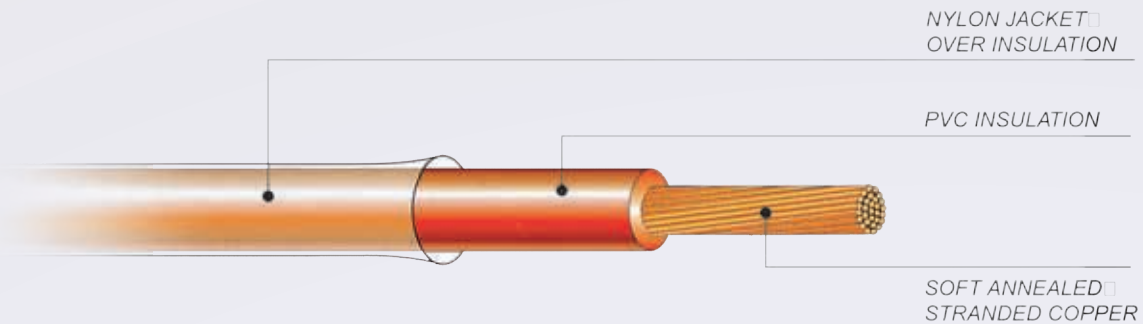

Markings:

The wire is surface marked as follows:

National Cables Industry, Year of manufacture, Typed THHN or THWN or TFFN Gasoline and Oil Resistant II, 600 Volts, VW – 1

Standards:

- UL 83 - Underwriters Laboratories, Thermoplastic Insulated wires and Cables.
- UL 1063 - Underwriters Laboratories, Machine Tool Wires and Cables.
- UL 1581 - Underwriters Laboratories, Reference standard for Electrical wires, Cables and Flexible Cords.

600 Volts

Copper Conductor PVC Insulated Nylon Jacketed THHN/THWN Wires UL 83, 1581

AWG	Equivalent	CONDUCTORS		Nominal Thickness of Insulation	Approx. Thickness of Nylon Jacket	Approx. Overall Diameter	Approx. Weight of Conductor	Standard DC Resistance at 20°C	Standard Packing Length
		No. of Stranding Wire	Approx. Diameter of Conductor						
	mm ²	No. x mm	mm	mm	mm	mm	Kg/Km	ohm/Km	M ± 5%
18*	0.82	16 x 0.254	1.19	0.38	0.10	2.3	12	18.23	152 C
16*	1.31	19 x 0.296	1.48	0.38	0.10	2.5	17	13.42	152 C
14	2.08	19 x 0.373	1.86	0.38	0.10	2.9	25	8.62	152 C
12	3.31	19 x 0.47	2.35	0.38	0.10	3.4	37	5.43	152 C
10	5.26	19 x 0.594	2.97	0.51	0.10	4.3	59	3.409	152 C
8	8.37	19 x 0.749	3.75	0.76	0.13	5.6	96	2.144	152 C
6	13.30	19 x 0.945	4.72	0.76	0.13	6.6	146	1.348	152 C
4	21.15	19 x 1.19	5.95	1.02	0.15	8.4	233	0.8481	1000C
2	33.63	19 x 1.50	7.50	1.02	0.15	9.9	356	0.5335	1000C
1/0	53.48	37 x 1.36	9.52	1.27	0.18	12.5	567	0.3354	1000C
2/0	67.43	37 x 1.52	10.64	1.27	0.18	13.6	697	0.266	1000C

*Listed as TFFN

Colour : Black, White, Red, Blue, Green, Yellow, Orange, Brown, etc.

Cutting Length: 152 M (500FT) in Coils 1000 M (3280 FT) in Drum



THHN, THWN, TFFN, WIRES

UL 83, UL 158

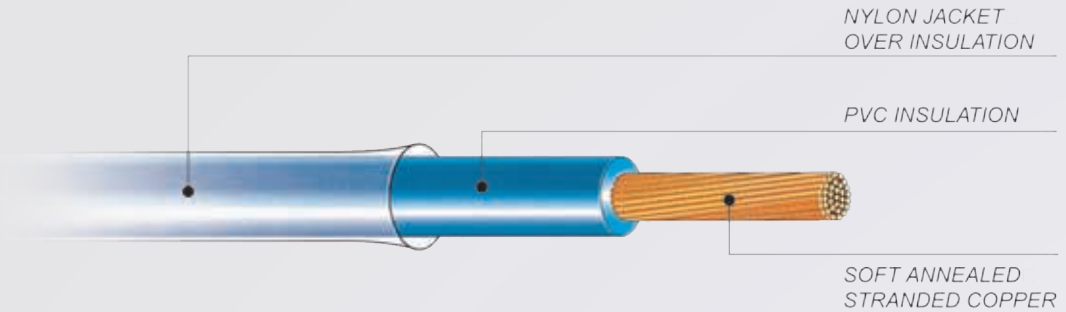

TABLE FOR THHN WIRE
TABLE 5

Size AWG	THWN AMPS	THHN AMPS
18		14
16		18
14	20	25
12	25	30
10	35	40
8	50	55
6	65	75
4	85	95
2	115	130
1/0	150	170
2/0	175	195

Current carrying capacities of THWN and THHN insulated Copper Conductors rated 600 V not more than three conductors in raceway or cable or earth (Direct Buried) base on ambient tempt. of 30° C.

TABLE 6

SIZE AWG	THWN AMPS	THHN AMPS
18		18
16		24
14	30	35
12	35	40
10	50	55
8	70	80
6	95	105
4	125	140
2	170	190
1/0	230	260
2/0	265	300

Current carrying capacities of THWN and THHN single insulated Copper Conductors rated 600 V in free air based on ambient air temperature of 30°C.

TABLE 7 –CORRECTION FACTORS

Ambient Temp. °C	THWN (75°C)	THHN (90°C)
21 - 25	1.05	1.04
26 - 30	1.00	1.00
31 - 35	0.94	0.96
36 - 40	0.88	0.91
41 - 45	0.82	0.87
46 - 50	0.75	0.82
51 -55	0.67	0.76
56 - 60	0.58	0.71
61 - 70	0.33	0.58
71 - 80		0.41

For ambient temperature other than 30°C multiply the ampacities given in table 5 & 6 by the appropriate factor given in Table 7.



THHN, THWN, TFFN, WIRES

UL 83, UL 158

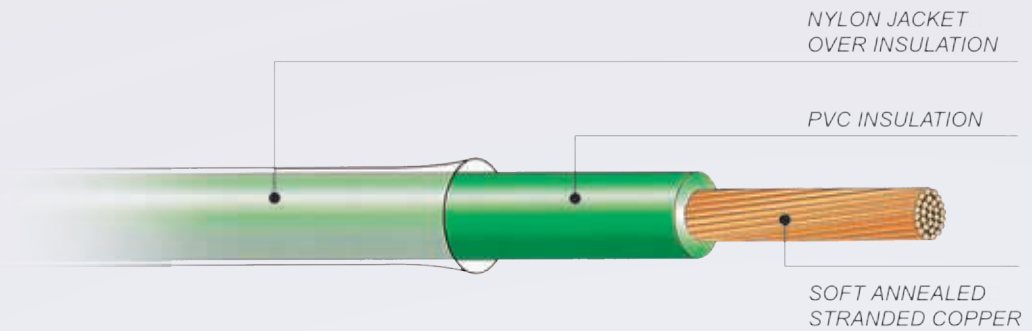

THHN/THWN BUILDING WIRE 90°C 600 VOLTS
TABLE 8 – Conduit Fill

Size AWG	Conduit Trade Size (inches)											
	1/2	3/4	1	1-1/4	1-1/2	2	2-1/2	3	3-1/2	4	5	6
18*	19	34	55	97	132	216	-	-	-	-	-	-
16*	15	26	43	76	104	169	-	-	-	-	-	-
14	13	24	39	69	94	154	-	-	-	-	-	-
12	10	18	29	51	70	114	164	-	-	-	-	-
10	6	11	18	32	44	73	104	160	-	-	-	-
8	3	5	9	16	22	36	51	79	106	136	-	-
6	1	4	6	11	15	26	37	57	76	98	154	-
4	1	2	4	7	9	16	22	35	47	60	94	137
3	1	1	3	6	8	13	19	29	39	51	80	116
2	1	1	3	5	7	11	16	25	33	43	67	97
1	-	1	1	3	5	8	12	18	25	32	50	72
1/0	-	1	1	3	4	7	10	15	21	27	42	61
2/0	-	1	1	2	3	6	8	13	17	22	35	51

Maximum number of THHN/THWN Conductors in conduit or tubing as per 1990 NEC

*Listed as TFFN

For groups or combinations of conductors, the conduit or tubing shall be of such size that the sum of the cross sectional areas of the individual conductors will not be more than percentage of the internal cross sectional area of the conduit or tubing as shown below.

TABLE 9 – Combination of Conductors

No. of Conductors	1	2	3	4	over 4
Percentage	53	31	40	40	40



Current Rating of CU/PVC Wires

TABLE 1

Current carrying capacity and associated voltage drop for single core PVC insulated cables, non-armoured, with or without sheath
CU/PVC 450 / 750 V Wires - BS EN 50525-2-31 (BS 6004) & BS 6231

Conductor operating temperature: 70°C Ambient temperature: 30°C

Conductor		Reference Method A (enclosed in conduit in the thermally insulating wall etc.)		Reference Method B (enclosed in conduit on a wall or in trunking etc.)		Reference method C (clipped direct)		Reference Method F (in free air or on a perforated cable tray horizontal or vertical)																						
		2 cables, single-phase a.c. or d.c.		3 or 4 cables three-phase a.c.		2 cables, single-phase a.c. or d.c.		3 or 4 cables three-phase a.c.		2 cables, single-phase a.c. or d.c. flat and touching		3 or 4 cables three-phase a.c. flat and touching or trefoil		Touching				Space by one diameter												
C.S.A.	Current carrying capacity	Voltage drop	Current carrying capacity	Voltage drop	Current carrying capacity	Voltage drop	Current carrying capacity	Voltage drop	Current carrying capacity	Voltage drop	Current carrying capacity	Voltage drop	Current carrying capacity	Voltage drop	Current carrying capacity	Voltage drop	Current carrying capacity	Voltage drop	Current carrying capacity	Voltage drop	2 cables, single-phase a.c. or d.c. flat		3 cables, three phase a.c. flat		3 cables, three phase a.c. trefoil		Horiz	Vert	2 cables, single phase a.c. or d.c. or 3 cables three phase a.c. flat	
																					Horiz	Vert	Single phase	Three phase						
1	2	3	4	5	6	7	8	9	10	11	12	13	14	15	16	17	18	19	20	21	22	23								
mm ²	A	A/m	A	mV/A/m	A	mV/A/m	A	mV/A/m	A	mV/A/m	A	mV/A/m	A	mV/A/m	A	mV/A/m	A	mV/A/m	A	A	A	mV/A/m	mV/A/m							
1.0	11	44	10.5	38	13.5	44	12	38	15.5	44	14	38	-	44	-	38	-	38	-	-	44	38								
1.5	14.5	29	13.5	25	17.5	29	15.5	25	20	29	18	25	-	29	-	25	-	25	-	-	29	25								
2.5	20	18	18	15	24	18	21	15	27	18	25	15	-	18	-	15	-	15	-	-	18	15								
4	26	11	24	9.5	32	11	28	9.5	37	11	33	9.5	-	11	-	9.5	-	9.5	-	-	11	9.5								
6	34	7.3	31	6.4	41	7.3	36	6.4	47	7.3	43	6.4	-	7.3	-	6.4	-	6.4	-	-	7.3	6.4								
10	46	4.4	42	3.8	57	4.4	50	3.8	65	4.4	59	3.8	-	4.4	-	3.8	-	3.8	-	-	4.4	3.8								
16	61	2.8	56	2.4	76	2.8	68	2.4	87	2.8	79	2.4	-	2.8	-	2.4	-	2.4	-	-	2.8	2.4								
25	80	1.80a	73	1.55	101	1.80	89	1.55	114	1.75	104	1.55	131	1.80	114	1.55	110	1.50	146	130	1.80	1.55								
35	99	1.30a	89	1.10	125	1.30	110	1.10	141	1.25	129	1.10	162	1.30	143	1.10	137	1.10	181	162	1.30	1.15								
50	119	1.00a	108	0.85	151	1.00	134	0.85	182	0.95	167	0.84	196	1.00	174	0.84	167	0.82	219	197	0.97	0.86								
70	151	0.72a	136	0.61	192	0.72	171	0.61	234	0.66	214	0.60	251	0.72	225	0.60	216	0.57	281	254	0.69	0.63								
95	182	0.56 a	164	0.48	232	0.56	207	0.48	284	0.50	261	0.47	304	0.56	275	0.47	264	0.43	341	311	0.54	0.51								
120	210	0.47a	188	0.41	269	0.47	239	0.41	330	0.41	303	0.40	352	0.47	321	0.40	308	0.36	396	362	0.45	0.44								
150	240	0.41a	216	0.36	300	0.41	262	0.36	381	0.34	349	0.34	406	0.41	372	0.34	356	0.30	456	419	0.39	0.40								
185	273	0.37a	245	0.32	341	0.37	296	0.32	436	0.29	400	0.31	463	0.37	427	0.31	409	0.26	521	480	0.35	0.36								
240	321	0.33a	286	0.29	400	0.33	346	0.29	515	0.25	472	0.27	546	0.33	507	0.27	485	0.22	615	569	0.31	0.34								
300	367	0.31a	328	0.27	458	0.31	394	0.27	594	0.22	545	0.25	629	0.31	587	0.25	561	0.190	709	659	0.29	0.32								
400	-	0.29a	-	0.25	546	0.29	467	0.25	694	0.20	634	0.24	754	0.29	689	0.24	656	0.175	852	795	0.27	0.31								
500	-	0.28a	-	0.25	626	0.28	533	0.25	792	0.185	723	0.23	868	0.28	789	0.23	749	0.160	982	920	0.26	0.30								
630	-	0.27a	-	0.24	720	0.27	611	0.24	904	0.175	826	0.22	1005	0.27	905	0.22	855	0.150	1138	1070	0.25	0.29								
800	-	-	-	-	-	-	-	-	1030	0.165	943	0.22	1086	-	1020	0.22	971	0.145	1265	1188	0.25	0.29								
1000	-	-	-	-	-	-	-	-	1154	0.160	1058	0.21	1216	-	1149	0.21	1079	0.140	1420	1337	0.24	0.28/								

Where more precise calculation requires the use of resistive and reactive components of cable impedance, reference should be made to Table 4D1A and 4D1B of BS 7671.

Notes:

- The current carrying capacities in columns 2 & 4 are also applicable to flexible cables to BS EN 50525-2-31 (BS 6004) (HO7V-K) where the cables are used in fixed installations.
- Spacing larger than one cable diameter will result in a larger voltage drop.
- Cables to BS 6231 when installed in conduit or trunking are rated for 70 °C

Correction Factors

For Ambient Temperature

Ambient Temperature 25°C 30°C 35°C 40°C 45°C 50°C 55°C 60°C
Correction Factor 1.03 1.0 0.94 0.87 0.79 0.71 0.61 0.50



Current Rating of CU/LSZH Wires

TABLE 2

Current carrying capacity and associated voltage drop for single core XLPE insulated cables, non-armoured, with or without sheath CU/LSZH 450 / 750 V Wires - BS EN 50525-3-41 (BS 7211)

Conductor operating temperature: 90°C Ambient temperature: 30°C

Conductor	Reference Method A (enclosed in conduit in thermally insulating wall etc.)				Reference Method B (enclosed in conduit on a wall or in trunking etc.)				Reference Method C (clipped direct)				Reference Method F (in free air or on a perforated cable tray horizontal or vertical)						Reference Method G (in free air)			
	2 cables, single-phase a.c. or d.c.		3 or 4 cables three- phase a.c.		2 cables, single-phase a.c. or d.c.		3 or 4 cables three- phase a.c.		2 cables, single-phase a.c. or d.c. flat and touching		3 or 4 cables three- phase a.c. flat and touching or trefoil		2 cables, single-phase a.c. or d.c. flat		3 cables, three phase a.c. flat		3 cables, three phase a.c. trefoil		Space by one diameter			
	Current carrying capacity	Voltage drop	Current carrying capacity	Voltage drop	Current carrying capacity	Voltage drop	Current carrying capacity	Voltage drop	Current carrying capacity	Voltage drop	Current carrying capacity	Voltage drop	Current carrying capacity	Voltage drop	Current carrying capacity	Voltage drop	Current carrying capacity	Voltage drop	Horiz	Vert	Single phase	Three phase
C.S.A.	Current carrying capacity	Voltage drop	Current carrying capacity	Voltage drop	Current carrying capacity	Voltage drop	Current carrying capacity	Voltage drop	Current carrying capacity	Voltage drop	Current carrying capacity	Voltage drop	Current carrying capacity	Voltage drop	Current carrying capacity	Voltage drop	Current carrying capacity	Voltage drop	Current carrying capacity	Current carrying capacity	Voltage drop	Voltage drop
1	2	3	4	5	6	7	8	9	10	11	12	13	14	15	16	17	18	19	20	21	22	23
mm ²	A	mV/A/m	A	mV/A/m	A	mV/A/m	A	mV/A/m	A	mV/A/m	A	mV/A/m	A	mV/A/m	A	mV/A/m	A	mV/A/m	A	A	mV/A/m	mV/A/m
1.0	14	46	13	40	17	46	15	40	19	46	17.5	40	-	46	-	40	-	40	-	-	46	40
1.5	19	31	17	27	23	31	20	27	25	31	23	27	-	31	-	27	-	27	-	-	31	27
2.5	26	19	23	16	31	19	28	16	34	19	31	16	-	19	-	16	-	16	-	-	19	16
4	35	12	31	10	42	12	37	10	46	12	41	10	-	12	-	10	-	10	-	-	12	10
6	45	7.9	40	6.8	54	7.9	48	6.8	59	7.9	54	6.8	-	7.9	-	6.8	-	6.8	-	-	7.9	6.8
10	61	4.7	54	4.0	75	4.7	66	4.0	81	4.7	74	4.0	-	4.7	-	4.0	-	4.0	-	-	4.7	4.0
16	81	2.9	73	2.5	100	2.9	88	2.5	109	2.9	99	2.5	-	2.9	-	2.5	-	2.5	-	-	2.9	2.5
25	106	1.90	95	1.65	133	1.90	117	1.65	143	1.85	130	1.60	135	1.85	141	1.60	135	1.60	182	161	1.85	1.65
35	131	1.35	117	1.15	164	1.35	144	1.15	176	1.35	161	1.15	169	1.35	176	1.15	169	1.15	226	201	1.35	1.20
50	158	1.05	141	0.90	198	1.05	175	0.90	228	1.00	209	0.87	207	1.00	216	0.87	207	0.87	275	246	1.00	0.89
70	200	0.75	179	0.65	253	0.75	222	0.65	293	0.71	268	0.61	246	0.71	279	0.62	268	0.61	353	318	0.73	0.65
95	241	0.58	216	0.50	306	0.58	269	0.50	355	0.52	326	0.45	328	0.52	342	0.46	328	0.45	430	389	0.56	0.49
120	278	0.48	249	0.42	354	0.48	312	0.42	413	0.43	379	0.37	383	0.43	400	0.38	383	0.37	500	454	0.47	0.42
150	318	0.43	285	0.37	393	0.43	342	0.37	476	0.36	436	0.31	444	0.36	464	0.32	444	0.31	577	527	0.41	0.37
185	362	0.37	324	0.32	449	0.37	384	0.32	545	0.30	500	0.26	510	0.30	533	0.28	510	0.26	661	605	0.36	0.33
240	424	0.33	380	0.29	528	0.33	450	0.29	644	0.25	590	0.22	607	0.25	634	0.24	607	0.22	781	719	0.31	0.29
300	486	0.31	435	0.27	603	0.31	514	0.27	743	0.22	681	0.195	703	0.22	736	0.21	703	0.195	902	833	0.29	0.27
400	-	0.29	-	0.25	683	0.29	584	0.25	868	0.20	793	0.175	823	0.20	868	0.195	823	0.175	1085	1008	0.27	0.26
500	-	0.28	-	0.24	783	0.28	666	0.24	990	0.185	904	0.160	946	0.185	998	0.180	946	0.160	1253	1169	0.26	0.25
630	-	0.27	-	0.23	900	0.27	764	0.23	1130	0.175	1033	0.150	1088	0.175	1151	0.170	1088	0.150	1454	1362	0.25	0.24
800	-	-	-	-	-	-	-	-	1288	0.170	1179	0.145	1214	0.170	1275	0.165	1214	0.145	1581	1485	0.25	0.24
1000	-	-	-	-	-	-	-	-	1443	0.165	1323	0.140	1349	0.165	1436	0.165	1349	0.140	1775	1671	0.24	0.24

Where more precise calculation requires the use of resistive and reactive components of cable impedance, reference should be made to Table 4E1A and 4E1B of BS 7671.

Notes:

- Where the conductor is to be protected by a semi-enclosed fuse to BS 3036, see item 5.1 of the preface to Appendix 4 of BS 7671
- Spacing larger than those specified in Method C (Table 4A) will result in a larger voltage drop.

Correction Factors For Ambient Temperature

Ambient Temperature	25°C	30°C	35°C	40°C	45°C	50°C	55°C	60°C	65°C	70°C	75°C	80°C
Correction Factor	1.03	1.0	0.94	0.87	0.79	0.71	0.61	0.50	0.65	0.58	0.50	0.41



Current Rating of CU/PVC/PVC 300/500 V Cables

TABLE 3

Current carrying capacity for Multicore PVC insulated, PVC sheathed, non-armoured cables as per BS EN 50525-2-31 (BS 6004)

Conductor operating temperature: 70°C Ambient temperature: 30°C For Installation required to comply with BS 7671

Conductor	Reference Method A (enclosed in conduit in the thermally insulating wall etc.)				Reference Method B (enclosed in conduit on a wall or in trunking etc.)				Reference method C (clipped direct)				Reference method F (in free air or on a perforated cable tray etc, horizontal or vertical)			
	1 two-core cable, single-phase a.c. or d.c.		1 three-core or 1 four-core cable, three-phase a.c.		1 two-core cable, single-phase a.c. or d.c.		1 three-core or 1 four-core cable, three-phase a.c.		1 two-core cable, single-phase a.c. or d.c.		1 three-core cable or 1 four-core cable, three-phase a.c.		1 two-core cable, single-phase a.c. or d.c.		1 three-core cable or 1 four-core cable, three phase a.c.	
C.S.A.	Current carrying capacity	Voltage drop	Current carrying capacity	Voltage drop	Current carrying capacity	Voltage drop	Current carrying capacity	Voltage drop	Current carrying capacity	Voltage drop	Current carrying capacity	Voltage drop	Current carrying capacity	Voltage drop	Current carrying capacity	Voltage drop
1	2	3	4	5	6	7	8	9	10	11	12	13	14	15	16	17
mm ²	A	mV/A/m	A	mV/A/m	A	mV/A/m	A	mV/A/m	A	mV/A/m	A	mV/A/m	A	mV/A/m	A	mV/A/m
1.0	11	44	10	38	13	44	11.5	38	15	44	13.5	38	17	44	14.5	38
1.5	14	29	13	25	16.5	29	15	25	19.5	29	17.5	25	22	29	18.5	25
2.5	18.5	18	17.5	15	23	18	20.	15	27	18	24	15	30	18	25	15
4	25	11	23	9.5	30	11	27	9.5	36	11	32	9.5	40	11	34	9.5
6	32	7.3	29	6.4	38	7.3	34	6.4	46	7.3	41	6.4	51	7.3	43	6.4
10	43	4.4	39	3.8	52	4.4	46	3.8	63	4.4	57	3.8	70	4.4	60	3.8
16	57	2.8	52	2.4	69	2.8	62	2.4	85	2.8	76	2.4	94	2.8	80	2.4
25	75	1.75	68	1.50	90	1.75	80	1.50	112	1.75	96	1.50	119	1.75	101	1.50
35	92	1.25	83	1.10	111	1.25	99	1.10	138	1.25	119	1.10	148	1.25	126	1.10
50	110	0.94	99	0.81	133	0.94	118	0.81	168	0.94	144	0.81	180	0.94	153	0.81
70	139	0.65	125	0.57	168	0.65	149	0.57	213	0.65	184	0.57	232	0.65	196	0.57
95	167	0.50	150	0.43	201	0.50	179	0.43	258	0.50	223	0.43	282	0.50	238	0.43
120	192	0.41	172	0.35	232	0.41	206	0.35	299	0.41	259	0.35	328	0.41	276	0.35
150	219	0.34	196	0.29	258	0.34	225	0.29	344	0.34	299	0.29	379	0.34	319	0.29
185	248	0.29	223	0.25	294	0.29	255	0.25	392	0.29	341	0.25	434	0.29	364	0.25
240	291	0.24	261	0.21	344	0.24	297	0.21	461	0.24	403	0.21	514	0.24	430	0.21
300	334	0.21	298	0.185	394	0.21	339	0.185	530	0.21	464	0.185	593	0.21	497	0.185
400	-	0.185	-	0.160	470	0.185	402	0.160	634	0.185	557	0.160	715	0.185	597	0.160

Where more precise calculation requires the use of resistive and reactive components of cable impedance, reference should be made to Table 4D2A and 4D2B of BS 7671.

**Correction Factors
For Ambient Temperature**

Ambient Temperature 25°C 30°C 35°C 40°C 45°C 50°C 55°C 60°C
 Correction Factor 1.03 1.0 0.94 0.87 0.79 0.71 0.61 0.50
 For grouping refer to Table 4C1 of BS 7671



Current Rating for Flat Cables

TABLE 4

Current carrying capacity and associated voltage drop for thermoplastic (PVC) insulated and Sheathed flat cable with protective earth continuity conductor for CU/PVC/PVC Cables

BS EN 50525-2-31 (BS 6004)

Conductor operating temperature: 70°C Ambient temperature: 30°C

For installation required to comply with BS 7671

Conductor	Reference method 100 (above a plasterboard ceiling covered by thermal insulation not exceeding 100mm in thickness)	Reference method 101 (above a plasterboard ceiling covered by thermal insulation not exceeding 100mm in thickness)	Reference method 102 (in a stud wall with thermal insulation with cable touching the inner surface wall)	Reference method 103 (in a stud wall with thermal insulation with cable not touching the inner surface wall)	Reference method C (slipped direct)	Reference method A (enclosed in conduit in an insulated wall)	Voltage drop
1	2	3	4	5	6	7	8
mm ²	A	A	A	A	A	A	mV/A/m
1	13	10.5	13	8	16	11.5	44
1.5	16	13	16	10	20	14.5	29
2.5	21	17	21	13.5	27	20	18
4	27	22	27	17.5	37	26	11
6	34	27	35	23.5	47	32	7.3
10	45	36	47	32	64	44	4.4
16	57	46	63	42.5	85	57	2.8

Notes:

Wherever practicable a cable is to be fixed in a position such that it will not be covered with thermal insulation, reference should be made to Table 4D5 of BS 7671

Correction Factors

For Alternative Ambient Temperatures

Ambient Temperature 25°C 30°C 35°C 40°C 45°C 50°C 55°C 60°C
 Correction Factor 1.03 1.0 0.94 0.87 0.79 0.71 0.61 0.50



Reference Methods as per BS 7671

The Reference Methods are those methods of installation for which the current-carrying capacity has been determined by test or calculation.

Reference Method A, for example, Installation Methods 1 and 2 (non-sheathed cables and multicore cables in conduit in a thermally insulated wall).

The wall consists of an outer weatherproof skin, thermal insulation and an inner skin of wood or wood-like material having a thermal conductance of at least $10 \text{ W/m}^2\text{K}$. The conduit is fixed such that it is close to, but not necessarily touching, the inner skin. Heat from the cables is assumed to escape through the inner skin only. The conduit can be metal or plastic.

Reference Method B, for example, Installation Method 4 of Table 2 (non-sheathed cables in conduit mounted on a wooden or masonry wall) and installation Method 5 (multicore cable in conduit on a wooden or masonry wall).

The conduit is mounted on a wooden wall such that the gap between the conduit and the surface is less than 0.3 times the conduit diameter. The conduit can be metal or plastic. Where the conduit is fixed to a masonry wall the current-carrying capacity of the non-sheathed or sheathed cable may be higher.

Reference Method C (clipped direct), for example, Installation Method 20 (single-core or multicore cable on a wooden or masonry wall)

Cable mounted on a wooden wall so that the gap between the cable and surface is less than 0.3 times the cable diameter. Where the cable is fixed to or embedded in a masonry wall the current-carrying capacity may be higher.

NOTE: The term “masonry” is taken to include brickwork, concrete, plaster and similar (but excluding thermally insulating materials)

Installation methods specifically for flat twin with earth continuity conductor cables in thermal insulation

Method 100 – Installation methods for flat twin and earth cable clipped direct to a wooden joist above a plasterboard ceiling with a minimum U value of $0.1 \text{ W/m}^2\text{K}$ and with thermal insulation no exceeding 100mm in thickness.

Method 101 - Installation methods for flat twin and earth cable clipped direct to a wooden joist above a plasterboard ceiling with a minimum U value of $0.1 \text{ W/m}^2\text{K}$ and with thermal insulation exceeding 100mm in thickness.

Method 102 - Installation methods for flat twin and earth cable in a stud wall with thermal insulation with a minimum U value of $0.1 \text{ W/m}^2\text{K}$ with the cable touching the inner wall surface.

Method 103 - Installation methods for flat twin and earth cable in a stud wall with thermal insulation with a minimum U value of $0.1 \text{ W/m}^2\text{K}$ with the cable not touching the inner wall surface.









Wherever practicable, a cable is to be fixed in a position such that it will not be covered with thermal insulation. Regulation 523.7, BS 5803-5: Appendix C: Avoidance of overheating of electric cables, Building Regulations Approved document B and Thermal insulation: avoiding risk. BR 262, BRE, 2001 refer.

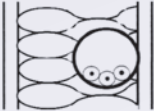
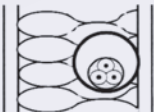

Table 4A2 – Schedule of Installation Methods of cables (including Reference Methods) for determining current-carrying capacity

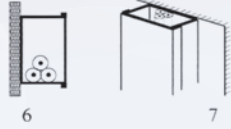
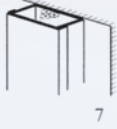
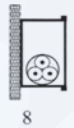
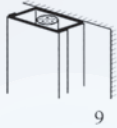
NOTE 1: The illustrations are not intended to depict actual product or installation practices but are indicative of the method described.

NOTE 2: The installation and reference methods stated are in line with IEC. However, not all methods have a corresponding rating for all cable types..

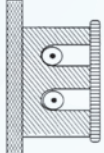
Number	Installation Method		Reference Method to be used to determine current-carrying capacity
	Examples	Description	
1	 Room	Non-sheathed cables in conduit in a thermally insulated wall with an inner skin having a thermal conductance of not less than 10 W/m ² K	A
2		Multicore cable in conduit in a thermally insulated wall with an inner skin having a thermal conductance of not less than 10 W/m ² K	A
3	 Room	Multicore cable direct in a thermally insulated wall with an inner skin having a thermal conductance of not less than 10 W/m ² K	A
4		Non-sheathed cables in conduit on a wooden or masonry wall or spaced less than 0.3 × conduit diameter from it ^c	B
5		Multicore cable in conduit on a wooden or masonry wall or spaced less than 0.3 × conduit diameter from it ^c	B
6 7	 6  7	Non-sheathed cables in cable trunking on a wooden or masonry wall 6 - run horizontally ^b 7 - run vertically ^{b,c}	B
8 9	 8  9	Multicore cable in cable trunking on a wooden or masonry wall 8 - run horizontally ^b 9 - run vertically ^{b,c}	B*
10		Non-sheathed cables in suspended cable trunking ^b	B
11	 10  11	Multicore cable in suspended cable trunking ^b	B
12		Non-sheathed cables run in mouldings ^{c,e}	A

^b Values given for Installation Method B in Appendix 4 are for a single circuit. Where there is more than one circuit in the trunking the group rating factor given in Table 4C1 is applicable, irrespective of the presence of an internal barrier or partition.

^c Care is needed where the cable runs vertically and ventilation is restricted. The ambient temperature at the top of the vertical section can be much higher.

^e The thermal resistivity of the enclosure is assumed to be poor because of the material of construction and possible air spaces. Where the construction is thermally equivalent to Installation Methods 6 or 7, Reference Method B may be used.

* Still under consideration in IEC.



Table 4A2 (continued)

Number	Installation Method		Reference Method to be used to determine current-carrying capacity
	Examples	Description	
13		Non-sheathed cables in skirting trunking	B
14		Multicore cable in skirting trunking	B
15		Non-sheathed cables in conduit or single-core or multicore cable in architrave ^{c, f}	A
16		Non-sheathed cables in conduit or single-core or multicore cable in window frames ^{c, f}	A
20		Single-core or multicore cables: - fixed on (clipped direct), or spaced less than 0.3 x cable diameter from a wooden or masonry wall ^c	C
21		Single-core or multicore cables: - fixed directly under a wooden or masonry ceiling	B (Higher than standard ambient temperatures may occur with this installation method)
22		Single-core or multicore cables: - spaced from a ceiling	E, F or G* (Higher than standard ambient temperatures may occur with this installation method)
23		Not used.	
30		Single-core or multicore cables: - on unperforated tray run horizontally or vertically ^{c, h}	C with item 2 of Table 4C1
31		Single-core or multicore cables: - on perforated tray run horizontally or vertically ^{c, h}	E or F
32		Single-core or multicore cables: - on brackets or on a wire mesh tray run horizontally or vertically ^{c, h}	E or F

^c Care is needed where the cable runs vertically and ventilation is restricted. The ambient temperature at the top of the vertical section can be much higher.

^f The thermal resistivity of the enclosure is assumed to be poor because of the material of construction and possible air spaces. Where the construction is thermally equivalent to Installation Methods 6, 7, 8, or 9, Reference Method B may be used.







^h D_e = the external diameter of a multicore cable:

- 2.2 x the cable diameter when three single-core cables are bound in trefoil, or
- 3 x the cable diameter when three single-core cables are laid in flat formation.

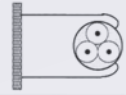
* Still under consideration in IEC.

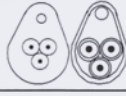

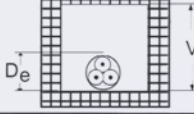
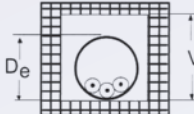
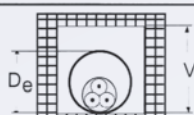
Table 4A2 (continued)

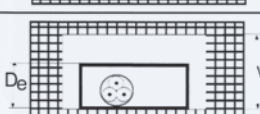
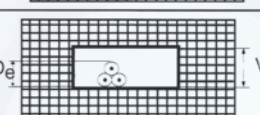
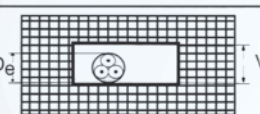
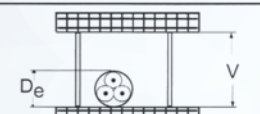
Installation Method			Reference Method to be used to determine current-carrying capacity
Number	Examples	Description	
33		Single-core or multicore cables: - spaced more than 0.3 times the cable diameter from a wall	E, F or G ^g
34		Single-core or multicore cables: - on a ladder ^c	E or F
35		Single-core or multicore cable suspended from or incorporating a support wire or harness	E or F
36		Bare or non-sheathed cables on insulators	G
40		Single-core or multicore cable in a building void ^{c, h, i}	Where $1.5 D_e \leq V < 20 D_e$ use B.
41		Non-sheathed cables in conduit in a building void in masonry having a thermal resistivity not greater than 2 K.m/W ^{c, i, j}	Where $1.5 D_e \leq V$ use B.
42		Single-core or multicore cable in conduit in a building void in masonry having a thermal resistivity not greater than 2 K.m/W ^{c, j}	Where $1.5 D_e \leq V$ use B.
43		Non-sheathed cables in cable ducting in a building void in masonry having a thermal resistivity not greater than 2 K.m/W ^{c, i, j}	Where $1.5 D_e \leq V$ use B.
44		Single-core or multicore cable in cable ducting in a building void in masonry having a thermal resistivity not greater than 2 K.m/W ^{c, i, j}	Where $1.5 D_e \leq V$ use B.
45		Non-sheathed cables in cable ducting in masonry having a thermal resistivity not greater than 2 K.m/W ^{c, h, i}	Where $1.5 D_e \leq V < 50 D_e$ use B.
46		Single-core or multicore cable in cable ducting in masonry having a thermal resistivity not greater than 2 K.m/W ^{c, h, i}	Where $1.5 D_e \leq V < 50 D_e$ use B.
47		Single-core or multicore cable: - in a ceiling void ^{h, i} - in a suspended floor ^{h, i}	Where $1.5 D_e \leq V < 50 D_e$ use B.

^c Care is needed where the cable runs vertically and ventilation is restricted. The ambient temperature at the top of the vertical section can be much higher.

^g The factors in Table 4C1 may also be used.





^h D_e = the external diameter of a multicore cable:
- $2.2 \times$ the cable diameter when three single-core cables are bound in trefoil, or
- $3 \times$ the cable diameter when three single-core cables are laid in flat formation.

ⁱ V = the smaller dimension or diameter of a masonry duct or void, or the vertical depth of a rectangular duct, floor or ceiling void or channel.

^j D_e = external diameter of conduit or vertical depth of cable ducting.

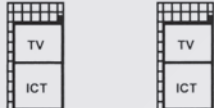
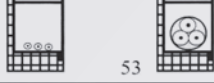

Table 4A2 (continued)

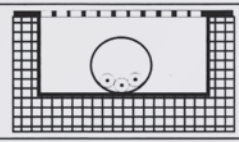
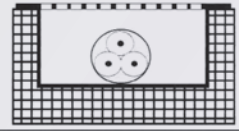
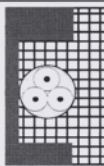
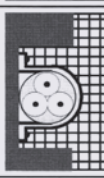
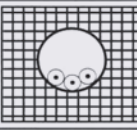
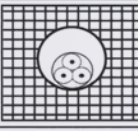
Number	Installation Method		Reference Method to be used to determine current-carrying capacity
	Examples	Description	
50		Non-sheathed cables in flush cable trunking in the floor	B
51		Multicore cable in flush cable trunking in the floor	B
52		Non-sheathed cables in flush trunking ^c	B
53		Multicore cable in flush trunking ^c	B
54		Non-sheathed cables or single-core cables in conduit in an unventilated cable channel run horizontally or vertically ^{c, i, k, m}	Where $1.5 D_e \leq V$ use B .
55		Non-sheathed cables in conduit in an open or ventilated cable channel in the floor ^{l, m}	B
56		Sheathed single-core or multicore cable in an open or ventilated cable channel run horizontally or vertically ^m	B
57		Single-core or multicore cable direct in masonry having a thermal resistivity not greater than 2 K.m/W - without added mechanical protection ^{n, o}	C
58		Single-core or multicore cable direct in masonry having a thermal resistivity not greater than 2 K.m/W - with added mechanical protection ^{n, o} (e.g. capping)	C
59		Non-sheathed cables or single-core cables in conduit in masonry having a thermal resistivity not greater than 2 K.m/W ^o	B
60		Multicore cables in conduit in masonry having a thermal resistivity not greater than 2 K.m/W ^o	B

^c Care is needed where the cable runs vertically and ventilation is restricted. The ambient temperature at the top of the vertical section can be much higher.

^k D_e = external diameter of conduit

ⁱ V = the smaller dimension or diameter of a masonry duct or void, or the vertical depth of a rectangular duct, floor or ceiling void or channel. The depth of the channel is more important than the width.

^l For multicore cable installed as Method 55, use current-carrying capacity for Reference Method B.

^m It is recommended that these Installation Methods are used only in areas where access is restricted to authorized persons so that the reduction in current-carrying capacity and the fire hazard due to the accumulation of debris can be prevented.

ⁿ For cables having conductors not greater than 16 mm², the current-carrying capacity may be higher.

^o Thermal resistivity of masonry is not greater than 2 K.m/W. The term masonry is taken to include brickwork, concrete, plaster and the like (excludes thermally insulating materials).





P.O. Box: 27472 Sharjah U.A.E.
Tel.: +971 6 5311888 (8 Lines) Fax.: +971 6 5311577
e-mail: n_c_i@emirates.net.ae website: www.nci.ae

NATIONAL
CABLES
INDUSTRY

NCI

الوطنية
لصناعة
الكابلات

Committed Quality for our Customers

LOW VOLTAGE CABLES

INNOVATIVE
PROCESSES AND
TECHNOLOGY STRATEGIES



INDEX

Introduction	03
Insulation and Sheathing Material Characteristics	05
Cables According to BS 6346	10
Cables According to BS 5467	13
Cables According to IEC 60502-1	16
Cables According to BS 6724	46
Electrical Parameters For LV Cables	49
Guidelines for the selection of the required size of cable.....	54
Drum Handling Instruction	55



INTRODUCTION

This catalog contains information on National Cables Industry low voltage cables with PVC and XLPE insulation, Copper/ Aluminium Conductors, Armoured and Un-armoured designs, single and multicore constructions along with a different range of sheathing options. Cables are categorized by insulation and armouring. Each section contains appropriate technical details and constructional data.

PRODUCT SPECIFICATION

All cable designs outlined in this catalog use constructions covered by IEC 60502, BS 6346, BS 5467 and BS 6724. National Cable Industry can also supply a range of alternative designs to meet more specialized customer needs including enhanced fire performance and added environmental protection. Cables can also be supplied with alternative sheathing materials and colors, or can be made to individual customer specifications or other recognized standards both National & International.

CABLE SELECTION

It is essential that the type of cable ordered is suitable for its intended use. Cable choice will be based on a whole range of factors including installation specifications, relevant local regulations and the performance of appropriate cable types. It is therefore impossible to provide a conclusive guide to cable selection and we would advice on suitable designs to meet your specific cable needs.

CONDUCTORS

Conductors shall be of Copper or Aluminium, circular stranded (Non-compacted or Compacted) or Shaped, Class 2 to IEC 60228, BS EN 60228. The number of wires for each conductor size mentioned in the tables is for standard construction. However, the minimum number of wires mentioned in IEC 60228/ BS EN 60228 shall hold precedence during manufacture. For smaller sizes, a solid circular conductor, Class 1 as per IEC 60228, BS EN 60228 can also be supplied upon request.

INSULATION

XLPE material and thickness shall be as per IEC 60502/BS 5467/BS 6724 rated for 90°C continues operation. PVC material and thickness shall be as per IEC 60502 or BS 6346. PVC insulation Material shall be Type A as per IEC 60502 or T11 as per BS 7655.

ASSEMBLY

For multicore cables, two, three or four insulated conductors are laid-up together with non-hygroscopic fillers compatible with the insulation material and the assembly is bedded with an extruded layer of PVC. In case of non-armoured cables, this layer may be omitted if the outer shape of the cable remains practically circular.

Standard COLOR CODE

Single Core	:	Red or Black
Two Cores	:	Red, Black
Three Cores	:	Red, Yellow, Blue
Four Cores	:	Red, Yellow, Blue, Black
Five Cores	:	Red, Yellow, Blue, Black, Green/ Yellow
Above Five Cores:		White numerals printed on black core insulation.

Cables with special colour code are also available based on special request.

Single Core	:	Brown or Blue
Two Cores	:	Brown, Blue
Three Cores	:	Green/Yellow, Blue, Brown
Four Cores	:	Blue, Brown, Black, Grey
Five Cores	:	Green/Yellow, Blue, Brown, Black, Grey
Above Five Cores:		Black Numerals printed on White core insulation.



INTRODUCTION

ARMOUR

Galvanized Steel Wires applied helically over bedding as per IEC 60502, BS 5467, BS 6346, BS 6724. (Single core cables shall be with Aluminium wire armour). Cables with Double steel tapes applied helically over the bedding of multi-core cables as per IEC 60502 are also available on request.

OUTER SHEATH

PVC type ST2 as per IEC 60502, Type 9 as per BS 7655 or LSZH Type ST8/LTS1 coloured Black. Low voltage cables can also be supplied with polyethylene outer sheath based on special request. Polyethylene offers the advantage of much greater impermeability to moisture compared to PVC and can also offer much greater abrasion resistance. These can be important factors when selecting cables for use in hostile environments.

All sheaths are designed with easy strip characteristics to reduce the time and cost of cable preparation during installation. In addition, finished cable are marked on the outer sheath to aid cable identification at site.

FIRE PERFORMANCE OF CABLE SHEATHS

Cables with special flame retardant PVC outer sheath to comply with the flame test requirements of IEC 60332-3-22, IEC 60332-3-23, IEC 60332-3-24 can also be supplied based on special request. Cables as per BS 6724 shall meet the requirements of low corrosive and low toxic gas emission as per BS 6724.

QUALITY

Effective Quality Management System is maintained at **NCI** as a key to long term operational reliability. Stringent quality control measures are implemented during procurement, during all stages of production and during final testing. Under professional control, NCI has demonstrated competence by obtaining Quality Management System **ISO-9001:2008** from **BASEC**, Product Certification Requirements from **BASEC** for “Enhanced Quality Management System for Product Related Functions”, Occupational Health and Safety Management System **OHSAS 18001:2007** from **SGS**, Emirates Mark of Conformity from **Emirates Authority for Standardization and Metrology (ESMA)**.

BASEC is a government-nominated independent non-profit making organization and a leader in product certification for more than 30 years and seeks to ensure National, European and International Manufacturers and their products in cable industry reach relevant standard.

SERVICES

National Cables Industry offers technical support for cable installation projects. Please contact our Customer Service Department for details.



PVC INSULATION

STANDARD: BS 7655, IEC 60502-1

PARTICULARS & GUARANTEES RELATING TO PVC INSULATING COMPOUND (TYPE T11)

SL NO.	DESCRIPTION	UNIT	GUARANTEED PARTICULARS
1	Tensile Strength and Elongation at break: Min. tensile strength Min. elongation at break	N/mm ² %	12.5 125
2	Low temperature bend test: Temperature at which specimen shall not crack	°C	-15 ± 2
3	Low temperature elongation test: Test temperature Min. Elongation	°C %	-15 ± 2 30
4	Low temperature impact test: Temperature at which specimen Shall not crack	°C	-15 ± 2
5	Accelerated ageing for specified Period at specified temperature Followed by loss of mass test: Max. loss of mass, after ageing for 7 days at 80 ± 2 °C	Mg/cm ²	2.0
6	Accelerated ageing for specified period at specified temperature Followed by tensile strength & Elongation at break Number of days ageing Ageing temperature Tensile Strength after ageing: Min. value Max. variation Elongation at break after ageing: Min. value Max. variation from unaged value	Days °C N/mm ² % % %	7 80 ± 2 12.5 20 125 20
7	Pressure test at high temperature: Test temperature Max. indention	°C %	80 ± 2 50
8	Resistance to cracking: Temperature at which specimen Shall not crack	°C	150 ± 2
9	Insulation resistance constant: Min. K. value at 70°C	M.Ω.km	0.037

PARTICULARS & GUARANTEES RELATING TO PVC INSULATING COMPOUND (TYPE A)

SL NO.	DESCRIPTION	UNIT	GUARANTEED PARTICULARS
1	Tensile Strength and Elongation at break: Min. tensile strength Min. elongation at break	N/mm ² %	12.5 150
2	Low temperature bend test: Temperature at which specimen shall not crack	°C	-15 ± 2
3	Low temperature elongation test: Test temperature Min. Elongation	°C %	-15 ± 2 20
4	Low temperature impact test: Test temperature Min. Elongation	°C	-
5	Accelerated ageing for specified Period at specified temperature Followed by loss of mass test: Max. loss of mass, after ageing for 7 days at 80 ± 2 °C	Mg/cm ²	-
6	Accelerated ageing for specified period at specified temperature Followed by tensile strength & Elongation at break Number of days ageing Ageing temperature Tensile Strength after ageing: Min. value Max. variation Elongation at break after ageing: Min. value Max. variation from unaged value	Days °C N/mm ² % % %	7 100 ± 2 12.5 25 150 25
7	Pressure test at high temperature: Test temperature Max. indention	°C %	80 ± 2 50
8	Resistance to cracking: Temperature at which specimen Shall not crack	°C	150 ± 2
9	Water Absorption Temperature Duration Max. variation of mass	°C Days mg/cm ²	70 ± 2 10 1



PVC INSULATION

STANDARD: BS 7655, IEC 60502-1

PARTICULARS & GUARANTEES RELATING TO PVC INSULATING COMPOUND (TYPE 5)

SL NO.	DESCRIPTION	UNIT	GUARANTEED PARTICULARS
1	Tensile Strength and Elongation at break: Min. tensile strength Min. elongation at break	N/mm ² %	12.5 125
2	Low temperature bend test: Temperature at which specimen shall not track	°C	-15 ± 2
3	Low temperature elongation test: Test temperature Min. Elongation	°C %	-15 ± 2 20
4	Accelerated ageing for specified at specified temperature followed by loss of mass test: Max. loss of mass, after ageing 10 days at 115 ± 2 °C	Mg/cm ²	1.5
5	Accelerated ageing for specified period at specified temperature Followed by tensile strength & Elongation at break Number of days ageing Ageing temperature Tensile Strength after ageing: Min. value Max. variation Elongation at break after ageing: Min. value Max. variation from unaged value	Days °C N/mm ² % % %	10 135 ± 2 12.5 25 125 25
6	Pressure test at high temperature: Test temperature Max. indentation	°C %	95 ± 2 50
7	Resistance to cracking: Temperature at which specimen Shall not crack	°C	150 ± 2
8	Insulation resistance constant: Min. K. value at 70°C	M.Ω.km	180

PARTICULARS & GUARANTEES RELATING TO XLPE INSULATION

SL NO.	DESCRIPTION	UNIT	GUARANTEED PARTICULARS
1	Tensile Strength and Elongation at break: Min. tensile strength Min. elongation at break	N/mm ² %	12.5 200
2	Accelerated ageing for specified period at specified temperature Followed by tensile strength & Elongation at break Number of days ageing Ageing temperature Max. variation of tensile strength From unaged specimen Max. variation of elongation from unaged specimen	Days °C % %	7 135 ± 2 ± 25 ± 25
3	Hot Set Test: Treatment: -Temperature -Time under load -Mechanical stress Max. elongation under load Max permanent elongation after Cooling	°C Minutes N/mm ² % %	200 ± 3 15 20 175 15
4	Water Absorption: Treatment: -Temperature -Duration Max. variation of mass	°C Days mg/cm ²	85 ± 2 14 1.0
5	Maximum permissible shrinkage: Treatment: -Temperature -Duration Maximum permissible shrinkage	°C Hours %	130 ± 2 1 4
6	Insulation Resistance constant (Ki) at maximum rated temperature (90 °C)	M.Ω.km	3.67
7	Volume Resistivity at maximum rated temperature (90 °C)	Ω.cm	10 ¹²



PVC OUTER SHEATH

STANDARD: IEC 60502-1, BS 7655

PARTICULARS & GUARANTEES RELATING TO PVC OUTER SHEATH TYPE ST2 (IEC 60502), TYPE 9 (BS 7655)

SL NO.	DESCRIPTION	UNIT	GUARANTEED PARTICULARS
1	Tensile Strength and Elongation at break: Min. tensile strength Min. elongation at break	N/mm ² %	12.5 150
2	Low temperature bend test: Temperature at which specimen shall not track	°C	-15 ± 2
3	Low temperature elongation test: Test temperature Min. Elongation	°C %	-15 ± 2 20
4	Low temperature impact test: Temperature at which specimen shall not crack	°C	-15 ± 2
5	Loss of mass: After ageing for 7 days at 100 ± 2 °C Max. loss of mass	mg/cm ²	1.5
6	Accelerated ageing for specified period at specified temperature Followed by tensile strength & Elongation at break test Number of days ageing Ageing temperature Tensile Strength after ageing: Min. value Max. variation Elongation at break after ageing: Min. value Max. variation from unaged value	Days °C N/mm ² % % %	7 100 ± 2 12.5 25 150 25
7	Pressure test at high temperature: Test temperature Max. indentation	°C %	90 ± 2 50
8	Heat Shock Test: Temperature at which specimen shall not crack	°C	150 ± 2
9	Insulation resistance constant: Min. K. value at 20°C	M.Ohm.km	0.0035
10	Flame Retardancy test (if required)	As per IEC 60332-1 (upon request)	



LSZH OUTER SHEATH

STANDARD: IEC 60502-1

600/1000 VOLTS

PARTICULARS & GUARANTEES RELATING TO LSZH OUTER SHEATH TYPE ST8 (IEC 60502-1)

SL NO.	DESCRIPTION	UNIT	GUARANTEED PARTICULARS
1	Tensile Strength and Elongation at break: Minimum Tensile Strength Minimum Elongation at break	N/mm ² %	9 125
2	Properties after ageing for specified period at specified temperature followed by tensile strength and elongation at break test. Number of days ageing Ageing temperature Tensile Strength after ageing: Minimum value Maximum variation Elongation at break after ageing: Minimum value Maximum variation from un-aged value	Days °C N/mm ² % % %	7 100 ± 2 9 40 100 40
3	Low temperature bend test: Test temperature at which specimen shall not crack	°C	-15 ± 2
4	Low temperature elongation test: Test temperature Minimum Elongation	°C %	-15 ± 2 20
5	Low temperature impact test: Temperature at which specimen shall not crack	°C	-15 ± 2
6	Pressure test at high temperature: Test temperature Maximum indentation	°C %	80 ± 2 50
7	Water Absorption: Ageing: Number of hours Ageing temperature Maximum increase in Mass	hours °C mg/cm ²	24 70 ± 2 10
8	Acidic emission and corrosive gases evolved Level of HCl Fluorine Content pH Minimum Conductivity	% % μS/mm	<0.5 <0.1 4.3 10



LSZH OUTER SHEATH

STANDARD: BS 6724, BS 7655

600/1000 VOLTS

PARTICULARS & GUARANTEES RELATING TO LSZH OUTER SHEATH TYPE LTS1 (BS 7655)

SL NO.	DESCRIPTION	UNIT	GUARANTEED PARTICULARS
1	Tensile Strength and Elongation at break: Minimum Tensile Strength Minimum Elongation at break	N/mm ² %	10 100
2	Properties after ageing for specified period at specified temperature followed by tensile strength and elongation at break test. Number of days ageing Ageing temperature Tensile Strength after ageing: Minimum value Maximum variation Elongation at break after ageing: Minimum value Maximum variation from un-aged value	Days °C N/mm ² % % %	7 100 ± 2 10 40 100 40
3	Low temperature bend test: Test temperature at which specimen shall not crack	°C	-15 ± 2
4	Low temperature elongation test: Test temperature Minimum Elongation	°C %	-15 ± 2 30
5	Low temperature impact test: Temperature at which specimen shall not crack	°C	-15 ± 2
6	Pressure test at high temperature: Test temperature Maximum indentation	°C %	80 ± 2 50
7	Tear Resistance Test as per BS 6469 (Sec. 99.1) Minimum value	N/mm	5
8	Water Immersion Test as per BS 6469 (Sec. 99.1) Ageing: Number of days Ageing temperature Maximum variation in tensile strength Maximum variation in elongation at break	Days °C % %	7 70 ± 2 30 30
9	Acidic emission and corrosive gases evolved Level of HCL	%	<0.5



PVC INSULATED, PVC SHEATHED CABLES

COPPER CONDUCTOR

STANDARD: BS 6346

0.6/1 kV



ALUMINIUM WIRE ARMoured CABLES

Nominal Area	No. of Wires	Approx. Conductor Diameter	Nominal Insulation Thickness	Nominal Alum/Steel Wire Dia.	Nominal Sheath Thickness	Approx. Overall Diameter	Approx. Weight	Standard Packing
mm ²	No.	mm	mm	mm	mm	mm	Kg/Km	meters
1x50 rmc	19	8.1	1.4	1.25	1.5	19	750	1000
1x70 rmc	19	9.7	1.4	1.25	1.6	21	1000	1000
1x95 rmc	19	11.4	1.6	1.25	1.6	23	1300	1000
1x120 rmc	37	12.9	1.6	1.6	1.7	26	1660	1000
1x150 rmc	37	14.3	1.8	1.6	1.7	28	1970	1000
1x185 rmc	37	16.0	2.0	1.6	1.8	30	2400	500
1x240 rmc	61	18.4	2.2	1.6	1.9	34	3025	500
1x300 rmc	61	20.4	2.4	1.6	1.9	37	3650	500
1x400 rmc	61	23.2	2.6	2.0	2.1	42	4675	500
1x500 rmc	61	26.7	2.8	2.0	2.1	46	5825	500
1x630 rmc	91	30.4	2.8	2.0	2.2	49	7275	500
1x800 rmc	91	33.7	2.8	2.5	2.4	56	9275	500
1x1000 rm	91	41.0	3.0	2.5	2.5	61	11800	250

STEEL WIRE ARMoured CABLES

2x1.5 rm	7	1.56	0.6	0.9	1.4	12.5	325	1000
2x2.5 rm	7	2.01	0.7	0.9	1.4	14	400	1000
2x4 rm	7	2.55	0.8	0.9	1.4	15	450	1000
2x6 rm	7	3.1	0.8	0.9	1.5	17	540	1000
2x10 rm	7	4.0	1.0	1.25	1.6	20	850	1000
2x16 rm	7	5.0	1.0	1.25	1.6	22	1070	1000
2x25 sm	7	-	1.2	1.6	1.7	23	1345	1000
2x35 sm	7	-	1.2	1.6	1.8	25	1615	1000
2x50 sm	19	-	1.4	1.6	1.9	28	2010	500
2x70 sm	19	-	1.4	1.6	1.9	30	2510	500
2x95 sm	19	-	1.6	2.0	2.1	35.5	3490	500
2x120 sm	37	-	1.6	2.0	2.2	38	4100	500
2x150 sm	37	-	1.8	2.0	2.3	41	4840	500
2x185 sm	37	-	2.0	2.5	2.4	46	6230	250
2x240 sm	61	-	2.2	2.5	2.5	51	7660	250
2x300 sm	61	-	2.4	2.5	2.7	56	9250	250

rm : Round Stranded
 rmc : Round Stranded Compacted
 sm : Sectoral Stranded

Standard Colour Code:

1 Core : Black (Red on request)
 2 Cores : Red, Black

Color Code based on special request.

1 Core : Brown or Blue
 2 Cores : Brown, Blue



PVC INSULATED, PVC SHEATHED CABLES

COPPER CONDUCTOR

STANDARD: BS 6346

0.6 /1 kV

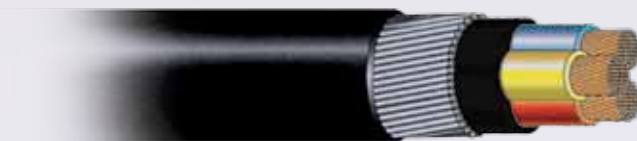

STEEL WIRE ARMoured CABLES

Nominal Area	No. of Wires	Approx. Conductor Diameter	Nominal Insulation Thickness	Nominal Steel Wire Dia.	Nominal Sheath Thickness	Approx. Overall Diameter	Approx. Weight	Standard Packing
mm ²	No.	mm	mm	mm	mm	mm	Kg/Km	meters
3x1.5 rm	7	1.56	0.6	0.9	1.4	13	320	1000
3x2.5 rm	7	2.01	0.7	0.9	1.4	14	400	1000
3x4 rm	7	2.55	0.8	0.9	1.4	16	500	1000
3x6 rm	7	3.12	0.8	1.25	1.5	18	720	1000
3x10 rm	7	4.01	1.0	1.25	1.6	21	960	1000
3x16 rm	7	5.03	1.0	1.25	1.6	23	1220	1000
3x25 sm	7	-	1.2	1.6	1.7	25	1720	1000
3x35 sm	7	-	1.2	1.6	1.8	27	2100	1000
3x50 sm	19	-	1.4	1.6	1.9	31	2665	1000
3x70 sm	19	-	1.4	2.0	2.0	35	3690	500
3x95 sm	19	-	1.6	2.0	2.1	39	4710	500
3x120 sm	37	-	1.6	2.0	2.2	42	5570	500
3x150 sm	37	-	1.8	2.5	2.4	48	7135	500
3x185 sm	37	-	2.0	2.5	2.5	52	8500	250
3x240 sm	61	-	2.2	2.5	2.6	58	10610	250
3x300 sm	61	-	2.4	2.5	2.8	64	12810	250
3x400 sm	61	-	2.6	2.5	3.0	70	15790	250

rm : Round Stranded
sm : Sectoral Stranded

Standard Colour Code:

3 core: Red, Yellow, Blue

Color Code based on special request.

3 Cores: Green / Yellow, Blue, Brown



PVC INSULATED, PVC SHEATHED CABLES

COPPER CONDUCTOR

STANDARD: BS 6346

0.6/1 kV



STEEL WIRE ARMoured CABLES

Nominal Area	No. of Wires	Approx. Conductor Diameter	Nominal Insulation Thickness	Nominal Steel Wire Diameter	Nominal Sheath Thickness	Approx. Overall Diameter	Approx. Weight	Standard Packing
mm ²	No.	mm	mm	mm	mm	mm	Kg/Km	meters
4x1.5 rm	7	1.56	0.6	0.9	1.4	13	360	1000
4x2.5 rm	7	2.01	0.7	0.9	1.4	14	460	1000
4x4 rm	7	2.55	0.8	1.25	1.5	17	700	1000
4x6 rm	7	3.12	0.8	1.25	1.5	19	830	1000
4x10 rm	7	4.01	1.0	1.25	1.6	22	1120	1000
4x16 rm	7	5.03	1.0	1.6	1.7	26	1700	1000
4x25 sm	7	-	1.2	1.6	1.8	28	2110	1000
4x35 sm	7	-	1.2	1.6	1.9	31	2590	1000
4x50 sm	19	-	1.4	2.0	2.0	36	3600	500
4x70 sm	19	-	1.4	2.0	2.1	40	4560	500
4x95 sm	19	-	1.6	2.0	2.2	44	5900	500
4x120sm	37	-	1.6	2.5	2.4	49	7500	500
4x150 sm	37	-	1.8	2.5	2.5	54	8900	250
4x185 sm	37	-	2.0	2.5	2.6	59	10770	250
4x240 sm	61	-	2.2	2.5	2.8	65	13490	250
4x300 sm	61	-	2.4	2.5	3.0	71	16320	250
4x400 sm	61	-	2.6	3.15	3.3	82	21250	250

STEEL WIRE ARMoured CABLES

5x1.5 rm	7	1.56	0.9	0.9	1.4	14	400	1000
5x2.5 rm	7	2.01	0.7	0.9	1.5	16	540	1000
5x4 rm	7	2.55	0.8	1.25	1.5	18	800	1000
5x6 rm	7	3.12	0.8	1.25	1.6	20	970	1000
5x10 rm	7	4.01	1.0	1.6	1.7	25	1510	1000
5x16 rm	7	5.03	1.0	1.6	1.7	28	1940	1000
5x25 rm	7	6.3	1.2	1.6	1.9	33	2690	500
5x35 rm	7	7.44	1.2	1.6	1.9	36	3320	500
5x50 rmc	19	8.10	1.4	2.0	2.1	41	4400	500
5x70 rmc	19	9.70	1.4	2.0	2.2	45	5670	500

rm : Round Stranded
 rmc : Round Stranded Compacted
 sm : Sectoral Stranded

Standard Colour Code:

4 cores: Red, Yellow, Blue, Black
 5 cores: Red, Yellow, Blue, Black, Green/Yellow

Color Code based on special request

4 cores: Blue, Brown, Black, Grey
 5 cores: Green/Yellow, Blue, Brown, Black, Grey



XLPE INSULATED, PVC SHEATHED CABLES

COPPER CONDUCTOR

STANDARD:BS 5467

0.6 /1 kV



ALUMINIUM WIRE ARMoured CABLES

Nominal Area	No. of Wires	Approx. Conductor Diameter	Nominal Insulation Thickness	Nominal Alum/Steel Wire Dia.	Nominal Sheath Thickness	Approx. Overall Diameter	Approx. Weight	Standard Packing
mm²	No.	mm	mm	mm	mm	mm	Kg/Km	meters
1x50 rmc	19	8.1	1.0	0.9	1.5	17	700	1000
1x70 rmc	19	9.7	1.1	1.25	1.5	20	925	1000
1x95 rmc	19	11.4	1.1	1.25	1.6	22	1200	1000
1x120 rmc	37	12.9	1.2	1.25	1.6	24	1450	1000
1x150 rmc	37	14.3	1.4	1.6	1.7	27	1850	1000
1x185 rmc	37	16.0	1.6	1.6	1.8	30	2250	1000
1x240 rmc	61	18.4	1.7	1.6	1.8	32	2850	500
1x300 rmc	61	20.4	1.8	1.6	1.9	35	3475	500
1x400 rmc	61	23.2	2.0	2.0	2.0	40	4470	500
1x500 rmc	61	26.7	2.2	2.0	2.1	44	5575	500
1x630 rmc	61	30.4	2.4	2.0	2.2	49	7050	500
1x800 rmc	61	33.7	2.6	2.5	2.4	55	9050	500
1x1000 rmc	91	41.0	2.8	2.5	2.5	60	11500	250

STEEL WIRE ARMoured CABLES

2x1.5 rm	7	1.56	0.6	0.9	1.3	12	280	1000
2x2.5 rm	7	2.01	0.7	0.9	1.4	14	350	1000
2x4 rm	7	2.55	0.7	0.9	1.4	15	425	1000
2x6 rm	7	3.12	0.7	0.9	1.4	16	500	1000
2x10 rm	7	4.01	0.7	0.9	1.5	18	655	1000
2x16 rm	7	5.03	0.7	1.25	1.5	20	970	1000
2x25 sm	7	-	0.9	1.25	1.6	24	1350	1000
2x35 sm	7	-	0.9	1.6	1.7	27	1850	1000

rm : Round Stranded
rmc : Round Stranded Compacted
sm : Sectoral Stranded

Standard Colour Code:

1 Core : Black (Red on request)
 2 Cores : Red, Black

Color Code based on special request

1 Core : Brown or Blue
 2 Cores : Brown, Blue



XLPE INSULATED, PVC SHEATHED CABLES

COPPER CONDUCTOR

STANDARD:BS 5467

0.6/1 kV



STEEL WIRE ARMoured CABLES

Nominal Area	No. of Wires	Approx. Conductor Diameter	Nominal Insulation Thickness	Nominal Steel Wire Dia.	Nominal Sheath Thickness	Approx. Overall Diameter	Approx. Weight	Standard Packing
mm ²	No.	mm	mm	Mm	mm	mm	Kg/Km	meters
3x1.5 rm	7	1.56	0.6	0.9	1.3	13	300	1000
3x2.5 rm	7	2.01	0.7	0.9	1.4	14	390	1000
3x4 rm	7	2.55	0.7	0.9	1.4	15	475	1000
3x6 rm	7	3.12	0.7	0.9	1.4	17	575	1000
3x10 rm	7	4.01	0.7	1.25	1.5	20	850	1000
3x16 rm	7	5.03	0.7	1.25	1.6	22	1110	1000
3x25 sm	7	-	0.9	1.6	1.7	24	1590	1000
3x35 sm	7	-	0.9	1.6	1.8	26	1965	1000
3x50 sm	19	-	1.0	1.6	1.8	29	2440	500
3x70 sm	19	-	1.1	1.6	1.9	32	3200	500
3x95 sm	19	-	1.1	2.0	2.1	37	4390	500
3x120 sm	37	-	1.2	2.0	2.2	41	5250	500
3x150 sm	37	-	1.4	2.5	2.3	46	6740	250
3x185 sm	37	-	1.6	2.5	2.4	50	8050	250
3x240 sm	61	-	1.7	2.5	2.6	55	9990	250
3x300 sm	61	-	1.8	2.5	2.7	60	12100	250
3x400 sm	61	-	2.0	2.5	2.9	67	14970	250

rm : Round Stranded
sm : Sectoral Stranded

Standard Colour Code:

3 cores : Red, Yellow, Blue

Color Code based on special request

3 cores : Green / Yellow, Blue, Brown



XLPE INSULATED, PVC SHEATHED CABLES

COPPER CONDUCTOR

STANDARD: BS 5467

0.6/1 kV

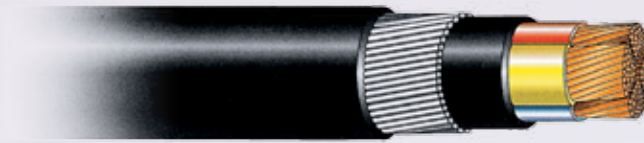

STEEL WIRE ARMoured CABLES

Nominal Area	No. of Wires	Approx. Conductor Diameter	Nominal Insulation Thickness	Nominal Steel Wire Diameter	Nominal Sheath Thickness	Approx. Overall Diameter	Approx. Weight	Standard Packing
mm ²	No.	mm	mm	mm	mm	mm	Kg/Km	meters
4x1.5 rm	7	1.56	0.6	0.9	1.3	13	350	1000
4x2.5 rm	7	2.01	0.7	0.9	1.4	15	450	1000
4x4 rm	7	2.55	0.7	0.9	1.4	16	550	1000
4x6 rm	7	3.12	0.7	1.25	1.5	19	775	1000
4x10 rm	7	4.01	0.7	1.25	1.5	21	1000	1000
4x16 rm	7	5.03	0.7	1.25	1.6	23	1325	1000
4x25 sm	7	-	0.9	1.6	1.7	26	1925	1000
4x35 sm	7	-	0.9	1.6	1.8	29	2390	1000
4x50 sm	19	-	1.0	1.6	1.9	32	3015	500
4x70 sm	19	-	1.1	2.0	2.1	38	4300	500
4x95 sm	19	-	1.1	2.0	2.2	42	5500	500
4x120sm	37	-	1.2	2.5	2.3	47	7035	500
4x150 sm	37	-	1.4	2.5	2.4	52	8410	500
4x185 sm	37	-	1.6	2.5	2.6	57	10150	250
4x240 sm	61	-	1.7	2.5	2.7	63	12750	250
4x300 sm	61	-	1.8	2.5	2.9	69	15440	250
4x400 sm	61	-	2.0	3.15	3.2	78	20210	250

STEEL WIRE ARMoured CABLES

5x1.5 rm	7	1.56	0.6	0.9	1.4	14	400	1000
5x2.5 rm	7	2.01	0.7	0.9	1.4	16	515	1000
5x4 rm	7	2.55	0.7	0.9	1.5	18	650	1000
5x6 rm	7	3.12	0.7	1.25	1.5	20	900	1000
5x10 rm	7	4.01	0.7	1.25	1.6	23	1190	1000
5x16 rm	7	5.03	0.7	1.6	1.7	27	1775	1000
5x25 rm	7	6.3	0.9	1.6	1.8	31	2450	1000
5x35 rm	7	7.44	0.9	1.6	1.9	35	3075	500
5x50 rmc	19	8.1	1.0	2.0	2.0	40	4040	500
5x70 rmc	19	9.7	1.1	2.0	2.2	46	5355	500

rm: Round Stranded
 rmc: Round Stranded Compacted
 sm: Sectoral Stranded

Standard Colour Code:

4 cores: Red, Yellow, Blue, Black
 5 cores: Red, Yellow, Blue, Black, Green/Yellow

Color Code based on special request

4 Cores: Blue, Brown, Black, Grey
 5 Cores: Green/Yellow, Blue, Brown, Black, Grey



PVC INSULATED, PVC SHEATHED CABLES

COPPER CONDUCTOR

STANDARD: IEC 60502-1

0.6/1 kV



CABLE CORE(S)

Nominal Area	No. of wires	Approx. conductor diameter	Nominal Insulation Thickness
mm ²	No.	mm	mm
1 x 1.5 re	1	1.38	0.8
1 x 1.5 rm	7	1.56	0.8
1 x 2.5 re	1	1.78	0.8
1 x 2.5 rm	7	2.01	0.8
1 x 4 re	1	2.25	1.0
1 x 4 rm	7	2.55	1.0
1 x 6 re	1	2.76	1.0
1 x 6 rm	7	3.12	1.0
1 x 10 re	7	3.57	1.0
1 x 10 rm	7	4.01	1.0
1 x 16 rm	7	5.03	1.0
1 x 25 rm	7	6.3	1.2
1 x 35 rm	7	7.44	1.2
1 x 50 rmc	19	8.1	1.4
1 x 70 rmc	19	9.7	1.4
1 x 95 rmc	19	11.4	1.6
1 x 120 rmc	37	12.9	1.6
1 x 150 rmc	37	14.3	1.8
1 x 185 rmc	37	16.0	2.0
1 x 240 rmc	61	18.4	2.2
1 x 300 rmc	61	20.4	2.4
1 x 400 rmc	61	23.2	2.6
1 x 500 rmc	61	26.7	2.8
1 x 630 rmc	61	30.4	2.8
1 x 800 rmc	61	33.7	2.8
1 x 1000 rm	91	41.0	3.0

UNARMoured

Nominal Sheath Thickness	Approx. Overall Diameter	Approx. Weight	Standard Packing
mm	no.	Kg/Km	meter
1.4	6	55	1000
1.4	6	55	1000
1.4	7	65	1000
1.4	7	70	1000
1.4	7	90	1000
1.4	8	95	1000
1.4	8	110	1000
1.4	8	120	1000
1.4	9	155	1000
1.4	9	165	1000
1.4	10	230	1000
1.4	12	335	1000
1.4	13	440	1000
1.4	14	550	1000
1.4	15	760	1000
1.5	18	1040	1000
1.5	19	1275	1000
1.6	21	1565	1000
1.7	24	1950	1000
1.7	27	2540	1000
1.8	29	3160	1000
1.9	33	4000	500
2.1	37	5070	500
2.2	40	6470	500
2.3	44	8150	250
2.5	52	10530	250

CABLE CORE(S)

2 x 1.5 re	1	1.38	0.8
2 x 1.5 rm	7	1.56	0.8
2 x 2.5 re	1	1.78	0.8
2 x 2.5 rm	7	2.01	0.8
2 x 4 re	1	2.25	1.0
2 x 4 rm	7	2.55	1.0
2 x 6 re	1	2.76	1.0
2 x 6 rm	7	3.12	1.0
2 x 10 re	1	3.57	1.0
2 x 10 rm	7	4.01	1.0
2 x 16 rm	7	5.03	1.0
2 x 25 sm	7	-	1.2
2 x 35 sm	7	-	1.2
2 x 50 sm	19	-	1.4
2 x 70 sm	19	-	1.4
2 x 95 sm	19	-	1.6
2 x 120 sm	37	-	1.6
2 x 150 sm	37	-	1.8
2 x 185 sm	37	-	2.0
2 x 240 sm	61	-	2.2
2 x 300 sm	61	-	2.4

UNARMoured

1.8	12	200	1000
1.8	12	200	1000
1.8	13	225	1000
1.8	13	250	1000
1.8	15	325	1000
1.8	15	325	1000
1.8	16	375	1000
1.8	16	400	1000
1.8	18	500	1000
1.8	18	525	1000
1.8	20	700	1000
1.8	21	790	1000
1.8	22	1000	1000
1.8	25	1300	1000
1.9	28	1735	1000
2.0	32	2350	500
2.1	34	2855	500
2.2	38	3480	500
2.4	41	4360	500
2.6	46	5600	250
2.7	57	6960	250

re : Round Solid
 rm : Round Stranded
 sm : Sectoral Stranded
 rmc : Round Stranded Compacted

Colour Code:
 1 Core: Black (red on request)
 2 Cores: Red, Black

Tolerance range:
 Overall diameter ± 5%
 Packing ± 5%



PVC INSULATED, PVC SHEATHED CABLES

COPPER CONDUCTOR

STANDARD: IEC 60502-1

0.6/1 kV



ALUMINIUM WIRE ARMoured

Nominal Alum./ Steel Wire diameter	Nominal Sheath Thickness	Approx. Overall diameter	Approx. Weight	Standard Packing
mm	mm	mm	Kg/Km	meters
-	-	-	-	-
0.8	1.8	11	150	-
-	-	-	-	-
0.8	1.8	12	175	-
-	-	-	-	-
0.8	1.8	13	200	-
-	-	-	-	-
0.8	1.8	13	250	-
-	-	-	-	-
0.8	1.8	14	300	1000
0.8	1.8	15	375	1000
0.8	1.8	17	500	1000
0.8	1.8	18	625	1000
1.25	1.8	20	800	1000
1.25	1.8	21	1025	1000
1.25	1.8	24	1325	1000
1.6	1.8	26	1650	1000
1.6	1.8	28	1950	1000
1.6	1.8	30	2375	500
1.6	1.9	33	3000	500
2.0	2.0	36	3750	500
2.0	2.1	40	4700	500
2.0	2.2	43	5850	500
2.0	2.4	48	7325	500
2.5	2.5	53	9300	250
2.5	2.7	61	11875	250

ALUMINIUM TAPE ARMoured

Aluminium / Steel Tape Thickness	Nominal Sheath Thickness	Approx. Overall diameter	Approx. Weight	Standard Packing
mm	mm	mm	Kg/Km	meters
-	-	-	-	-
-	-	-	-	-
-	-	-	-	-
-	-	-	-	-
-	-	-	-	-
-	-	-	-	-
-	-	-	-	-
-	-	-	-	-
-	-	-	-	-
0.5	1.8	14	300	1000
0.5	1.8	15	380	1000
0.5	1.8	17	500	1000
0.5	1.8	18	625	1000
0.5	1.8	19	775	1000
0.5	1.8	20	980	1000
0.5	1.8	22	1275	1000
0.5	1.8	23	1530	1000
0.5	1.8	26	1830	1000
0.5	1.8	28	2230	1000
0.5	1.9	30	2850	500
0.5	1.9	33	3480	500
0.5	2.1	37	4410	500
0.5	2.2	41	5550	500
0.5	2.3	45	6980	500
-	-	-	-	-
-	-	-	-	-

STEEL WIRE ARMoured

Nominal Alum./ Steel Wire diameter	Nominal Sheath Thickness	Approx. Overall diameter	Approx. Weight	Standard Packing
mm	mm	mm	Kg/Km	meters
-	-	-	-	-
-	1.8	14	350	1000
-	-	-	-	-
0.8	1.8	15	400	1000
0.8	1.8	17	515	1000
0.8	1.8	17	525	1000
0.8	1.8	19	730	1000
1.25	1.8	19	750	1000
1.25	1.8	20	825	1000
1.25	1.8	21	900	1000
1.25	1.8	23	1120	1000
1.6	1.8	24	1360	1000
1.6	1.8	26	1620	1000
1.6	1.9	28	2010	500
2.0	2.0	32	2740	500
2.0	2.2	36	3510	500
2.0	2.3	38	4120	500
2.5	2.4	43	5230	500
2.5	2.6	47	6280	250
2.5	2.8	52	7740	250
2.5	2.9	56	9310	250

STEEL TAPE ARMoured

Aluminium / Steel Tape Thickness	Nominal Sheath Thickness	Approx. Overall diameter	Approx. Weight	Standard Packing
mm	mm	mm	Kg/Km	meters
-	-	-	-	-
0.2	1.8	13	270	1000
-	-	-	-	-
0.2	1.8	14	320	1000
0.2	1.8	15	400	1000
0.2	1.8	16	420	1000
0.2	1.8	17	460	1000
0.2	1.8	17	500	1000
0.2	1.8	18	600	1000
0.2	1.8	19	640	1000
0.2	1.8	21	830	1000
0.2	1.8	22	910	1000
0.2	1.8	23	1130	1000
0.2	1.8	26	1440	1000
0.2	1.9	28	1900	1000
0.2	2.0	32	2540	500
0.5	2.2	36	3400	500
0.5	2.3	40	4080	500
0.5	2.4	43	4990	500
0.5	2.6	49	6310	250
0.5	2.8	53	7770	250



PVC INSULATED, PVC SHEATHED CABLES

COPPER CONDUCTOR

STANDARD: IEC 60502-1

0.6/1 kV



CABLE CORE(S)

Nominal Area	No. of Wires	Approx. Conductor Diameter	Nominal Insulation Thickness
mm ²	No.	mm	mm
3 x 1.5 re	1	1.38	0.8
3 x 1.5 rm	7	1.56	0.8
3 x 2.5 re	1	1.78	0.8
3 x 2.5 rm	7	2.01	0.8
3 x 4 re	1	2.25	1.0
3 x 4 rm	7	2.55	1.0
3 x 6 re	1	2.76	1.0
3 x 6 rm	7	3.12	1.0
3 x 10 re	1	3.57	1.0
3 x 10 rm	7	4.01	1.0
3 x 16 rm	7	5.03	1.0
3 x 25 sm	7	-	1.2
3 x 35 sm	7	-	1.2
3 x 50 sm	19	-	1.4
3 x 70 sm	19	-	1.4
3 x 95 sm	19	-	1.6
3 x 120 sm	37	-	1.6
3 x 150 sm	37	-	1.8
3 x 185 sm	37	-	2.0
3 x 240 sm	61	-	2.2
3 x 300 sm	61	-	2.4
3 x 400 sm	61	-	2.6
3 x 500 sm	61	-	2.8

UNARMoured

Nominal Sheath Thickness	Approx. Overall Diameter	Approx. Weight	Standard Packing
mm	mm	Kg/Km	meters
1.8	13	225	1000
1.8	13	240	1000
1.8	14	275	1000
1.8	14	300	1000
1.8	16	375	1000
1.8	16	400	1000
1.8	17	450	1000
1.8	17	485	1000
1.8	19	600	1000
1.8	19	590	1000
1.8	22	800	1000
1.8	23	1010	1000
1.8	25	1400	1000
1.8	28	1850	1000
2.0	32	2550	1000
2.1	36	3400	500
2.2	39	4160	500
2.3	43	5120	500
2.5	46	6340	500
2.7	53	8220	250
2.9	59	10170	250
3.1	67	12890	250
3.4	73	16290	250

re : Round Solid
 rm : Round Stranded
 sm : Sectoral Stranded

Colour Code:
 3 cores: Red, Yellow, Blue

Tolerance range:
 Overall diameter ±5%
 Packing ±5%



PVC INSULATED, PVC SHEATHED CABLES

COPPER CONDUCTOR

STANDARD:IEC 60502-1

0.6/1 kV



STEEL WIRE ARMoured

Steel Wire Diameter	Nominal Sheath Thickness	Approx. Overall diameter	Approx. Weight	Standard Packing
mm	mm	mm	Kg / Km	Meters
-	-	-	-	-
0.8	1.8	14	400	1000
-	-	-	-	-
0.8	1.8	15	470	1000
1.25	1.8	18	685	1000
1.25	1.8	18	740	1000
1.25	1.8	19	800	1000
1.25	1.8	19	850	1000
1.25	1.8	21	1000	1000
1.25	1.8	22	1000	1000
1.25	1.8	24	1270	1000
1.6	1.8	26	1740	1000
1.6	1.8	28	2110	1000
1.6	2.0	32	2680	500
2.0	2.1	38	3710	500
2.0	2.2	40	4730	500
2.0	2.3	43	5590	500
2.5	2.5	47	7160	500
2.5	2.7	53	8560	250
2.5	2.9	59	10700	250
2.5	3.1	65	12900	250
3.15	3.4	74	16820	250
3.15	3.6	80	20600	250

STEEL TAPE ARMoured

Steel Tape Thickness	Nominal Sheath Thickness	Approx. Overall diameter	Approx. Weight	Standard Packing
mm	mm	mm	Kg / Km	meters
-	-	-	-	-
0.2	1.8	14	300	1000
-	-	-	-	-
0.2	1.8	15	360	1000
0.2	1.8	17	450	1000
0.2	1.8	17	480	1000
0.2	1.8	18	500	1000
0.2	1.8	18	580	1000
0.2	1.8	19	700	1000
0.2	1.8	20	770	1000
0.2	1.8	22	930	1000
0.2	1.8	24	1230	1000
0.2	1.8	26	1550	1000
0.2	1.9	29	2030	1000
0.2	2.0	33	2740	500
0.5	2.2	38	3980	500
0.5	2.3	41	4780	500
0.5	2.4	46	5810	500
0.5	2.6	50	7010	500
0.5	2.8	56	9080	500
0.5	2.9	61	11080	500
0.5	3.2	69	13960	500
0.5	3.4	75	17420	500



PVC INSULATED, PVC SHEATHED CABLES

COPPER CONDUCTOR

STANDARD: IEC 60502-1

0.6/1 kV

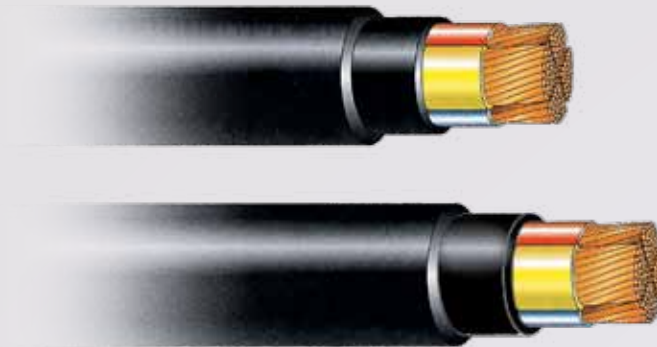

CABLE CORE (S)

Nominal Area	No. of Wires	Approx. Conductor diameter	Nominal Insulation Thickness
mm ²	No.	mm	mm
4 x 1.5 re	1	1.38	0.8
4 x 1.5 rm	7	1.56	0.8
4 x 2.5 re	1	1.78	0.8
4 x 2.5 rm	7	2.01	0.8
4 x 4 re	1	2.25	1.0
4 x 4 rm	7	2.55	1.0
4 x 6 re	1	2.76	1.0
4 x 6 rm	7	3.12	1.0
4 x 10 re	1	3.57	1.0
4 x 10 rm	7	4.01	1.0
4 x 16 rm	7	5.03	1.0
4 x 25 sm	7	-	1.2
4 x 35 sm	7	-	1.2
4 x 50 sm	19	-	1.4
4 x 70 sm	19	-	1.4
4 x 95 sm	19	-	1.6
4 x 120 sm	37	-	1.6
4 x 150 sm	37	-	1.8
4 x 185 sm	37	-	2.0
4 x 240 sm	61	-	2.2
4 x 300 sm	61	-	2.4
4 x 400 sm	61	-	2.6
4 x 500 sm	61	-	2.8

UNARMoured

Nominal Sheath Thickness	Approx. Overall diameter	Approx. Weight	Standard Packing
mm	mm	Kg/Km	meters
1.8	14	250	1000
1.8	14	275	1000
1.8	15	325	1000
1.8	15	335	1000
1.8	17	450	1000
1.8	17	460	1000
1.8	18	550	1000
1.8	18	575	1000
1.8	20	750	1000
1.8	21	730	1000
1.8	24	1010	1000
1.8	25	1390	1000
1.8	28	1800	1000
1.9	32	2410	1000
2.1	36	3300	500
2.2	41	4425	500
2.4	45	5440	500
2.5	49	6700	500
2.7	55	8350	250
2.9	61	10765	250
3.1	67	13360	250
3.4	76	17000	250
3.7	83	21460	250

re: Round Solid
rm: Round Stranded
sm: Sectoral Stranded

Colour Code :
4 Cores : Red, Yellow, Blue, Black

Tolerance range:
Overall diameter ±5%
Packing ±5%



PVC INSULATED, PVC SHEATHED CABLES

COPPER CONDUCTOR

STANDARD:IEC 60502-1

0.6/1 kV

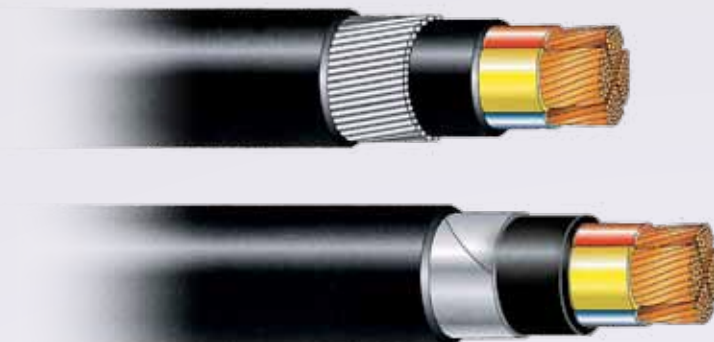

STEEL WIRE ARMoured

Steel Wire dia.	Nominal Sheath thickness	Approx. Overall diameter	Approx. Weight	Standard Packing
mm	mm	mm	Kg/Km	meters
-	-	-	-	-
0.8	1.8	15	450	1000
-	-	-	-	-
0.8	1.8	16	500	-
1.25	1.8	19	790	1000
1.25	1.8	20	825	1000
1.25	1.8	21	950	1000
1.25	1.8	21	975	1000
1.25	1.8	23	1175	1000
1.25	1.8	24	1175	1000
1.6	1.8	27	1675	1000
1.6	1.8	29	2110	1000
1.6	1.9	31	2590	1000
2.0	2.1	37	3615	500
2.0	2.2	40	4580	500
2.5	2.4	46	6340	500
2.5	2.5	50	7525	500
2.5	2.7	55	8950	500
2.5	2.9	60	10850	500
2.5	3.1	66	13580	250
3.15	3.3	73	17250	250
3.15	3.6	83	21375	250
3.15	3.9	90	26330	250

STEEL TAPE ARMoured

Steel Tape Thickness	Nominal Sheath Thickness	Approx. Overall diameter	Approx. Weight	Standard Packing
mm	mm	mm	Kg/Km	meters
-	-	-	-	-
0.2	1.8	14	330	1000
-	-	-	-	-
0.2	1.8	15	390	1000
0.2	1.8	18	525	1000
0.2	1.8	18	550	1000
0.2	1.8	19	640	1000
0.2	1.8	19	675	1000
0.2	1.8	21	850	1000
0.2	1.8	22	850	1000
0.2	1.8	24	1150	1000
0.2	1.8	26	1540	1000
0.2	1.8	29	1950	1000
0.2	2.0	33	2625	500
0.5	2.1	38	3850	500
0.5	2.3	43	5075	500
0.5	2.4	47	6150	500
0.5	2.6	52	7475	500
0.5	2.7	57	9200	500
0.5	3.0	63	11740	250
0.5	3.2	69	14425	250
0.5	3.5	78	18200	250
0.8	3.8	87	23590	250



PVC INSULATED, PVC SHEATHED CABLES

ALUMINIUM CONDUCTOR

STANDARD: IEC 60502-1

0.6/1 kV



CABLE CORE(S)

Nominal Area	No. of Wires	Approx. Conductor Diameter	Nominal Insulation Thickness
mm ²	no.	mm	mm
1 x 16 rm	7	5.2	1.0
1 x 25 rm	7	6.0	1.2
1 x 35 rm	7	7.41	1.2
1 x 50 rmc	7	8.30	1.4
1 x 70 rmc	19	9.70	1.4
1 x 95 rmc	19	11.55	1.6
1 x 120 rmc	19	12.95	1.6
1 x 150 rmc	19	14.30	1.8
1 x 185 rmc	37	15.9	2.0
1 x 240 rmc	37	18.4	2.2
1 x 300 rmc	37	20.5	2.4
1 x 400 rmc	61	24.0	2.6
1 x 500 rmc	61	27.0	2.8
1 x 630 rmc	61	30.4	2.8

CABLE CORE(S)

2 x 16 rm	7	5.2	1.0
2 x 25 rm	7	6.30	1.2
2 x 35 rm	7	7.41	1.2

CABLE CORE(S)

3 x 16 rm	7	5.2	1.0
3 x 25 rm	7	6.30	1.2
3 x 35 rm	7	7.41	1.2
3 x 50 rmc	7	8.30	1.4
3 x 70 rmc	19	9.7	1.4
3 x 95 rmc	19	11.5	1.6
3 x 120 rmc	19	12.95	1.6
3 x 150 rmc	19	14.30	1.8
3 x 185 rmc	37	15.9	2.0
3 x 240 rmc	37	18.4	2.2
3 x 300 rmc	37	20.5	2.4
3 x 400 rmc	61	24.0	2.6
3 x 500 rmc	61	27.0	2.8

rm: Round Stranded
rmc: Round Stranded Compacted

Colour Code:
1 Core: Black (Red on request)
2 Cores: Red, Black
3 Cores: Red, Yellow, Blue

Tolerance range:
Overall diameter ± 5%
Packing ± 5%

UNARMoured

Nominal Sheath Thickness	Approx. Overall Diameter	Approx. Weight	Standard Packing
mm	mm	Kg/Km	meters
1.4	10	140	1000
1.4	12	180	1000
1.4	13	230	1000
1.4	14	275	1000
1.4	16	350	1000
1.5	18	475	1000
1.5	20	550	1000
1.6	22	675	1000
1.7	24	825	1000
1.8	27	1060	1000
1.9	30	1300	1000
2.0	33	1650	500
2.1	37	2050	500
2.2	41	2540	500

UNARMoured

1.8	20	540	1000
1.8	23	725	1000
1.8	26	875	1000

UNARMoured

1.8	22	530	1000
1.8	25	720	1000
1.8	28	875	1000
1.8	30	1025	1000
2.0	34	1350	500
2.1	39	1775	500
2.2	43	2090	500
2.3	47	2550	500
2.5	51	3110	500
2.7	59	4050	250
2.9	65	4900	250
3.1	74	6250	250
3.4	82	7775	250



PVC INSULATED, PVC SHEATHED CABLES

ALUMINIUM CONDUCTOR

STANDARD:IEC 60502-1

0.6/1 kV



ALUMINIUM WIRE ARMoured

Nominal Alum / Steel Wire Diameter	Nominal Sheath Thickness	Approx. Overall diameter	Approx. Weight	Standard Packing
mm	mm	mm	Kg / Km	meters
0.8	1.8	15	300	1000
0.8	1.8	16	350	1000
0.8	1.8	17	410	1000
1.25	1.8	20	525	1000
1.25	1.8	21	625	1000
1.25	1.8	23	775	1000
1.6	1.8	25	925	1000
1.6	1.8	27	1060	1000
1.6	1.8	29	1240	1000
1.6	1.9	32	1530	500
2.0	2.0	36	1900	500
2.0	2.1	40	2375	500
2.0	2.2	44	2850	500
2.0	2.4	48	3425	500

ALUMINIUM TAPE ARMoured

Aluminium / Steel Tape Thickness	Nominal Sheath Thickness	Approx. Overall diameter	Approx. Weight	Standard Packing
mm	mm	mm	Kg/Km	meters
0.5	1.8	15	285	1000
0.5	1.8	17	360	1000
0.5	1.8	18	425	1000
0.5	1.8	20	480	1000
0.5	1.8	21	570	1000
0.5	1.8	24	710	1000
0.5	1.8	25	800	1000
0.5	1.8	27	950	1000
0.5	1.8	29	1100	1000
0.5	1.9	32	1380	500
0.5	1.9	35	1620	500
0.5	2.1	39	2070	500
0.5	2.2	43	2530	500
0.5	2.3	45	3050	500

STEEL WIRE ARMoured

1.25	1.8	24	980	1000
1.6	1.8	27	1400	1000
1.6	1.8	29	1610	1000

STEEL TAPE ARMoured

0.2	1.8	21	650	1000
0.2	1.8	24	860	1000
0.2	1.8	26	1030	1000

STEEL WIRE ARMoured

1.25	1.8	25	1000	1000
1.6	1.8	28	1420	1000
1.6	1.8	31	1650	1000
1.6	2.0	34	1930	500
2.0	2.1	39	2590	500
2.0	2.2	44	3200	500
2.0	2.3	47	3625	500
2.5	2.5	52	4725	500
2.5	2.7	57	5500	250
2.5	2.9	64	6775	250
2.5	3.1	70	7875	250
3.15	3.4	81	10600	250
3.15	3.6	88	12550	250

STEEL TAPE ARMoured

0.2	1.8	23	660	1000
0.2	1.8	26	860	1000
0.2	1.8	28	1025	1000
0.2	1.9	32	1225	1000
0.2	2.0	35	1550	500
0.5	2.2	41	2400	500
0.5	2.3	45	2770	500
0.5	2.4	49	3300	500
0.5	2.6	54	3940	500
0.5	2.8	61	4980	500
0.5	3.0	66	5900	500
0.5	3.2	76	7450	250
0.5	3.4	83	9050	250



PVC INSULATED, PVC SHEATHED CABLES

ALUMINIUM CONDUCTOR

STANDARD: IEC 60502-1

0.6 /1 kV



CABLE CORE(S)

Nominal Area	No. of Wires	Approx. Conductor diameter	Nominal Insulation Thickness
mm ²	No.	mm	mm
4 x 16 rm	7	5.2	1.0
4 x 25 rm	7	6.30	1.2
4 x 35 sm	7	-	1.2
4 x 50 sm	7	-	1.4
4 x 70 sm	19	-	1.4
4 x 95 sm	19	-	1.6
4 x 120 sm	19	-	1.6
4 x 150 sm	37	-	1.8
4 x 185 sm	37	-	2.0
4 x 240 sm	61	-	2.2
4 x 300 sm	61	-	2.4
4 x 400 sm	61	-	2.6
4 x 500 sm	61	-	2.8

UNARMoured

Nominal Sheath Thickness	Approx. Overall diameter	Approx. Weight	Standard Packing
mm	mm	Kg/Km	meters
1.8	24	640	1000
1.8	27	875	1000
1.8	28	950	1000
1.9	32	1260	500
2.1	36	1630	500
2.2	41	2110	500
2.3	45	2525	500
2.5	49	3075	500
2.7	55	3800	500
2.9	61	4825	250
3.1	67	5890	250
3.4	76	7475	250
3.7	83	9250	250

rm: Round Stranded
sm: Sectoral Stranded

Colour Code :
3½ Cores : Red, Yellow, Blue, Black
4 Cores: Red, Yellow, Blue, Black

Tolerance Range:
Overall diameter ±5%
Packing ±5%



PVC INSULATED, PVC SHEATHED CABLES

ALUMINIUM CONDUCTOR

STANDARD:IE 60502-1

0.6/1 kV

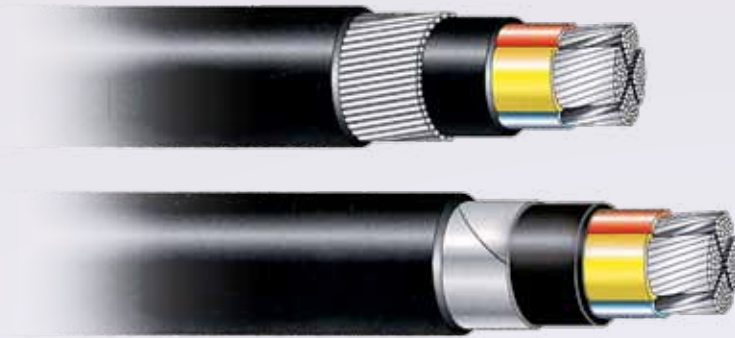

STEEL WIRE ARMoured

Steel Wire Diameter	Nominal Sheath Thickness	Approx. Overall diameter	Approx. Weight	Standard Packing
mm	mm	mm	Kg / Km	meters
1.6	1.8	27	1310	1000
1.6	1.8	31	1640	1000
1.6	1.9	31	1750	500
2.0	2.1	37	2470	500
2.0	2.2	40	2930	500
2.5	2.4	46	4025	500
2.5	2.5	50	4600	500
2.5	2.7	55	5325	500
2.5	2.9	60	6320	250
2.5	3.1	66	7650	250
3.15	3.3	73	9790	250
3.15	3.6	83	11850	250
3.15	3.9	90	14100	250

STEEL TAPE ARMoured

Steel Tape Thickness	Nominal Sheath Thickness	Approx. Overall diameter	Approx. Weight	Standard Packing
mm	mm	mm	Kg/Km	meters
0.2	1.8	25	775	1000
0.2	1.8	28	1030	1000
0.2	1.8	29	1110	1000
0.2	2.0	33	1475	500
0.5	2.1	38	2175	500
0.5	2.3	43	2760	500
0.5	2.4	47	3230	500
0.5	2.6	51	3850	500
0.5	2.7	57	4650	500
0.5	3.0	63	5800	250
0.5	3.2	69	6950	250
0.5	3.5	78	8675	250
0.8	3.8	87	11380	250



XLPE INSULATED, PVC SHEATHED CABLES

COPPER CONDUCTORS

STANDARD: IEC 60502-1

0.6/1 kV



CABLE CORE(S)

Nominal Area	No. of wires	Approx. conductor diameter	Nominal Insulation Thickness
mm ²	No.	mm	mm
1 x 1.5 re	1	1.38	0.7
1 x 1.5 rm	7	1.56	0.7
1 x 2.5 re	1	1.78	0.7
1 x 2.5 rm	7	2.01	0.7
1 x 4 re	1	2.25	0.7
1 x 4 rm	7	2.55	0.7
1 x 6 re	1	2.76	0.7
1 x 6 rm	7	3.12	0.7
1 x 10 rm	7	4.01	0.7
1 x 16 rm	7	5.03	0.7
1 x 25 rm	7	6.3	0.9
1 x 35 rm	7	7.44	0.9
1 x 50 rmc	19	8.1	1.0
1 x 70 rmc	19	9.7	1.1
1 x 95 rmc	19	11.4	1.1
1 x 120 rmc	37	12.9	1.2
1 x 150 rmc	37	14.3	1.4
1 x 185 rmc	37	16.0	1.6
1 x 240 rmc	61	18.4	1.7
1 x 300 rm	61	20.4	1.8
1 x 400 rmc	61	23.2	2.0
1 x 500 rmc	61	26.7	2.2
1 x 630 rmc	61	30.4	2.4
1 x 800 rmc	61	33.7	2.6
1 x 1000 rm	91	41.0	2.8

UNARMoured

Nominal Sheath Thickness	Approx. Overall Diameter	Approx. Weight	Standard Packing
mm	mm	Kg/Km	meters
1.4	6	45	1000
1.4	6	50	1000
1.4	6	60	1000
1.4	7	60	1000
1.4	7	75	1000
1.4	7	80	1000
1.4	7	95	1000
1.4	8	100	1000
1.4	9	145	1000
1.4	10	200	1000
1.4	11	300	1000
1.4	12	400	1000
1.4	13	515	1000
1.4	15	720	1000
1.5	17	975	1000
1.5	19	1210	1000
1.6	21	1490	1000
1.6	23	1850	1000
1.7	25	2400	1000
1.8	28	3000	1000
1.9	31	3800	500
2.0	35	4850	500
2.2	40	6250	500
2.3	44	7950	500
2.4	51	10180	250

CABLE CORE(S)

2 x 1.5 re	1	1.38	0.7
2 x 1.5 rm	7	1.56	0.7
2 x 2.5 re	1	1.78	0.7
2 x 2.5 rm	7	2.01	0.7
2 x 4 re	1	2.25	0.7
2 x 4 rm	7	2.55	0.7
2 x 6 re	1	2.76	0.7
2 x 6 rm	7	3.12	0.7
2 x 10 rm	7	4.01	0.7
2 x 16 rm	7	5.03	0.7
2 x 25 sm	7	-	0.9
2 x 35 sm	7	-	0.9

UNARMoured

1.8	12	175	1000
1.8	12	200	1000
1.8	13	225	1000
1.8	13	225	1000
1.8	14	275	1000
1.8	14	270	1000
1.8	15	325	1000
1.8	15	340	1000
1.8	17	455	1000
1.8	19	620	1000
1.8	19	715	1000
1.8	21	915	1000

re: Round Solid
rm: Round Stranded
rmc: Round Stranded Compacted

Colour Code:
1 Core: Black (red on request)
2 Cores: Red, Black

Tolerance range:
Overall diameter ± 5%
Packing ± 5%



XLPE INSULATED, PVC SHEATHED CABLES

COPPER CONDUCTOR

STANDARD: IEC 60502-1

0.6/1 kV



ALUMINIUM WIRE ARMoured

Nominal Alum./ Steel Wire Diameter	Nominal Sheath Thickness	Approx. Overall diameter	Approx. Weight	Standard Packing
mm	mm	mm	Kg/Km	meters
-	-	-	-	-
0.8	1.8	10	150	-
-	-	-	-	-
0.8	1.8	11	150	-
-	-	-	-	-
0.8	1.8	11	175	-
-	-	-	-	-
0.8	1.8	12	225	-
0.8	1.8	13	275	-
0.8	1.8	16	435	-
0.8	1.8	17	570	1000
0.8	1.8	18	680	1000
1.25	1.8	19	820	1000
1.25	1.8	21	1055	1000
1.25	1.8	22	1330	1000
1.6	1.8	24	1600	1000
1.6	1.8	26	1900	1000
1.6	1.8	28	2300	1000
1.6	1.9	31	2900	500
1.6	2.0	33	3540	500
2.0	2.1	38	3540	500
2.0	2.2	42	5635	500
2.0	2.3	46	7100	500
2.5	2.5	52	9120	250
2.5	2.7	60	11290	250

ALUMINIUM TAPE ARMoured

Aluminium/ Steel Tape Thickness	Nominal Sheath Thickness	Approx. Overall diameter	Approx. Weight	Standard Packing
mm	mm	mm	Kg/Km	meters
-	-	-	-	-
-	-	-	-	-
-	-	-	-	-
-	-	-	-	-
-	-	-	-	-
-	-	-	-	-
-	-	-	-	-
-	-	-	-	-
-	-	-	-	-
0.5	1.8	16	460	1000
0.5	1.8	17	570	1000
0.5	1.8	18	700	1000
0.5	1.8	20	930	1000
0.5	1.8	21	1220	1000
0.5	1.8	23	1460	1000
0.5	1.8	25	1750	1000
0.5	1.8	27	2130	1000
0.5	1.8	29	2700	500
0.5	1.9	32	3320	500
0.5	2.0	36	4210	500
0.5	2.1	40	5310	500
0.5	2.3	44	6760	500
-	-	-	-	-
-	-	-	-	-

STEEL WIRE ARMoured

-	-	-	-	-
0.8	1.8	14	325	1000
-	-	-	-	-
0.8	1.8	15	380	1000
0.8	1.8	15	450	1000
0.8	1.8	16	450	1000
0.8	1.8	16	525	1000
0.8	1.8	17	530	1000
1.25	1.8	19	810	1000
1.25	1.8	21	1020	1000
1.6	1.8	25	1525	1000
1.6	1.8	28	1850	1000

STEEL TAPE ARMoured

-	-	-	-	-
0.2	1.8	13	250	1000
-	-	-	-	-
0.2	1.8	13	300	1000
0.2	1.8	15	350	1000
0.2	1.8	15	350	1000
0.2	1.8	16	400	1000
0.2	1.8	16	440	1000
0.2	1.8	18	570	1000
0.2	1.8	20	750	1000
0.2	1.8	20	830	1000
0.2	1.8	22	1040	1000



XLPE INSULATED, PVC SHEATHED CABLES

COPPER CONDUCTOR

STANDARD:IEC 60502-1

0.6/1 kV



CABLE CORE(S)

UNARMoured

Nominal Area	No. of Wires	Approx. Conductor diameter	Nominal Insulation Thickness
mm ²	No.	mm	mm
3 x 1.5 re	1	1.38	0.7
3 x 1.5 rm	7	1.56	0.7
3 x 2.5 re	1	1.78	0.7
3 x 2.5 rm	7	2.01	0.7
3 x 4 re	1	2.25	0.7
3 x 4 rm	7	2.55	0.7
3 x 6 re	1	2.76	0.7
3 x 6 rm	7	3.12	0.7
3 x 10 rm	7	4.01	0.7
3 x 16 rm	7	5.03	0.7
3 x 25 sm	7	-	0.9
3 x 35 sm	7	-	0.9
3 x 50 sm	19	-	1.0
3 x 70 sm	19	-	1.1
3 x 95 sm	19	-	1.1
3 x 120 sm	37	-	1.2
3 x 150 sm	37	-	1.4
3 x 185 sm	37	-	1.6
3 x 240 sm	61	-	1.7
3 x 300 sm	61	-	1.8
3 x 400 sm	61	-	2.0
3 x 500 sm	61	-	2.2

Nominal Sheath Thickness	Approx. Overall diameter	Approx. Weight	Stranded Packing
mm	mm	Kg/Km	meters
1.8	13	200	1000
1.8	12	210	1000
1.8	13	250	1000
1.8	13	260	1000
1.8	14	325	1000
1.8	15	335	1000
1.8	15	400	1000
1.8	16	410	1000
1.8	18	525	1000
1.8	20	725	1000
1.8	21	1000	1000
1.8	23	1300	1000
1.8	26	1690	1000
1.9	30	2370	500
2.0	34	3140	500
2.1	37	3900	500
2.3	42	4830	500
2.4	46	5970	500
2.6	51	7750	250
2.8	56	9580	250
3.1	64	12150	250
3.3	70	15470	250

re: Round Solid
rm: Round Stranded
sm: Sectoral Stranded

Colour Code :
 3 Cores : Red, Yellow, Blue

Tolerance Range:
 Overall diameter ±5%
 Packing ±5%



XLPE INSULATED, PVC SHEATHED CABLES

COPPER CONDUCTOR

STANDARD: IEC 60502-1

0.6/1 kV



STEEL WIRE ARMoured

Steel Wire Diameter	Nominal Sheath Thickness	Approx. Overall diameter	Approx. Weight	Standard Packing
mm	mm	mm	Kg/Km	meters
-	-	-	-	-
0.8	1.8	14	370	1000
-	-	-	-	-
0.8	1.8	15	440	1000
-	-	-	-	-
0.8	1.8	16	530	1000
0.8	1.8	17	575	1000
0.8	1.8	17	630	1000
1.25	1.8	20	900	1000
1.25	1.8	23	1160	1000
1.6	1.8	25	1600	1000
1.6	1.8	27	1970	1000
1.6	1.9	30	2460	1000
2.0	2.0	35	3480	500
2.0	2.2	41	4600	500
2.0	2.3	41	5270	500
2.5	2.5	47	6790	500
2.5	2.6	51	8100	250
2.5	2.8	57	10130	250
2.5	3.0	62	12190	250
2.5	3.2	69	15070	250
3.15	3.5	77	19580	250

STEEL TAPE ARMoured

Steel Tape Thickness	Nominal Sheath Thickness	Approx. Overall diameter	Approx. Weight	Standard Packing
mm	mm	mm	Kg/Km	meters
-	-	-	-	-
0.2	1.8	13	275	1000
-	-	-	-	-
0.2	1.8	14	310	1000
-	-	-	-	-
0.2	1.8	15	390	1000
0.2	1.8	16	475	1000
0.2	1.8	17	470	1000
0.2	1.8	19	630	1000
0.2	1.8	21	850	1000
0.2	1.8	22	1130	1000
0.2	1.8	24	1430	1000
0.2	1.8	27	1845	1000
0.2	1.9	31	2550	500
0.2	2.1	35	3360	500
0.5	2.2	40	4490	500
0.5	2.4	44	5490	500
0.5	2.5	48	6700	500
0.5	2.7	53	8560	250
0.5	2.9	58	10480	250
0.5	3.1	65	13130	250
0.5	3.3	73	16560	250



XLPE INSULATED, PVC SHEATHED CABLES

COPPER CONDUCTOR

STANDARD:IEC 60502-1

0.6/1 kV



CABLE CORE(S)

Nominal Area	No. of Wires	Approx. Conductor diameter	Nominal Insulation Thickness
mm ²	No.	mm	mm
4 x 1.5 re	1	1.38	0.7
4 x 1.5 rm	7	1.56	0.7
4 x 2.5 re	1	1.78	0.7
4 x 2.5 rm	7	2.01	0.7
4 x 4 re	1	2.25	0.7
4 x 4 rm	7	2.55	0.7
4 x 6 re	1	2.76	0.7
4 x 6 rm	7	3.12	0.7
4 x 10 re	1	3.57	0.7
4 x 10 rm	7	4.01	0.7
4 x 16 rm	7	5.03	0.7
4 x 25 sm	7	-	0.9
4 x 35 sm	7	-	0.9
4 x 50 sm	19	-	1.0
4 x 70 sm	19	-	1.1
4 x 95 sm	19	-	1.1
4 x 120 sm	37	-	1.2
4 x 150 sm	37	-	1.4
4 x 185 sm	37	-	1.6
4 x 240 sm	61	-	1.7
4 x 300 sm	61	-	1.8
4 x 400 sm	61	-	2.0
4 x 500 sm	61	-	2.2

UNARMoured

Nominal Sheath Thickness	Approx. Overall diameter	Approx. Weight	Standard Packing
mm	mm	Kg/Km	meters
1.8	14	250	1000
1.8	13	250	1000
1.8	15	300	1000
1.8	14	300	1000
1.8	16	400	1000
1.8	16	390	1000
1.8	18	500	1000
1.8	17	490	1000
1.8	20	650	1000
1.8	19	650	1000
1.8	22	900	1000
1.8	26	1350	1000
1.8	26	1650	1000
1.9	30	2180	1000
2.0	34	3050	500
2.1	38	4100	500
2.3	42	5125	500
2.4	47	6290	500
2.6	52	7815	500
2.8	58	10150	250
3.0	64	12590	250
3.3	73	16090	250
3.5	80	20380	250

re: Round Solid
rm: Round Stranded
sm : Sectoral Stranded

Colour Code :
 4 Cores : Red, Yellow, Blue, Black

Tolerance range:
 Overall diameter ±5%
 Packing ±5%



XLPE INSULATED, PVC SHEATHED CABLES

COPPER CONDUCTOR

STANDARD: IEC 60502-1

0.6/1 kV

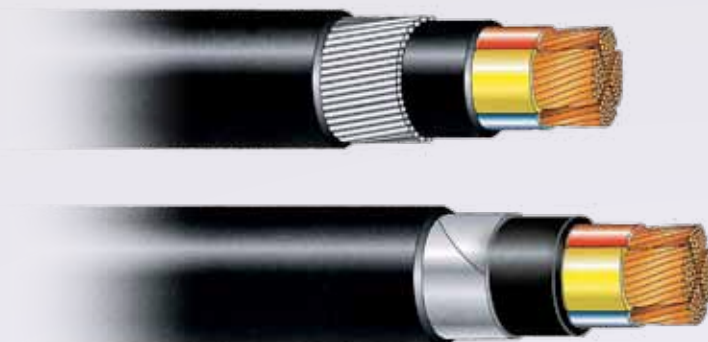

STEEL WIRE ARMoured

Steel Wire dia.	Nominal Sheath thickness	Approx. Overall diameter	Approx. Weight	Standard Packing
mm	mm	mm	Kg/Km	meters
0.8	1.8	15	410	1000
0.8	1.8	15	400	1000
0.8	1.8	16	490	1000
0.8	1.8	16	475	1000
0.8	1.8	17	550	1000
0.8	1.8	17	600	1000
1.25	1.8	19	775	1000
1.25	1.8	20	825	1000
1.25	1.8	22	1010	1000
1.25	1.8	22	1060	1000
1.6	1.8	25	1525	1000
1.6	1.8	29	2075	1000
1.6	1.9	29	2400	1000
1.6	2.0	33	3030	1000
2.0	2.2	38	4320	500
2.0	2.3	42	5500	500
2.5	2.5	48	7080	500
2.5	2.6	52	8460	500
2.5	2.8	57	10200	250
2.5	3.0	63	12850	250
2.5	3.2	69	15540	250
3.15	3.5	79	20325	250
3.15	3.8	87	25075	250

STEEL TAPE ARMoured

Steel Tape Thickness	Nominal Sheath Thickness	Approx. Overall diameter	Approx. Weight	Standard Packing
mm	mm	mm	Kg/Km	meters
-	-	-	-	-
0.2	1.8	14	300	1000
-	-	-	-	-
0.2	1.8	15	360	1000
0.2	1.8	16	455	1000
0.2	1.8	16	450	1000
0.2	1.8	17	560	1000
0.2	1.8	18	555	1000
0.2	1.8	19	750	1000
0.2	1.8	20	760	1000
0.2	1.8	23	1030	1000
0.2	1.8	24	1400	1000
0.2	1.8	27	1800	1000
0.2	1.9	31	2360	500
0.2	2.0	35	3280	500
0.5	2.2	40	4700	500
0.5	2.4	45	5800	500
0.5	2.5	49	7040	500
0.5	2.7	54	8650	500
0.5	2.9	60	11080	500
0.5	3.1	66	13620	500
0.5	3.4	75	17250	500
0.8	3.7	84	22450	250



XLPE INSULATED, PVC SHEATHED CABLES

ALUMINIUM CONDUCTOR

STANDARD: IEC 60502-1

0.6/1 kV



CABLE CORE(S)

Nominal Area	No. of wires	Approx. conductor diameter	Nominal Insulation Thickness
mm ²	No.	mm	mm
1 x 16 rm	7	5.20	0.7
1 x 25 rm	7	6.30	0.9
1 x 35 rm	7	7.41	0.9
1 x 50 rmc	7	8.30	1.0
1 x 70 rmc	19	9.70	1.1
1 x 95 rmc	19	11.55	1.1
1 x 120 rmc	37	12.95	1.2
1 x 150 rmc	37	14.3	1.4
1 x 185 rmc	37	15.9	1.6
1 x 240 rmc	61	18.4	1.7
1 x 300 rmc	61	20.5	1.8
1 x 400 rmc	61	24.0	2.0
1 x 500 rmc	61	27.0	2.2
1 x 630 rmc	61	30.4	2.4

UNARMoured

Nominal Sheath Thickness	Approx. Overall Diameter	Approx. Weight	Standard Packing
mm	mm	Kg/Km	meters
1.4	10	110	1000
1.4	11	150	1000
1.4	12	200	1000
1.4	13	230	1000
1.4	15	300	1000
1.5	18	400	1000
1.5	19	490	1000
1.6	20	590	1000
1.6	23	720	1000
1.7	25	930	1000
1.8	28	1130	1000
1.9	32	1500	500
2.0	35	1820	500
2.2	40	2320	500

CABLE CORE(S)

2 x 16 rm	7	5.20	0.7
2 x 25 rm	7	6.30	0.9
2 x 35 rm	7	7.41	0.9

UNARMoured

1.8	19	460	1000
1.8	22	630	1000
1.8	24	770	1000

CABLE CORE(S)

3 x 16 rm	7	5.10	0.7
3 x 25 rm	7	6.30	0.9
3 x 35 rm	7	7.41	0.9
3 x 50 rmc	19	8.30	1.0
3 x 70 rmc	19	9.7	1.1
3 x 95 rmc	19	11.55	1.1
3 x 120 rmc	37	12.95	1.2
3 x 150 rmc	37	14.3	1.4
3 x 185 rmc	37	15.9	1.6
3 x 240 rmc	61	18.4	1.7
3 x 300 rmc	61	20.5	1.8
3 x 400 rmc	61	24.0	2.0
3 x 500 rmc	61	27.0	2.2

UNARMoured

1.8	21	450	1000
1.8	24	600	1000
1.8	26	750	1000
1.8	29	880	1000
1.9	34	1180	500
2.0	37	1530	500
2.1	40	1840	500
2.3	45	2290	500
2.4	49	2780	250
2.6	56	3600	250
2.8	61	4350	250
3.1	70	5570	250
3.3	79	7010	250

re: Round Solid
rm: Round Stranded
rmc: Round Stranded Compacted

Colour Code:
 1 Core: Black (Red on request)
 2 Cores: Red, Black
 3 Cores: Red, Yellow, Blue

Tolerance range:
 Overall diameter ± 5%
 Packing ± 5%



XLPE INSULATED, PVC SHEATHED CABLES

ALUMINIUM CONDUCTOR

STANDARD: IEC 60502-1

0.6/1 kV



ALUMINIUM WIRE ARMoured

Nominal Alum / Steel Wire Diameter	Nominal Sheath Thickness	Approx. Overall diameter	Approx. Weight	Standard Packing
mm	mm	mm	Kg/Km	meters
0.8	1.8	14	255	1000
0.8	1.8	16	320	1000
0.8	1.8	17	370	1000
1.25	1.8	19	470	1000
1.25	1.8	20	570	1000
1.25	1.8	22	690	1000
1.6	1.8	24	840	1000
1.6	1.8	26	980	1000
1.6	1.8	28	1130	1000
1.6	1.9	30	1400	500
1.6	1.9	33	1620	500
2.0	2.1	39	2170	500
2.0	2.2	42	2610	250
2.0	2.3	46	3170	250

ALUMINIUM TAPE ARMoured

Aluminium / Steel tape Thickness	Nominal Sheath Thickness	Approx. Overall diameter	Approx. Weight	Standard Packing
mm	mm	mm	Kg/Km	meters
-	-	-	-	-
-	-	-	-	-
-	-	-	-	-
0.5	1.8	17	420	500
0.5	1.8	19	520	500
0.5	1.8	20	630	500
0.5	1.8	22	730	500
0.5	1.8	24	850	500
0.5	1.8	26	1000	500
0.5	1.8	28	1240	500
0.5	1.9	31	1470	500
0.5	2.0	35	1870	500
0.5	2.1	40	2650	250
0.5	2.3	44	3240	250

STEEL WIRE ARMoured

1.25	1.8	22	880	1000
1.6	1.8	25	1270	1000
1.6	1.8	28	1470	1000

STEEL TAPE ARMoured

0.2	1.8	20	570	1000
0.2	1.8	23	750	1000
0.2	1.8	25	900	500

STEEL WIRE ARMoured

1.25	1.8	23	880	1000
1.6	1.8	27	1275	1000
1.6	1.8	29	1480	1000
1.6	1.9	32	1720	500
2.0	2.0	37	2370	500
2.0	2.2	41	2900	500
2.0	2.3	45	3350	500
2.5	2.5	50	4370	500
2.5	2.6	55	5080	250
2.5	2.8	62	6200	250
2.5	3.0	67	7200	250
2.5	3.2	76	8770	250
3.15	3.5	85	11580	250

STEEL TAPE ARMoured

0.2	1.8	21	570	1000
0.2	1.8	25	750	1000
0.2	1.8	27	900	500
0.2	1.8	30	1050	500
0.2	1.9	33	1380	500
0.5	2.1	38	1770	500
0.5	2.2	43	2490	500
0.5	2.4	47	3000	250
0.5	2.5	52	3570	250
0.5	2.7	58	4500	250
0.5	2.9	64	5330	250
0.5	3.1	72	6660	250
0.5	3.3	81	8240	250



XLPE INSULATED, PVC SHEATHED CABLES

ALUMINIUM CONDUCTOR

STANDARD: IEC 60502-1

0.6/1 kV



CABLE CORE(S)

Nominal Area	No. of Wires	Approx. Conductor diameter	Nominal Insulation Thickness
mm ²	No.	mm	mm
4 x 16 rm	7	5.2	0.7
4 x 25 rm	7	6.30	0.9
4 x 35 sm	7	-	0.9
4 x 50 sm	19	-	1.0
4 x 70 sm	19	-	1.1
4 x 95 sm	19	-	1.1
4 x 120 sm	37	-	1.2
4 x 150 sm	37	-	1.4
4 x 185 sm	37	-	1.6
4 x 240 sm	37	-	1.7
4 x 300 sm	61	-	1.8
4 x 400 sm	61	-	2.0
4 x 500 sm	61	-	2.2

UNARMoured

Nominal Sheath Thickness	Approx. Overall diameter	Approx. Weight	Standard Packing
mm	mm	Kg/Km	meters
1.8	22	540	1000
1.8	26	740	1000
1.8	26	800	1000
1.9	30	1025	1000
2.0	34	1400	500
2.1	38	1780	500
2.3	42	2200	500
2.4	47	2670	500
2.6	52	3275	250
2.8	58	4225	250
3.0	64	5130	250
3.3	72	6550	250
3.5	80	8150	250

rm: Round Stranded
sm: Sectoral Stranded

Colour Code :
4 Cores: Red, Yellow, Blue, Black

Tolerance Range:
Overall diameter ±5%
Packing ±5%



XLPE INSULATED, PVC SHEATHED CABLES

ALUMINIUM CONDUCTOR

STANDARD: IEC 60502-1

0.6/1 kV

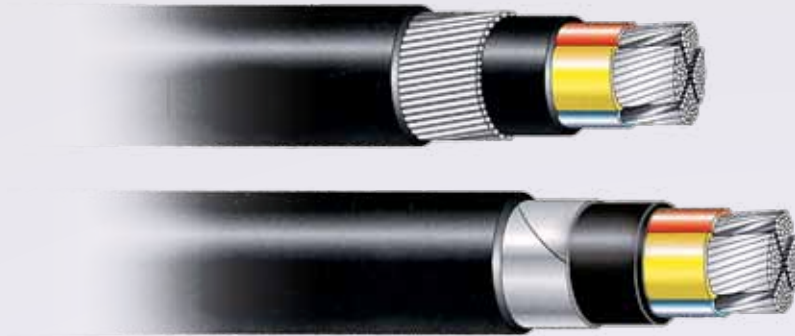

STEEL WIRE ARMoured

Steel Wire Diameter	Nominal Sheath Thickness	Approx. Overall diameter	Approx. Weight	Standard Packing
mm	mm	mm	Kg/Km	meters
1.6	1.8	26	1160	1000
1.6	1.8	29	1475	1000
1.6	1.9	30	1550	500
1.6	2.0	33	1890	500
2.0	2.2	39	2670	500
2.0	2.3	43	3190	500
2.5	2.5	48	4170	500
2.5	2.6	52	4840	500
2.5	2.8	57	5670	250
2.5	3.0	63	6900	250
2.5	3.2	69	8070	250
3.15	3.5	79	10800	250
3.15	3.8	87	12840	250

STEEL TAPE ARMoured

Steel Tape Thickness	Nominal Sheath Thickness	Approx. Overall diameter	Approx. Weight	Standard Packing
mm	mm	mm	Kg/Km	meters
0.2	1.8	23	670	1000
0.2	1.8	27	890	1000
0.2	1.8	27	960	500
0.2	1.9	31	1200	500
0.2	2.0	35	1600	500
0.5	2.2	40	2390	500
0.5	2.4	45	2890	250
0.5	2.5	49	3420	250
0.5	2.7	54	4100	250
0.5	2.9	60	5150	250
0.5	3.1	66	6150	250
0.5	3.4	75	7725	250
0.8	3.7	84	10240	250



XLPE INSULATED, LSZH SHEATHED CABLES

COPPER CONDUCTOR

STANDARD: IEC 60502-1

0.6/1 kV



CABLE CORE(S)

Nominal Area	No. of wires	Approx. conductor diameter	Nominal Insulation Thickness
mm ²	No.	mm	mm
1 x 1.5 re	1	1.38	0.7
1 x 1.5 rm	7	1.56	0.7
1 x 2.5 re	1	1.8	0.7
1 x 2.5 rm	7	1.98	0.7
1 x 4 re	1	2.25	0.7
1 x 4 rm	7	2.52	0.7
1 x 6 re	1	2.76	0.7
1 x 6 rm	7	3.12	0.7
1 x 10 rm	7	4.01	0.7
1 x 16 rm	7	5.03	0.7
1 x 25 rm	7	6.3	0.9
1 x 35 rm	7	7.44	0.9
1 x 50 rmc	19	8.1	1.0
1 x 70 rmc	19	9.7	1.1
1 x 95 rmc	19	11.4	1.1
1 x 120 rmc	37	12.9	1.2
1 x 150 rmc	37	14.3	1.4
1 x 185 rmc	37	16.0	1.6
1 x 240 rmc	61	18.4	1.7
1 x 300 rmc	61	20.4	1.8
1 x 400 rmc	61	23.2	2.0
1 x 500 rmc	61	26.7	2.2
1 x 630 rmc	61	30.4	2.4

UNARMoured

Nominal Sheath Thickness	Approx. Overall Diameter	Approx. Weight	Standard Packing
mm	no.	Kg/Km	meters
1.4	6	45	1000
1.4	6	50	1000
1.4	6	60	1000
1.4	7	60	1000
1.4	7	75	1000
1.4	7	80	1000
1.4	7	95	1000
1.4	8	100	1000
1.4	9	145	1000
1.4	10	200	1000
1.4	11	300	1000
1.4	12	400	1000
1.4	13	520	1000
1.4	15	720	1000
1.5	17	990	1000
1.5	18	1210	1000
1.6	20	1490	1000
1.6	22	1860	1000
1.7	25	2420	1000
1.8	27	3020	1000
1.9	31	3850	1000
2.0	35	4900	500
2.2	40	6250	500

CABLE CORE(S)

2 x 1.5 re	1	1.38	0.7
2 x 1.5 rm	7	1.56	0.7
2 x 2.5 re	1	1.78	0.7
2 x 2.5 rm	7	1.98	0.7
2 x 4 re	1	2.25	0.7
2 x 4 rm	7	2.52	0.7
2 x 6 re	1	2.76	0.7
2 x 6 rm	7	3.12	0.7
2 x 10 re	1	4.01	0.7
2 x 16 rm	7	5.03	0.7
2 x 25 rm	7	6.3	0.9
2 x 35 rm	7	7.44	0.9

UNARMoured

1.8	12	175	1000
1.8	12	190	1000
1.8	13	225	1000
1.8	13	225	1000
1.8	14	275	1000
1.8	14	275	1000
1.8	15	325	1000
1.8	15	350	1000
1.8	17	470	1000
1.8	19	640	1000
1.8	22	925	1000
1.8	24	1185	1000

re: Round Solid
rm: Round Stranded

Colour Code:
1 Core: Black (red on request)
2 Cores: Red, Black

Tolerance range:
Overall diameter ± 5%
Packing ± 5%



XLPE INSULATED, LSZH SHEATHED CABLES

COPPER CONDUCTOR

STANDARD: IEC 60502-1

0.6/1 kV



ALUMINIUM WIRE ARMoured

Nominal Alum./ Steel Wire diameter	Nominal Sheath Thickness	Approx. Overall diameter	Approx. Weight	Standard Packing
mm	mm	mm	Kg/Km	meters
-	-	-	-	-
0.8	1.8	11	150	1000
-	-	-	-	-
0.8	1.8	11	150	1000
-	-	-	-	-
0.8	1.8	12	200	1000
-	-	-	-	-
0.8	1.8	12	210	1000
0.8	1.8	13	275	1000
0.8	1.8	14	340	1000
0.8	1.8	16	460	1000
0.8	1.8	17	575	1000
1.25	1.8	18	740	1000
1.25	1.8	20	980	1000
1.25	1.8	21	1260	1000
1.6	1.8	24	1560	1000
1.6	1.8	26	1880	1000
1.6	1.8	27	2270	1000
1.6	1.9	30	2870	500
1.6	1.9	33	3500	500
2.0	2.1	38	4550	500
2.0	2.2	42	5680	500
2.0	2.3	47	7075	500

ALUMINIUM TAPE ARMoured

Aluminium/ Steel Tape Thickness	Nominal Sheath Thickness	Approx. Overall diameter	Approx. Weight	Standard Packing
mm	mm	mm	Kg/Km	meters
-	-	-	-	-
-	-	-	-	-
-	-	-	-	-
-	-	-	-	-
-	-	-	-	-
-	-	-	-	-
-	-	-	-	-
-	-	-	-	-
-	-	-	-	-
0.5	1.8	16	475	1000
0.5	1.8	17	580	1000
0.5	1.8	18	700	1000
0.5	1.8	19	930	1000
0.5	1.8	21	1210	1000
0.5	1.8	22	1460	1000
0.5	1.8	24	1760	1000
0.5	1.8	26	2130	1000
0.5	1.8	29	2710	500
0.5	1.9	31	3340	500
0.5	2.0	36	4250	500
0.5	2.1	40	5350	500
0.5	2.3	43	6950	500

STEEL WIRE ARMoured

0.8	1.8	14	-	-
-	-	-	-	-
0.8	1.8	15	-	-
-	-	-	-	-
0.8	1.8	15	450	1000
0.8	1.8	16	460	1000
0.8	1.8	16	525	1000
0.8	1.8	17	550	1000
1.25	1.8	19	835	1000
1.25	1.8	21	1050	1000
1.6	1.8	25	1560	1000
1.6	1.8	28	1890	1000

STEEL TAPE ARMoured

-	-	-	-	-
-	-	-	-	-
-	-	-	-	-
-	-	-	-	-
0.2	1.8	15	350	1000
0.2	1.8	15	360	1000
0.2	1.8	16	400	1000
0.2	1.8	16	430	1000
0.2	1.8	18	570	1000
0.2	1.8	20	750	1000
0.2	1.8	24	1050	1000
0.2	1.8	26	1330	1000



XLPE INSULATED, LSZH SHEATHED CABLES

COPPER CONDUCTOR STANDARD:IEC 60502-1 0.6/1 kV



CABLE CORE(S)

Nominal Area	No. of Wires	Approx. Conductor diameter	Nominal Insulation Thickness
mm ²	No.	mm	mm
3 x 1.5 re	1	1.38	0.7
3 x 1.5 rm	7	1.56	0.7
3 x 2.5 re	1	1.78	0.7
3 x 2.5 rm	7	2.01	0.7
3 x 4 re	1	2.25	0.7
3 x 4 rm	7	2.55	0.7
3 x 6 re	1	2.76	0.7
3 x 6 rm	7	3.12	0.7
3 x 10 rm	7	4.01	0.7
3 x 16 rm	7	5.03	0.7
3 x 25 sm	7	-	0.9
3 x 35 sm	7	-	0.9
3 x 50 sm	19	-	1.0
3 x 70 sm	19	-	1.1
3 x 95 sm	19	-	1.1
3 x 120 sm	37	-	1.2
3 x 150 sm	37	-	1.4
3 x 185 sm	37	-	1.6
3 x 240 sm	61	-	1.7
3 x 300 sm	61	-	1.8
3 x 400 sm	61	-	2.0
3 x 500 sm	61	-	2.2

UNARMoured

Nominal Sheath Thickness	Approx. Overall diameter	Approx. Weight	Standard Packing
mm	mm	Kg/Km	meters
1.8	13	200	1000
1.8	12	200	1000
1.8	13	250	1000
1.8	13	250	1000
1.8	14	325	1000
1.8	14	325	1000
1.8	15	400	1000
1.8	15	400	1000
1.8	18	525	1000
1.8	20	725	1000
1.8	24	1050	1000
1.8	26	1375	1000
1.8	28	1725	1000
1.9	32	2425	500
2.0	36	3250	500
2.1	40	4025	500
2.3	45	5000	500
2.4	50	6150	500
2.6	56	8025	500
2.8	61	9925	500
3.1	69	12600	250
3.3	78	16100	250

re: Round Solid
 rm: Round Stranded
 sm: Sectoral Stranded

Colour Code :
 3 Cores : Red, Yellow, Blue

Tolerance Range:
 Overall diameter ±5%
 Packing ±5%



XLPE INSULATED, LSZH SHEATHED CABLES

COPPER CONDUCTOR

STANDARD: IEC 60502-1

0.6/1 kV



STEEL WIRE ARMoured

Steel Wire Diameter	Nominal Sheath Thickness	Approx. Overall diameter	Approx. Weight	Standard Packing
mm	mm	mm	Kg/Km	meters
-	-	-	-	-
0.8	1.8	14	350	-
-	-	-	-	-
0.8	1.8	15	400	-
-	-	-	-	-
0.8	1.8	16	490	1000
0.8	1.8	17	575	1000
0.8	1.8	17	590	1000
1.25	1.8	20	900	1000
1.25	1.8	22	1150	1000
1.6	1.8	25	1600	1000
1.6	1.8	27	1960	1000
1.6	1.9	30	2450	1000
2.0	2.0	35	3470	500
2.0	2.2	38	4400	500
2.0	2.3	41	5260	500
2.5	2.5	47	6770	500
2.5	2.6	51	8090	500
2.5	2.8	56	10120	500
2.5	3.0	62	12170	250
2.5	3.2	74	15725	250
3.15	3.5	85	20650	250

STEEL TAPE ARMoured

Steel Tape Thickness	Nominal Sheath Thickness	Approx. Overall diameter	Approx. Weight	Standard Packing
mm	mm	mm	Kg/Km	meters
-	-	-	-	-
0.2	1.8	13	260	-
-	-	-	-	-
0.2	1.8	14	325	-
-	-	-	-	-
0.2	1.8	15	380	1000
0.2	1.8	16	475	1000
0.2	1.8	17	470	1000
0.2	1.8	19	625	1000
0.2	1.8	21	840	1000
0.2	1.8	25	1200	1000
0.2	1.8	24	1430	1000
0.2	1.8	27	1850	1000
0.2	2.0	31	2550	500
0.2	2.1	35	3360	500
0.5	2.2	39	4480	500
0.5	2.4	44	5480	500
0.5	2.5	49	6690	500
0.5	2.7	53	8550	500
0.5	2.9	56	10460	250
0.5	3.1	66	13120	250
0.5	3.3	73	16540	250



XLPE INSULATED, LSZH SHEATHED CABLES

COPPER CONDUCTOR

STANDARD: IEC 60502-1

0.6/1 kV



CABLE CORES

Nominal Area	No. of Wires	Approx. Conductor diameter	Nominal Insulation Thickness
mm ²	No.	mm	mm
4 x 1.5 re	1	1.38	0.7
4 x 1.5 rm	7	1.56	0.7
4 x 2.5 re	1	1.78	0.7
4 x 2.5 rm	7	1.98	0.7
4 x 4 re	1	2.25	0.7
4 x 4 rm	7	2.52	0.7
4 x 6 re	1	2.76	0.7
4 x 6 rm	7	3.12	0.7
4 x 10 rm	7	4.01	0.7
4 x 16 rm	7	5.03	0.7
4 x 25 sm	7	-	0.9
4 x 35 sm	7	-	0.9
4 x 50 sm	19	-	1.0
4 x 70 sm	19	-	1.1
4 x 95 sm	19	-	1.1
4 x 120 sm	37	-	1.2
4 x 150 sm	37	-	1.4
4 x 185 sm	37	-	1.6
4 x 240 sm	37	-	1.7
4 x 300 sm	61	-	1.8
4 x 400 sm	61	-	2.0
4 x 500 sm	61	-	2.2

UNARMoured

Nominal Sheath Thickness	Approx. Overall diameter	Approx. Weight	Standard Packing
mm	mm	Kg/Km	meters
1.8	13	225	1000
1.8	13	225	1000
1.8	14	300	1000
1.8	14	280	1000
1.8	15	375	1000
1.8	15	360	1000
1.8	17	475	1000
1.8	17	450	1000
1.8	19	640	1000
1.8	22	900	1000
1.8	24	1260	1000
1.8	26	1650	1000
1.9	30	2175	1000
2.0	34	3070	500
2.1	38	4090	500
2.3	43	5120	500
2.4	47	6280	500
2.6	52	7810	500
2.8	58	10140	250
3.0	64	12590	250
3.3	73	16060	250
3.5	80	20340	250

re: Round Solid
rm: Round Stranded
sm : Sectoral Stranded

Colour Code :
4 Cores : Red, Yellow, Blue, Black

Tolerance range:
Overall diameter ±5%
Packing ±5%



XLPE INSULATED, LSZH SHEATHED CABLES

COPPER CONDUCTOR

STANDARD: IEC 60502-1

0.6/1 kV

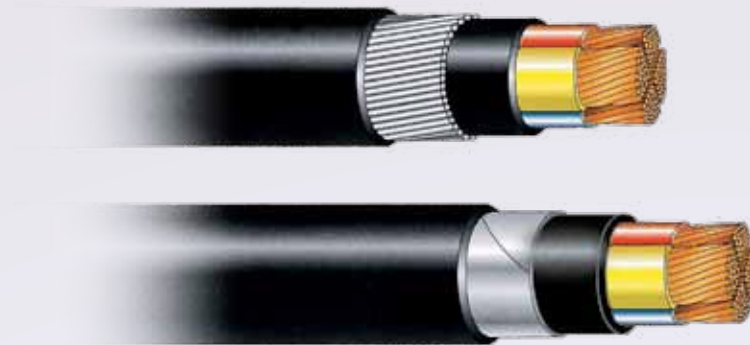

STEEL WIRE ARMoured

Steel Wire dia.	Nominal Sheath thickness	Approx. Overall diameter	Approx. Weight	Standard Packing
mm	mm	mm	Kg / Km	meters
-	-	-	-	-
0.8	1.8	15	400	1000
-	-	-	-	-
0.8	1.8	16	460	1000
-	-	-	-	-
0.8	1.8	17	560	1000
1.25	1.8	19	800	1000
1.25	1.8	19	810	1000
1.25	1.8	22	1050	1000
1.6	1.8	25	1525	1000
1.6	1.8	27	1930	1000
1.6	1.9	30	2400	1000
1.6	2.0	33	3030	1000
2.0	2.2	38	4330	500
2.0	2.3	42	5490	500
2.5	2.5	48	7075	500
2.5	2.6	52	8450	500
2.5	2.8	57	10200	250
2.5	3.0	63	12825	250
2.5	3.2	69	15530	250
3.15	3.5	79	20300	250
3.15	3.8	87	25025	250

STEEL TAPE ARMoured

Steel Tape Thickness	Nominal Sheath Thickness	Approx. Overall diameter	Approx. Weight	Standard Packing
mm	mm	mm	Kg/Km	meters
-	-	-	-	-
0.2	1.8	14	300	1000
-	-	-	-	-
0.2	1.8	15	360	1000
-	-	-	-	-
0.2	1.8	16	440	1000
0.2	1.8	17	550	1000
0.2	1.8	18	550	1000
0.2	1.8	20	750	1000
0.2	1.8	23	1025	1000
0.2	1.8	24	1400	1000
0.2	1.8	27	1800	1000
0.2	1.9	31	2360	1000
0.2	2.0	35	3270	500
0.5	2.2	40	4700	500
0.5	2.4	44	5790	500
0.5	2.5	49	7030	500
0.5	2.7	54	8040	500
0.5	2.9	60	11065	500
0.5	3.1	66	13600	250
0.5	3.4	75	17220	250
0.8	3.7	83	22420	250



XLPE INSULATED, LSZH SHEATHED CABLES

ALUMINIUM CONDUCTOR STANDARD: IEC 60502-1 0.6/1 kV



CABLE CORE(S)

Nominal Area	No. of wires	Approx. conductor diameter	Nominal Insulation Thickness
mm ²	No.	mm	mm
1 x 16 rm	7	5.2	0.7
1 x 25 rm	7	6.30	0.9
1 x 35 rm	7	7.41	0.9
1 x 50 rmc	7	8.30	1.0
1 x 70 rmc	19	9.7	1.1
1 x 95 rmc	19	11.5	1.1
1 x 120 rmc	19	12.95	1.2
1 x 150 rmc	19	14.3	1.4
1 x 185 rmc	37	15.9	1.6
1 x 240 rmc	37	18.4	1.7
1 x 300 rmc	37	20.5	1.8
1 x 400 rmc	37	24.0	2.0
1 x 500 rmc	37	27.0	2.2
1 x 630 rmc	61	30.4	2.4

UNARMoured

Nominal Sheath Thickness	Approx. Overall Diameter	Approx. Weight	Standard Packing
mm	mm	Kg/Km	meter
1.4	10	115	1000
1.4	11	150	1000
1.4	12	200	1000
1.4	13	225	1000
1.4	15	300	1000
1.5	17	400	1000
1.5	18	475	1000
1.6	20	590	1000
1.6	22	715	1000
1.7	25	925	500
1.8	28	1125	500
1.9	32	1450	500
2.0	35	1820	500
2.2	42	2310	500

CABLE CORE(S)

2 x 16 rm	7	5.2	0.7
2 x 25 rm	7	6.30	0.9
2 x 35 rm	7	7.41	0.9

UNARMoured

1.8	19	460	1000
1.8	23	625	1000
1.8	25	760	1000

CABLE CORE(S)

3 x 16 rm	7	5.2	0.7
3 x 25 rm	7	6.30	0.9
3 x 35 rm	7	7.41	0.9
3 x 50 rmc	7	8.30	1.0
3 x 70 rmc	19	9.7	1.1
3 x 95 rmc	19	11.5	1.1
3 x 120 rmc	19	12.95	1.2
3 x 150 rmc	19	14.3	1.4
3 x 185 rmc	37	15.9	1.6
3 x 240 rmc	37	18.4	1.7
3 x 300 rmc	37	20.5	1.8
3 x 400 rmc	61	24.0	2.0
3 x 500 rmc	61	27.0	2.2

UNARMoured

1.8	21	450	1000
1.8	24	600	1000
1.8	26	740	1000
1.8	28	875	500
1.9	32	1175	500
2.0	37	1525	500
2.1	40	1835	500
2.3	45	2275	500
2.4	49	2765	250
2.6	56	3585	250
2.8	61	4325	250
3.1	70	5550	250
3.3	79	6990	250

re: Round Solid
rm: Round Stranded
rmc: Round Stranded Compacted

Colour Code:
1 Core: Black (Red on request)
2 Cores: Red, Black
3 Cores: Red, Yellow, Blue

Tolerance range:
Overall diameter ± 5%
Packing ± 5%



XLPE INSULATED, LSZH SHEATHED CABLES

ALUMINUM CONDUCTOR STANDARD:IEC 60502-1 0.6/1 kV



ALUMINIUM WIRE ARMoured

Nominal Alum / Steel Wire Diameter	Nominal Sheath Thickness	Approx. Overall diameter	Approx. Weight	Standard Packing
mm	mm	mm	Kg/Km	meters
0.8	1.8	14	250	1000
0.8	1.8	16	315	1000
0.8	1.8	17	370	1000
1.25	1.8	19	475	1000
1.25	1.8	21	560	500
1.25	1.8	22	680	500
1.6	1.8	24	835	500
1.6	1.8	26	970	500
1.6	1.8	28	1130	500
1.6	1.9	31	1390	500
1.6	1.9	33	1615	500
2.0	2.1	39	2150	500
2.0	2.2	42	2600	500
2.0	2.3	46	3160	500

ALUMINIUM TAPE ARMoured

Aluminium / Steel Tape Thickness	Nominal Sheath Thickness	Approx. Overall diameter	Approx. Weight	Standard Packing
mm	mm	mm	Kg/Km	meters
-	-	-	-	-
-	-	-	-	-
-	-	-	-	-
0.5	1.8	18	420	500
0.5	1.8	20	510	500
0.5	1.8	21	625	500
0.5	1.8	23	725	500
0.5	1.8	25	850	500
0.5	1.8	27	1000	500
0.5	1.8	29	1230	500
0.5	1.9	32	1460	500
0.5	2.0	37	1850	500
0.5	2.1	40	2270	500
0.5	2.3	44	2810	500

STEEL WIRE ARMoured

1.25	1.8	22	870	1000
1.6	1.8	26	1260	1000
1.6	1.8	28	1470	1000

STEEL TAPE ARMoured

0.2	1.8	20	570	1000
0.2	1.8	24	750	1000
0.2	1.8	26	910	500

STEEL WIRE ARMoured

1.25	1.8	23	880	1000
1.6	1.8	27	1275	1000
1.6	1.8	30	1475	500
1.6	1.9	-	1715	500
2.0	2.0	37	2360	500
2.0	2.2	-	3080	500
2.0	2.3	45	3340	500
2.5	2.5	50	4360	500
2.5	2.6	55	5060	250
2.5	2.8	61	6180	250
2.5	3.0	67	7180	250
2.5	3.2	76	8750	250
3.15	3.5	85	11550	250

STEEL TAPE ARMoured

0.2	1.8	21	560	1000
0.2	1.8	25	745	1000
0.2	1.8	27	900	500
0.2	1.8	28	1050	500
0.2	1.9	33	1370	500
0.2	2.1	35	1625	500
0.5	2.3	43	2480	500
0.5	2.5	47	2995	500
0.5	2.6	51	3560	500
0.5	2.8	58	4490	250
0.5	3.0	64	5320	250
0.5	3.3	72	6650	250
0.5	3.5	80	8200	250



XLPE INSULATED, LSZH SHEATHED CABLES

ALUMINIUM CONDUCTOR STANDARD:IEC 60502-1 0.6/1 kV



CABLE CORE(S)

Nominal Area	No. of Wires	Approx. Conductor diameter	Nominal Insulation Thickness
mm ²	No.	mm	mm
4 x 16 rm	7	5.2	0.7
4 x 25 rm	7	6.3	0.9
4 x 35 sm	7	-	0.9
4 x 50 sm	7	-	1.0
4 x 70 sm	19	-	1.1
4 x 95 sm	19	-	1.1
4 x 120 sm	37	-	1.2
4 x 150 sm	37	-	1.4
4 x 185 sm	37	-	1.6
4 x 240 sm	61	-	1.7
4 x 300 sm	61	-	1.8
4 x 400 sm	61	-	2.0
4 x 500 sm	61	-	2.2

UNARMoured

Nominal Sheath Thickness	Approx. Overall diameter	Approx. Weight	Standard Packing
mm	mm	Kg/Km	meters
1.8	22	530	1000
1.8	26	725	1000
1.8	26	800	1000
1.9	30	1025	1000
2.0	34	1400	500
2.1	38	1775	500
2.3	42	2200	500
2.4	47	2650	500
2.6	52	3270	250
2.8	58	4200	250
3.0	63	5110	250
3.3	72	6535	250
3.5	80	8130	250

rm: Round Stranded
sm: Sectoral Stranded

Colour Code :
3½ Cores : Red, Yellow, Blue, Black
4 Cores: Red, Yellow, Blue, Black

Tolerance Range:
Overall diameter ±5%
Packing ±5%



XLPE INSULATED, LSZH SHEATHED CABLES

ALUMINIUM CONDUCTOR STANDARD: IEC 60502-1 0.6/1 kV



STEEL WIRE ARMoured

Steel Wire Diameter	Nominal Sheath Thickness	Approx. Overall diameter	Approx. Weight	Standard Packing
mm	mm	mm	Kg/Km	meters
1.6	1.8	26	1150	1000
1.6	1.8	29	1475	500
1.6	1.9	30	1550	500
1.6	2.0	33	1875	500
2.0	2.2	38	2650	500
2.0	2.3	42	3175	500
2.5	2.5	48	4150	500
2.5	2.6	52	4825	500
2.5	2.8	57	5650	250
2.5	3.0	63	6890	250
2.5	3.2	69	8050	250
3.15	3.5	79	10775	250
3.15	3.8	87	12810	250

STEEL TAPE ARMoured

Steel Tape Thickness	Nominal Sheath Thickness	Approx. Overall diameter	Approx. Weight	Standard Packing
mm	mm	mm	Kg/Km	meters
0.2	1.8	23	660	1000
0.2	1.8	27	880	500
0.2	1.8	27	960	500
0.2	1.9	30	1020	500
0.2	2.0	35	1600	500
0.5	2.2	40	2380	500
0.5	2.4	44	2880	250
0.5	2.5	49	3400	250
0.5	2.7	53	4100	250
0.5	2.9	60	5130	250
0.5	3.1	66	6130	250
0.5	3.4	75	7700	250
0.8	3.7	84	10210	250



XLPE INSULATED, LSZH SHEATHED CABLES

COPPER CONDUCTOR

STANDARD: BS 6724

0.6/1 kV



ALUMINIUM WIRE ARMoured CABLES

Nominal Area	No. of Wires	Approx. Conductor Diameter	Nominal Insulation Thickness	Nominal Alum / Steel Wire Diameter	Nominal Sheath Thickness	Approx. Overall Diameter	Approx. Weight	Standard Packing
mm ²	no.	mm	mm	mm	mm	mm	Kg/Km	mm
1 x 50 rmc	19	8.1	1.0	0.9	1.5	17	675	1000
1 x 70 rmc	19	9.7	1.1	1.25	1.5	20	925	1000
1 x 95 rmc	19	11.4	1.1	1.25	1.6	22	1200	1000
1 x 120 rmc	37	12.9	1.2	1.25	1.6	24	1450	1000
1 x 150 rmc	37	14.3	1.4	1.6	1.7	27	1850	1000
1 x 185 rmc	37	16.0	1.6	1.6	1.8	30	2250	1000
1 x 240 rmc	61	18.4	1.7	1.6	1.8	33	2850	1000
1 x 300 rmc	61	20.4	1.8	1.6	1.9	36	3475	500
1 x 400 rmc	61	23.2	2.0	2.0	2.0	41	4450	500
1 x 500 rmc	61	26.7	2.2	2.0	2.1	44	5575	500
1 x 630 rmc	61	30.4	2.4	2.0	2.2	49	7050	500
1 x 800 rmc	61	33.7	2.6	2.5	2.4	55	9050	500
1 x 1000 rm	91	41.0	2.8	2.5	2.5	61	11500	500

STEEL WIRE ARMoured CABLES

2 x 1.5 rm	7	1.56	0.6	0.9	1.3	12	275	1000
2 x 2.5 rm	7	2.01	0.7	0.9	1.4	14	350	1000
2 x 4 rm	7	2.55	0.7	0.9	1.4	15	425	1000
2 x 6 rm	7	3.12	0.7	0.9	1.4	16	500	1000
2 x 10 rm	7	4.01	0.7	0.9	1.5	18	650	1000
2 x 16 rm	7	5.03	0.7	1.25	1.5	20	975	1000
2 x 25 sm	7	-	0.9	1.25	1.6	24	1350	1000
2 x 35 sm	7	-	0.9	1.6	1.7	27	1850	1000

rm: Round Stranded
 rmc: Round Stranded Compacted
 sm: Sectoral Stranded

Standard Colour Code:

1 Core : Black (Red on request)
 2 Cores : Red, Black

Color code based on special request:

1 Core: Brown or Blue
 2 Cores: Brown, Blue



XLPE INSULATED, LSZH SHEATHED CABLES

COPPER CONDUCTOR STANDARD: BS 6724 0.6/1 kV



STEEL WIRE ARMoured CABLES

Nominal Area	No. of Wires	Approx. Conductor Diameter	Nominal Insulation Thickness	Nominal Alum / Steel Wire Diameter	Nominal Sheath Thickness	Approx. Overall Diameter	Approx. Weight	Standard Packing
mm ²	No.	mm	mm	mm	mm	mm	Kg/Km	mm
3 x 1.5 rm	7	1.56	0.6	0.9	1.3	13	300	1000
3 x 2.5 rm	7	2.01	0.7	0.9	1.4	14	400	1000
3 x 4 rm	7	2.55	0.7	0.9	1.4	15	475	1000
3 x 6 rm	7	3.12	0.7	0.9	1.4	17	575	1000
3 x 10 rm	7	4.02	0.7	1.25	1.5	20	850	1000
3 x 16 rm	7	5.03	0.7	1.25	1.6	22	1100	1000
3 x 25 sm	7	-	0.9	1.6	1.7	24	1590	1000
3 x 35 sm	7	-	0.9	1.6	1.8	26	1965	1000
3 x 50 sm	19	-	1.0	1.6	1.8	29	2440	1000
3 x 70 sm	19	-	1.1	1.6	1.9	32	3200	500
3 x 95 sm	19	-	1.1	2.0	2.1	37	4390	500
3 x 120 sm	37	-	1.2	2.0	2.2	40	5250	500
3 x 150 sm	37	-	1.4	2.5	2.3	46	6740	500
3 x 185 sm	37	-	1.6	2.5	2.4	50	8050	250
3 x 240 sm	61	-	1.7	2.5	2.6	55	9990	250
3 x 300 sm	61	-	1.8	2.5	2.7	60	12100	250
3 x 400 sm	61	-	2.0	2.5	2.9	67	14970	250

rm: Round Stranded
sm: Sectoral Stranded

Standard Colour Code:
 3 Core : Red, Yellow, Blue

Color code based on special request:
 3 Cores: Brown, Black, Grey



XLPE INSULATED, LSZH SHEATHED CABLES

COPPER CONDUCTOR STANDARD: BS 6724 0.6/1 kV



STEEL WIRE ARMoured CABLES

Nominal Area	No. of Wires	Approx. Conductor Diameter	Nominal Insulation Thickness	Nominal Steel Wire Diameter	Nominal Sheath Thickness	Approx. Overall Diameter	Approx. Weight	Standard Packing
mm ²	No.	mm	mm	mm	mm	mm	Kg / Km	mm
4 x 1.5 rm	7	1.56	0.6	0.9	1.3	13	350	1000
4 x 2.5 rm	7	2.01	0.7	0.9	1.4	15	450	1000
4 x 4 rm	7	2.55	0.7	0.9	1.4	16	550	1000
4 x 6 rm	7	3.12	0.7	1.25	1.5	19	750	1000
4 x 10 rm	7	4.01	0.7	1.25	1.5	21	1000	1000
4 x 16 rm	7	5.03	0.7	1.25	1.6	23	1325	1000
4 x 25 sm	7	-	0.9	1.6	1.7	26	1925	1000
4 x 35 sm	7	-	0.9	1.6	1.8	29	2390	1000
4 x 50 sm	19	-	1.0	1.6	1.9	32	3015	1000
4 x 70 sm	19	-	1.1	2.0	2.1	38	4300	500
4 x 95 sm	19	-	1.1	2.0	2.2	42	5480	500
4 x 120 sm	37	-	1.2	2.5	2.3	47	7035	500
4 x 150 sm	37	-	1.4	2.5	2.4	52	8410	500
4 x 185 sm	37	-	1.6	2.5	2.6	57	10125	250
4 x 240 sm	37	-	1.7	2.5	2.7	63	12725	250
4 x 300 sm	61	-	1.8	2.5	2.9	69	15400	250
4 x 400 sm	61	-	2.0	3.15	3.2	78	20175	250

STEEL WIRE ARMoured CABLES

5 x 1.5 rm	7	1.56	0.6	0.9	1.4	14	400	1000
5 x 2.5 rm	7	2.01	0.7	0.9	1.4	16	515	1000
5 x 4 rm	7	2.55	0.7	0.9	1.5	18	650	1000
5 x 6 rm	7	3.12	0.7	1.25	1.5	20	900	1000
5 x 10 rm	7	4.01	0.7	1.25	1.6	23	1190	1000
5 x 16 rm	7	5.03	0.7	1.6	1.7	27	1750	1000
5 x 25 rm	7	6.3	0.9	1.6	1.8	31	2450	1000
5 x 35 rm	7	7.44	0.9	1.6	1.9	34	3075	500
5 x 50 rmc	19	8.1	1.0	2.0	2.0	40	4040	500
5 x 70 rmc	19	9.7	1.1	2.0	2.2	46	5350	500

rm: Round Stranded
rmc: Round Stranded Compacted
sm: Sectoral Stranded

Standard Colour Code:
 4 Cores: Red, Yellow, Blue, Black
 5 Cores: Red, Yellow, Blue, Black, Green/Yellow

Color code based on special request:
 4 Cores: Blue, Brown, Black, Grey
 5 Cores: Green/Yellow, Blue, Brown, Black, Grey



ELECTRICAL PARAMETERS 0.6/1 kV

Low Voltage Single Core Cable (In Trefoil Formation)

Linear Resistance, Reactance and Voltage Drop of PVC Insulated (70°C) Copper Conductor at 50 Hertz

SIZE MM ²	R (DC) 20°C	R (DC) 70°C	R (AC) 70°C	X	Z	VD
1.5	12.1	14.47	14.47	0.197	14.47	20.25
2.5	7.41	8.86	8.86	0.186	8.86	12.47
4	4.61	5.51	5.51	0.171	5.51	7.81
6	3.08	3.68	3.68	0.162	3.68	5.27
10	1.83	2.19	2.19	0.151	2.19	3.19
16	1.15	1.37	1.37	0.140	1.38	2.04
25	0.727	0.87	0.87	0.130	0.86	1.34
35	0.524	0.627	0.627	0.123	0.64	1.00
50	0.387	0.46	0.46	0.118	0.47	0.76
70	0.268	0.321	0.321	0.112	0.34	0.56
95	0.193	0.231	0.231	0.108	0.25	0.43
120	0.153	0.183	0.184	0.104	0.21	0.36
150	0.124	0.148	0.149	0.102	0.18	0.31
185	0.0991	0.118	0.12	0.100	0.16	0.27
240	0.0754	0.0902	0.092	0.096	0.13	0.23
300	0.0601	0.0719	0.0746	0.094	0.12	0.20
400	0.0470	0.056	0.059	0.092	0.11	0.18
500	0.0366	0.043	0.0483	0.090	0.10	0.16
630	0.0283	0.033	0.039	0.087	0.10	0.14

- R (DC) 20°C :** DIRECT CURRENT RESISTANCE AT 20°C, Ohm / Km
R (DC) 70°C : DIRECT CURRENT RESISTANCE AT 70°C, Ohm / Km
R (AC) 70°C : ALTERNATING CURRENT RESISTANCE AT 70°C, Ohm / Km
X : REACTANCE, Ohm / Km
Z : IMPEDANCE, Ohm / Km
VD : VOLTAGE DROP, V / Amp. Km (Phase to Phase)



Linear Resistance, Reactance and Voltage Drop of PVC Insulated (70°C) Copper Conductor at 50 Hertz

SIZE MM ²	R (DC) 20°C	R (DC) 70°C	R (AC) 70°C	X	Z	VD
1.5	12.1	14.47	14.47	0.110	14.47	20.16
2.5	7.41	8.86	8.86	0.103	8.86	12.38
4	4.61	5.51	5.51	0.102	5.51	7.74
6	3.08	3.68	3.68	0.097	3.68	5.20
10	1.83	2.19	2.19	0.091	2.19	3.13
16	1.15	1.37	1.37	0.086	1.37	1.99
25	0.727	0.869	0.870	0.086	0.87	1.29
35	0.524	0.627	0.627	0.083	0.63	0.95
50	0.387	0.463	0.463	0.081	0.47	0.73
70	0.268	0.320	0.321	0.078	0.33	0.53
95	0.193	0.230	0.232	0.078	0.24	0.40
120	0.153	0.183	0.184	0.076	0.20	0.33
150	0.124	0.148	0.150	0.076	0.17	0.29
185	0.0991	0.118	0.121	0.076	0.14	0.25
240	0.0754	0.090	0.094	0.074	0.12	0.21
300	0.0601	0.071	0.076	0.074	0.11	0.18
400	0.047	0.056	0.062	0.074	0.10	0.16
500	0.0366	0.044	0.051	0.073	0.09	0.15
630	0.0283	0.033	0.042	0.072	0.08	0.13

R (DC) 20°C : DIRECT CURRENT RESISTANCE AT 20°C, Ohm / Km

R (DC) 70°C : DIRECT CURRENT RESISTANCE AT 70°C, Ohm / Km

R (AC) 70°C : ALTERNATING CURRENT RESISTANCE AT 70°C, Ohm / Km

X : REACTANCE, Ohm / Km

Z : IMPEDANCE, Ohm / Km

VD : VOLTAGE DROP, V / Amp. Km (Phase to Phase)



Linear Resistance, Reactance and Voltage Drop of XLPE Insulated (90°C) Copper Conductor at 50 Hertz

SIZE MM ²	R (DC) 20°C	R (DC) 90°C	R (AC) 90°C	X	Z	VD
1.5	12.1	15.42	15.42	0.181	15.42	21.55
2.5	7.41	9.44	9.44	0.171	9.44	13.26
4	4.61	5.870	5.870	0.156	5.87	8.30
6	3.08	3.92	3.92	0.148	3.92	5.59
10	1.83	2.330	2.330	0.138	2.336	3.37
16	1.15	1.466	1.466	0.136	1.47	2.17
25	0.727	0.927	0.927	0.126	0.94	1.42
35	0.524	0.668	0.668	0.119	0.68	1.05
50	0.387	0.493	0.493	0.115	0.51	0.80
70	0.268	0.34	0.342	0.110	0.36	0.59
95	0.193	0.246	0.246	0.102	0.27	0.45
120	0.153	0.195	0.196	0.099	0.22	0.37
150	0.124	0.158	0.159	0.098	0.19	0.32
185	0.0991	0.126	0.128	0.095	0.16	0.28
240	0.0754	0.096	0.098	0.093	0.13	0.23
300	0.0601	0.076	0.079	0.090	0.12	0.20
400	0.047	0.060	0.063	0.091	0.11	0.18
500	0.0366	0.046	0.051	0.088	0.10	0.16
630	0.0283	0.036	0.042	0.086	0.10	0.15

- R (DC) 20°C** : DIRECT CURRENT RESISTANCE AT 20°C, Ohm / Km
R (DC) 90°C : DIRECT CURRENT RESISTANCE AT 90°C, Ohm / Km
R (AC) 90°C : ALTERNATING CURRENT RESISTANCE AT 90°C, Ohm / Km
X : REACTANCE, Ohm / Km
Z : IMPEDANCE, Ohm / Km
VD : VOLTAGE DROP, V / Amp. Km (Phase to Phase)



Linear Resistance, Reactance and Voltage Drop of XLPE Insulated (90°C) Copper Conductor at 50 Hertz

SIZE MM ²	R (DC) 20°C	R (DC) 90°C	R (AC) 90°C	X	Z	VD
1.5	12.1	15.42	15.42	0.106	15.42	21.48
2.5	7.41	9.44	9.44	0.099	9.4	13.18
4	4.61	5.870	5.870	0.093	5.87	8.23
6	3.08	3.920	3.920	0.089	3.92	5.52
10	1.83	2.330	2.330	0.084	2.33	3.32
16	1.15	1.466	1.466	0.081	1.47	2.12
25	0.727	0.927	0.927	0.081	0.93	1.37
35	0.524	0.668	0.668	0.079	0.67	1.01
50	0.387	0.493	0.494	0.076	0.50	0.76
70	0.268	0.341	0.342	0.075	0.35	0.55
95	0.193	0.246	0.247	0.074	0.26	0.42
120	0.153	0.195	0.196	0.072	0.21	0.35
150	0.124	0.158	0.160	0.073	0.18	0.30
185	0.0991	0.126	0.13	0.073	0.15	0.25
240	0.0754	0.096	0.099	0.072	0.12	0.21
300	0.0601	0.076	0.081	0.071	0.11	0.19
400	0.047	0.060	0.065	0.071	0.10	0.16
500	0.0366	0.046	0.053	0.071	0.09	0.15
630	0.0283	0.036	0.044	0.070	0.08	0.13

- R (DC) 20°C** : DIRECT CURRENT RESISTANCE AT 20°C, Ohm / Km
R (DC) 90°C : DIRECT CURRENT RESISTANCE AT 90°C, Ohm / Km
R (AC) 90°C : ALTERNATING CURRENT RESISTANCE AT 90°C, Ohm / Km
X : REACTANCE, Ohm / Km
Z : IMPEDANCE, Ohm / Km
VD : VOLTAGE DROP, V / Amp. Km (Phase to Phase)



Linear Resistance, Reactance and Voltage Drop of XLPE Insulated (90°C) Aluminium Conductor at 50 Hertz

SIZE MM ²	R (DC) 20°C	R (DC) 90°C	R (AC) 90°C	X	Z	VD
16	1.91	2.45	2.45	0.1048	2.45	3.48
25	1.20	1.539	1.539	0.0987	1.53	2.22
35	0.868	1.106	1.106	0.094	1.11	1.63
50	0.641	0.817	0.817	0.092	0.82	1.23
70	0.443	0.564	0.565	0.088	0.57	0.87
95	0.320	0.408	0.408	0.088	0.42	0.66
120	0.253	0.323	0.323	0.0842	0.33	0.54
150	0.206	0.262	0.263	0.0812	0.28	0.45
185	0.164	0.209	0.21	0.083	0.23	0.38
240	0.125	0.159	0.161	0.079	0.18	0.31
300	0.100	0.127	0.129	0.079	0.152	0.26
400	0.0778	0.0992	0.102	0.078	0.13	0.22
500	0.0605	0.0771	0.0809	0.076	0.11	0.19
630	0.0469	0.059	0.0643	0.077	0.10	0.17

Low Voltage Cable (Multi Core) Linear Resistance, Reactance and Voltage Drop of XLPE Insulated (90°C) Aluminium Conductor at 50 Hertz

SIZE MM ²	R (DC) 20°C	R (DC) 90°C	R (AC) 90°C	X	Z	VD
16	1.91	2.44	2.44	0.079	2.44	3.46
25	1.20	1.53	1.53	0.081	1.53	2.20
35	0.868	1.106	1.106	0.079	1.11	1.61
50	0.641	0.817	0.817	0.076	0.82	1.21
70	0.443	0.564	0.564	0.075	0.57	0.86
95	0.320	0.408	0.408	0.073	0.41	0.64
120	0.253	0.322	0.323	0.072	0.33	0.52
150	0.206	0.262	0.263	0.072	0.27	0.44
185	0.164	0.209	0.210	0.073	0.22	0.37
240	0.125	0.159	0.161	0.072	0.18	0.30
300	0.100	0.127	0.13	0.071	0.15	0.25
400	0.0778	0.099	0.102	0.070	0.12	0.21
500	0.0605	0.077	0.0816	0.071	0.11	0.19
630	0.0469	0.059	0.065	0.070	0.10	0.16

R (DC) 20: Direct Current Resistance at 20°C, Ohm / Km

R (DC) 90: Direct Current Resistance at 90°C, Ohm / Km

R (AC) 90: Alternating Current Resistance at 90°C, Ohm / Km

X : Reactance, Ohm / Km

Z : Impedance, Ohm / Km

VD : Voltage Drop (Phase to Phase), V / A / Km



GUIDELINES FOR THE SELECTION OF THE REQUIRED SIZE OF CABLE

The required sizes of cable shall be selected based on the following steps:

Ampacity: Based on the required ampacity and the installation condition, a suitable size of cable can be selected.

Voltage Drop: The suitability of the above selected size shall be cross checked with the voltage drop. If it is within the limit, the selection is ok. Otherwise, the higher size (whose voltage drop suits the requirement) shall be selected. Following is an example for the above:

Example:

150 meters of three core cable, XLPE insulated, PVC sheathed, copper cable installed under ground to carry 100 amperes load, supply voltage 380 V.three phase system 50Hz, Ground temperature 40°C, soil thermal resistivity 2.5 k.m. / W and load factor 1.

Derating Factors:

*35mm² cable ampacity =176 amps
*Soil thermal resistivity = 0.71
*Ground temperature = 0.85

Therefore derated current = 106 Amps (176 x 0.71 x 0.85)

Voltage drop(Vap) = $\frac{V_p \times 1000 \times V}{I \times L \times 100}$ V/A/KM

VP = maximum permissible voltage drop (say2.5%)
V = System voltage (Here 380V)
L = Length in meters (Here 150 meter)
Therefore, Vap = $\frac{2.5 \times 1000 \times 380}{100 \times 150 \times 100}$ V/A/KM
= 0.633V/A/KM

From table on page 52 of this catalogue, the voltage drop of 35 mm²XLPE insulated multi core cable is 1.011 V/A/km, which is much higher than the requirement of 0.633 V/A/km. The voltage drop of 70 mm² cable is 0.556 V/A/km which is with in the limit. Therefore, the suitable size is 70 mm².

Note:

* Please refer to the Low Voltage Electrical Guide N.C.I Brochure for finding the Ampacity, Soil Thermal Resistivity and Ground Temperature.



Drum Handling Instruction

National Cable Industry Cables and Conductors should be installed by trained personnel in accordance with good engineering practices, recognized codes of practice, statutory local requirements, IEE wiring regulations and where relevant, in accordance with any specific instructions issued by the company. Cables are often supplied in heavy cable reels and handling these reels can constitute a safety hazard. In particular, dangers may arise during the removal of steel binding straps and during the removal of retaining battens and timbers which may expose projecting nails.

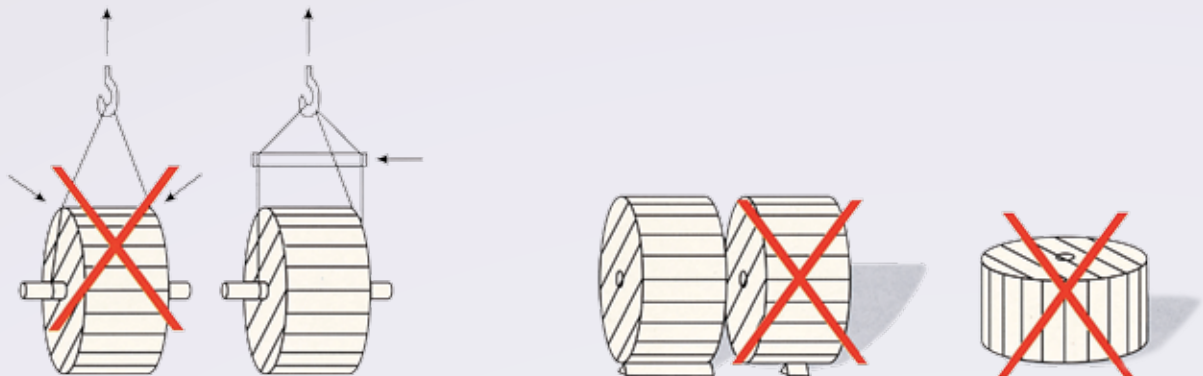



P.O. Box: 27472 Sharjah U.A.E.
Tel.: +971 6 5311888 (8 Lines) Fax.: +971 6 5311577
e-mail: n_c_i@emirates.net.ae website: www.nci.ae

NATIONAL
CABLES
INDUSTRY

NCI

الوطنية
لصناعة
الكابلات

Committed Quality for our Customers

*XLPE INSULATED
MEDIUM VOLTAGE CABLES*

INNOVATIVE
PROCESSES AND
TECHNOLOGY STRATEGIES

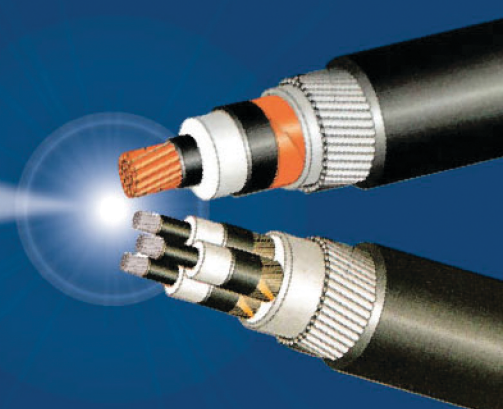

XLPE MATERIAL

The trend of cross-linked polyethylene insulated cables into power cables field is quite prevalent in the world as the substitutes of paper insulated cables, which had played the leading role in electric power transmission stage. Thus, nowadays after making its impact on its use in the medium voltage cable category, the stage seems to be turning in favour of XLPE cables in the high voltage and extra high voltage range. Especially in the higher voltage area, the monopoly of paper insulated cables, such as oil filled cable, gas filled and compressed type of cables, is gradually collapsing into the co-existence with XLPE cables, which have great advantages and economical reasons such as higher permissible temperature level, ease of jointing and maintenance techniques and omission of equivalent inherent to the pressurized cable.

Electrical performance of XLPE is excellent. Di-electric breakdown strength and volume resistivity are high and both Di-electric loss ($\tan \delta$) and dielectric constant (ϵ) are low. Thermal resistivity is low. XLPE insulated cables can operate continuously at a temperature of 90°C, because they have excellent heat ageing characteristics. This leads to large power transmission capacity. XLPE cables are lighter in weight, they are easy to handle and install and jointing and termination is also easy. They are of dry type because no oil impregnation is involved.

The insulation material for XLPE cables is low-density (LD) polyethylene. PE has for a long time had a wide use as cable insulating and sheath materials owing to its excellent electrical and mechanical properties, its lightness, low temperature flexibility and good resistance to moisture, chemicals, ozone etc. as well as its comparatively low price.

However, Low Density Polyethylene has properties which limit its use as cable insulation. Being a thermoplastic, its softening temperature is 105 - 115°C. Another disadvantage is its tendency to stress cracking when in contact with certain surface-active agents.

By means of a process reminiscent of the vulcanization of rubber, PE molecules can be cross-linked, thus greatly improving the thermal and mechanical properties of the material, while its electrical properties are retained largely unchanged. This product, cross-linked polyethylene (XLPE), is therefore no longer a thermoplastic. It assumes elastic, rubber-like consistency, a property that retains during further rise of temperature. The tendency to stress cracking entirely disappears and the material also acquires very good resistance to ageing in hot air.

CROSS-LINKED POLYETHYLENE

PE is made up of long molecular chains. By cross-linking, these chains a network of strong bonds is created and PE is converted into cross-linked polyethylene, XLPE.

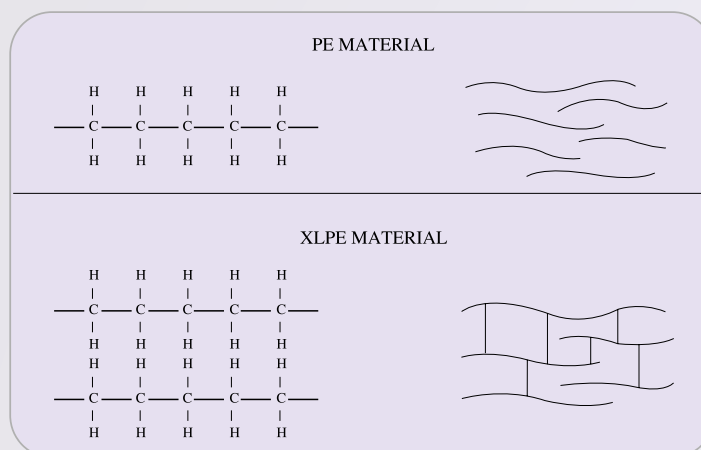

THERMAL PROPERTIES

Owing to the cross-linking, XLPE is a very heat-resistant material. It cannot melt like polyethylene but decomposes and carbonizes if exposed for long periods to temperature above 300°C.

The permissible conductor temperature during short-circuit for 1 second has therefore been put at 250°C and under continuous load, conductors with XLPE insulation may have a temperature of 90°C. These temperature are specified by International standards. In emergency conditions and for limited period, XLPE can withstand 130°C.

XLPE, like PE, retains its low temperature flexibility down to -40°C which implies great advantages during laying of cables.

ELECTRICAL PROPERTIES

The good electrical properties of PE remain largely unchanged during cross-linking process. XLPE therefore, like PE, has a very small and insignificant temperature dependant loss factor ($\tan \delta$) and dielectric constant (ϵ) As a result the dielectric loss of XLPE cables are small in comparison with those of PVC and paper insulated cables. XLPE cables are specially adapted for long cable routes and high voltages, in both cases where dielectric losses are of great significant.

MECHANICAL PROPERTIES

Polyethylene has good mechanical properties. It is interesting that at normal temperature PE can resist local stress better than PVC. In this respect XLPE has the same advantageous properties as PE and certain grades, such as filled XLPE insulation also resist abrasion much better than polyethylene.

CHEMICAL PROPERTIES

Owing to the cross-linking of molecules XLPE better resistance than PE to most chemical such as ordinary acids, bases and oil.

ENVIRONMENTAL POLLUTION AND CABLES

From the environmental aspect, both PVC and oil-impregnated paper-insulated cables have distinct disadvantages. When PVC cables burn they give off corrosive gases, and a leaking oil filled cable may cause severe damage to environment.

XLPE admittedly burns, but the products of combustion carbon dioxide and water do not cause damage. Filled XLPE used for low voltage cables can also be made resistant to flame propagation and the compound does not produce halogen.



CROSS-LINKING PROCESS

Cross-linking is done by agent Di-Cumyl Peroxide (DCP). Cross-linking takes place in the CCV Tube under heated and pressurized Nitrogen where DCP decomposes into two radicals, which react with Polyethylene, thereby causing cross-linking.

Peroxide is already mixed at the material supplier's plant with proper balance of anti-oxidant and peroxide to ensure the required thermal stability and optimum curing level. Therefore, no mixing is done during production. This prevents problems which might occur due to the unbalance mixing of material during production stage. Un-packing and handling of the material is also done in similar super clean environment.

The mixing ratio is about 1 to 1.5 PHR with very small amount of anti-oxidant. The cross-link residue is gas, which defuses out of the insulation gradually. Other residuals are Acetophone and Cumyl-alcohol which are in very low ratio. Research, in this regard, has proven that these materials have very good effect on insulation such as:

- a) It improves the breaking strength when inclusion occurs in XLPE material.
- b) It slows water tree growth in the XLPE material under service.

National Cables Industry employs in-line dry curing for all its CCV lines along with state-of-the-art Triple Cross-Head extrusion where the Conductor Screen, Insulation and Insulation Screen are extruded simultaneously by means of a Triple Cross Head which has the following advantages:

- Reduce micro voids and moisture content in insulation and ensures enhanced and stable breakdown strength and uniform insulation structure.
- Ensures extremely accurate layer thickness.
- Ensures high purity in the frontier limit between the semi-conductive layers and the insulation.
- Provides optimal fusion of the individual layers without contamination.
- Ensures a firm bond and smooth interface between each layer improving electrical properties.
- Prevents unforeseen damage to the conductor or insulation screen during manufacturing process.

The above are optimized by the use of an X-Ray unit located immediately after the cross-head which provides a transparent view of all three layers. This arrangement also facilitates recording the trend every 4 seconds. The unit continuously scans 360° geometry of the cable and displays the maximum, minimum and eccentricity of all three layers separately. Any deviation between the specified values and the measured values are recorded and adjusted automatically.

Also incorporated in the CCV line is the "Twin-Rot" system, one of the latest in manufacturing technology, which ensures superior control of eccentricity and eliminates the possibility of "Pear Drop" since the cable rotates during manufacture.



QUALITY ASPECT

It is the policy of National Cables Industry to supply customers with products meeting fully their stated needs. The products perform their required functions safely, consistently and reliably of their intended use. They fully meet the specifications which they are designed to meet whether Customer, Country or International.

NCI sources its raw materials from reputed suppliers from all over the world. The most important cable constituents such as XLPE material, conductor and insulation shielding material are procured from the world's leading suppliers of cable components. Right from the beginning, all incoming material and cable constituents are analyzed and tested to ensure their quality and compliance with specifications before being used. During manufacture, again complete tests are performed on physical, mechanical and electrical properties of insulation and sheath material.

NCI products are also type tested at International agencies. Several of the products are type tested and certified from KEMA, Netherlands, IPH, Berlin, Germany and CPRI, India. Type tests are also performed in-house on a pre-defined regular basis to ensure and guarantee the quality of the manufactured products.

Testing facilities are equipped with up-to-date most modern and advanced laboratories. The laboratories are equipped with facilities for complete testing of its products both for incoming raw materials as well as finished goods as per International Standards. Test fields include routine test field with large shielded enclosures for carrying out the routine high voltage tests, Partial discharge measurement up to 250kV at a noise level of below 2 pC, measurement of $(\tan \delta)$, capacitance and 900kV impulse generator.



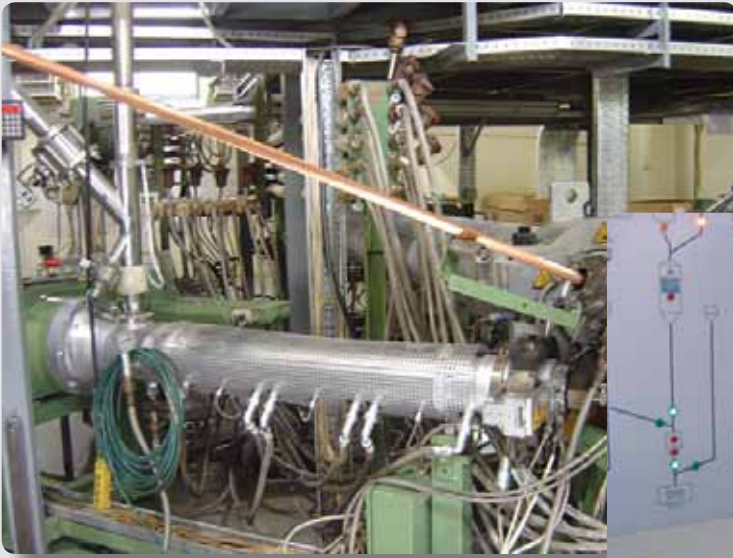

CCV Line



MV Test Field



Material Testing Laboratory



The table below shows some typical properties of XLPE material, PVC, EP Rubber and Impregnated Paper

	XLPE		PVC	EP Rubber	Impregnated Paper
	Unfilled	Filled			
Dielectric constant @ 20°C	2.30	4	5	3	3.5
Loss factor, @ 50-60Hz, 20°C	0.0005	0.0005	0.07	0.003	0.003
Volume resistivity @ 20°C, Ω.cm	10 ¹⁶	10 ¹⁴	10 ¹²	10 ¹⁶	10 ¹³
Max. Continuous operating Temperature, °C	90	90	70	85	65
Max. conductor temperature at Short-circuit current °C	250	250	160	250	150
Tensile Strength N/mm ²	15	15	15	5	-
Elongation at rupture, %	500	300	250	300	-
Flexibility					
20 °C	Good	Good	Excellent	Excellent	-
-10 °C	Good	Good	Poor	Excellent	-
Abrasion resistance	Good	Excellent	Good	Poor	-
Deformation resistance @ 150 °C	Good	Excellent	Poor	Excellent	Good
Oil resistance at 70 °C	Good	Good	Good	Poor	-
Fire resistance	Poor	Moderate	Excellent	Poor	Poor
Ageing resistance at					
100 °C	Excellent	Excellent	Moderate	Good	Good
120 °C	Good	Good	Poor	Moderate	Moderate
150 °C	Moderate	Moderate	-	Poor	Poor

*Filled XLPE is used for 0.6/1kV cables.



CONDUCTORS

Conductors shall be stranded class 2 of plain annealed copper or aluminium and in accordance with IEC 60228 and BS EN 60228 (earlier BS 6360).

CONDUCTOR SCREEN

Conductor screen shall be non-metallic and shall consist of an extruded semi-conductive compound which may be applied on top of a semi-conductive tape at the manufacturer's discretion. The extruded semi-conducting compound shall be firmly bonded to the insulation.

XLPE INSULATION

Insulation shall be XLPE (cross-linked polyethylene). Thickness and test requirements shall comply with IEC 60502-2 and IEC 60811 series.

INSULATION SCREEN

The insulation screen shall consist of a non-metallic semi-conducting layer in combination with a metallic layer.

Non-metallic part: The non-metallic layer shall be extruded directly upon the insulation of each core and shall consist of either a strippable or bonded semi-conducting compound.

Metallic part: Metallic layer shall consist of one or more tapes or a concentric layer of wires or a combination of wire and tapes.

INNER COVERING/SEPARATION SHEATH

Inner covering may be extruded or lapped. When the underlying metallic layer and the armour are of different materials, they shall be separated by an extruded sheath of PVC or Polyethylene or LSF as applicable.

METALLIC ARMOUR

Armour shall be as per IEC 60502-2 of the following types:

- a) Round Wire Armour
- b) Double Tape Armour

Armour material shall be Galvanized Steel for three core cables and Aluminium for single core cables.

OUTER SHEATH

Outer sheath shall be extruded PVC type ST2 as per IEC 60502-2, Type 9 as per BS 7655. Special type of PVC sheathing materials such as Fire Retardant PVC, anti-termite and anti-rodent PVC, Ultraviolet PVC, Oil Resistant PVC, etc. are available on request. Also, other special sheathing materials such as LLDPE, MDPE, HDPE, LSF etc are available.

PHASE IDENTIFICATION

For 3 core cables, Red, Yellow and Blue coloured strips shall be applied under the metallic screen throughout the length of the cable for phase identification.

For single core cables no phase identification shall be provided.



UNARMoured SINGLE CORE CABLES

COPPER CONDUCTORS

IEC 60502-2
and BS 6622

U_o/U (U_m)=3.6/6(7.2) kV
3.8/6.6(7.2) kV

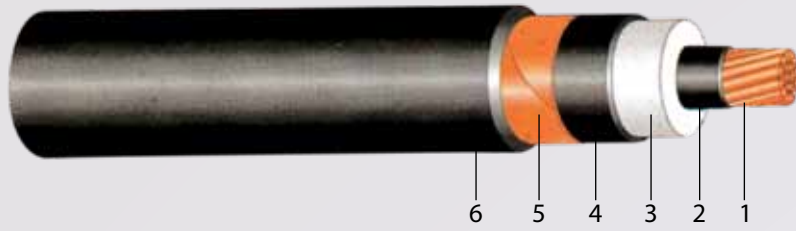

1. Conductor
2. Conductor Screen
3. XLPE Insulation
4. Insulation Screen (Non-metallic)
5. Insulation Screen (Metallic)
6. Outer Sheath

Size	Diameter of Conductor (Approx.)	Nominal Insulation Thickness	Diameter Over Insulation (Approx.)	Nominal Outer Sheath Thickness		Overall Diameter (Approx.)		Weight of Cable (Approx.)	
				CUT	CUW	CUT	CUW	CUT	CUW
mm ²	mm	mm	mm	mm	mm	mm	mm	Kg/km	Kg/km
25	5.9	2.5	12.5	1.8	1.5	18	20	510	725
35	6.9	2.5	13.5	1.8	1.6	19	21	650	825
50	8.1	2.5	14.7	1.6	1.6	21	22	785	950
70	9.7	2.5	16.3	1.6	1.6	22	24	1010	1175
95	11.4	2.5	18.0	1.7	1.7	24	25	1300	1475
120	12.9	2.5	19.5	1.7	1.8	26	26	1550	1750
150	14.3	2.5	20.9	1.8	1.8	27	28	1825	2100
185	16.0	2.5	22.6	1.8	1.9	29	30	2200	2400
240	18.4	2.6	25.2	1.9	1.9	32	33	2800	3000
300	20.4	2.8	27.6	2.0	2.0	34	36	3400	3600
400	23.2	3.0	30.8	2.1	2.2	38	39	4275	4675
500	26.7	3.2	34.7	2.2	2.3	42	44	5375	5800
630	30.4	3.2	38.4	2.3	2.4	46	48	6800	7075

Size	Max DC Resistance @ 20°C	Inductance		Capacitance	Conductor Short Circuit Current for 1 second	Current ratings						Voltage drop per phase	
		Trefoil	Flat			Buried Direct In the ground		In single-way ducts		In air			
						Trefoil	Flat Spaced	Trefoil ducts	Flat Touching ducts	Trefoil	Flat Touching		Flat Spaced
mm ²	Ohm/km	mH/km	mH/km	μF/km	kA	Amps	Amps	Amps	Amps	Amps	Amps	Amps	V/A. Km
25	0.727	0.444	0.760	0.26	3.575	140	144	132	133	163	167	196	0.825
35	0.524	0.426	0.745	0.29	5.005	166	172	157	159	198	203	238	0.615
50	0.387	0.408	0.720	0.32	7.150	196	203	186	188	238	243	286	0.472
70	0.268	0.388	0.694	0.37	10.010	239	246	227	229	296	303	356	0.347
95	0.193	0.378	0.679	0.39	13.585	285	293	271	274	361	369	434	0.269
120	0.153	0.364	0.660	0.44	17.160	323	332	308	311	417	426	500	0.225
150	0.124	0.354	0.645	0.48	21.450	361	366	343	347	473	481	559	0.194
185	0.0991	0.343	0.630	0.52	26.455	406	410	387	391	543	550	637	0.167
240	0.0754	0.332	0.611	0.56	34.320	469	470	447	453	641	647	745	0.141
300	0.0601	0.324	0.596	0.58	42.900	526	524	504	510	735	739	846	0.125
400	0.0470	0.313	0.578	0.61	57.200	590	572	564	574	845	837	938	0.110
500	0.0366	0.306	0.564	0.64	71.500	655	625	635	640	956	935	1028	0.099
630	0.0283	0.296	0.548	0.71	90.090	731	690	712	720	1095	1061	1158	0.09

Laying condition: Maximum conductor temperature 90°C, Ambient temperature 30°C. Underground temperature of soil 20°C, Depth of laying - 0.8m. Ground thermal resistivity 1.5 K.m/W, thermal resistivity of earthenware ducts 1.2 K.m/W.

Note: Area of copper wire considered is 16 mm² up to 120 mm², 25 mm² from 150 mm² up to 300 mm², 35 mm² from 400 mm² up to 630 mm².

UNARMoured SINGLE CORE CABLES

COPPER CONDUCTORS

IEC 60502-2
and BS 6622

U₀/U (U_m)=6/10(12) kV
6.35/11(12) kV

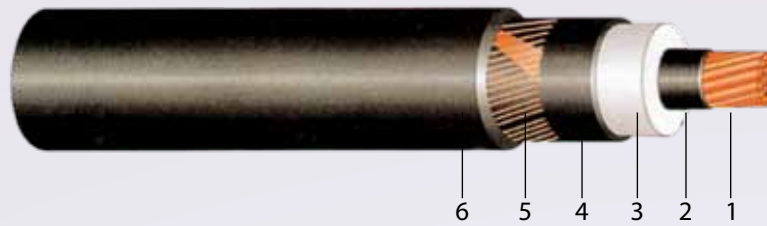

1. Conductor
2. Conductor Screen
3. XLPE Insulation
4. Insulation Screen (Non-metallic)
5. Insulation Screen (Metallic)
6. Outer Sheath

Size	Diameter of Conductor (Approx.)	Nominal Insulation Thickness	Diameter Over Insulation (Approx.)	Nominal Outer Sheath Thickness		Overall Diameter (Approx.)		Weight of Cable (Approx)	
				CUT	CUW	CUT	CUW	CUT	CUW
mm ²	mm	mm	mm	mm	mm	mm	mm	Kg/km	Kg/km
25	5.9	3.4	14.3	1.8	1.8	20	22	600	775
35	6.9	3.4	15.3	1.8	1.8	21	23	700	875
50	8.1	3.4	16.5	1.8	1.8	22	24	850	990
70	9.7	3.4	18.1	1.8	1.8	24	26	1075	1200
95	11.4	3.4	19.8	1.8	1.8	26	27	1350	1500
120	12.9	3.4	21.3	1.8	1.8	27	29	1625	1725
150	14.3	3.4	22.7	1.8	1.9	29	30	1900	2100
185	16.0	3.4	24.4	1.9	1.9	31	32	2300	2475
240	18.4	3.4	26.8	2.0	2.0	33	35	2900	3100
300	20.4	3.4	28.8	2.0	2.1	35	37	3475	3700
400	23.2	3.4	31.6	2.1	2.2	38	40	4325	4650
500	26.7	3.4	35.1	2.2	2.3	42	44	5400	5725
630	30.4	3.4	38.8	2.3	2.4	46	48	6825	7100

Size	Max DC Resistance @ 20°C	Inductance		Capacitance	Conductor Short Circuit Current for 1 second	Current ratings							Voltage drop per phase	
		Trefoil	Flat			Buried Direct In the ground		In single-way ducts		In air				
						Trefoil	Flat Spaced	Trefoil ducts	Flat Touching ducts	Trefoil	Flat Touching	Flat Spaced		
mm ²	Ohm/km	mH/km	mH/km	µF/km	kA	Amps	Amps	Amps	Amps	Amps	Amps	Amps	Amps	V/A. Km
25	0.727	0.460	0.770	0.21	3.575	140	144	132	133	163	167	196	0.829	
35	0.524	0.440	0.751	0.23	5.005	166	172	157	159	198	203	238	0.618	
50	0.387	0.420	0.726	0.25	7.150	196	203	186	188	238	243	286	0.474	
70	0.268	0.401	0.700	0.29	10.010	239	246	227	229	296	303	356	0.349	
95	0.193	0.383	0.681	0.31	13.585	285	293	271	274	361	369	434	0.270	
120	0.153	0.376	0.666	0.34	17.160	323	332	308	311	417	426	500	0.228	
150	0.124	0.364	0.650	0.37	21.450	361	366	343	347	473	481	559	0.196	
185	0.0991	0.354	0.635	0.40	26.455	406	410	387	391	543	550	637	0.169	
240	0.0754	0.341	0.615	0.45	34.320	469	470	447	453	641	647	745	0.143	
300	0.0601	0.329	0.593	0.49	42.900	526	524	504	510	735	739	846	0.126	
400	0.0470	0.318	0.580	0.55	57.200	590	572	564	571	845	837	938	0.111	
500	0.0366	0.308	0.565	0.60	71.500	655	625	635	640	956	935	1028	0.100	
630	0.0283	0.299	0.549	0.68	90.090	731	690	712	720	1095	1061	1158	0.091	

Laying condition: Maximum conductor temperature 90°C, Ambient temperature 30°C. Underground temperature of soil 20°C, Depth of laying - 0.8m. Ground thermal resistivity 1.5 K.m/W, thermal resistivity of earthenware ducts 1.2 K.m/W.

Note: Area of copper wire considered is 16 mm² up to 120 mm², 25 mm² from 150 mm² up to 300 mm², 35 mm² from 400 mm² up to 630 mm².



UNARMoured SINGLE CORE CABLES

COPPER CONDUCTORS

IEC 60502-2
and BS 6622

U₀/U (U_m)=8.7/15(17.5) kV

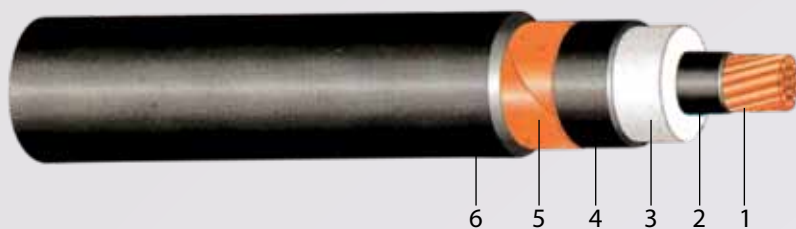

1. Conductor
2. Conductor Screen
3. XLPE Insulation
4. Insulation Screen (Non-metallic)
5. Insulation Screen (Metallic)
6. Outer Sheath

Size	Diameter of Conductor (Approx.)	Nominal Insulation Thickness	Diameter Over Insulation (Approx.)	Nominal Outer Sheath Thickness		Overall Diameter (Approx.)		Weight of Cable (Approx)	
				CUT	CUW	CUT	CUW	CUT	CUW
mm ²	mm	mm	mm	mm	mm	mm	mm	Kg/km	Kg/km
25	5.9	4.5	16.5	1.8	1.8	22	24	675	850
35	6.9	4.5	17.5	1.8	1.8	23	25	800	925
50	8.1	4.5	18.7	1.8	1.8	25	26	950	1075
70	9.7	4.5	20.3	1.8	1.8	26	28	1175	1300
95	11.4	4.5	22.0	1.8	1.8	28	30	1425	1575
120	12.9	4.5	23.5	1.9	1.9	30	31	1750	1850
150	14.3	4.5	24.9	1.9	1.9	31	33	2025	2225
185	16.0	4.5	26.6	2.0	2.0	33	35	2425	2625
240	18.4	4.5	29.0	2.0	2.1	35	37	3000	3225
300	20.4	4.5	31.0	2.1	2.1	38	39	3650	3825
400	23.2	4.5	33.8	2.2	2.3	41	42	4475	4800
500	26.7	4.5	37.3	2.3	2.4	44	46	5575	5900
630	30.4	4.5	41.0	2.4	2.5	49	51	7075	7375

Size	Max DC Resistance @ 20°C	Inductance		Capacitance	Conductor Short Circuit Current for 1 second	Current ratings						Voltage drop per phase	
		Trefoil	Flat			Buried Direct In the ground		In single-way ducts		In air			
						Trefoil	Flat Spaced	Trefoil ducts	Flat Touching ducts	Trefoil	Flat Touching		Flat Spaced
mm ²	Ohm/km	mH/km	mH/km	µF/km	kA	Amps	Amps	Amps	Amps	Amps	Amps	Amps	V/A.Km
25	0.727	0.470	0.780	0.17	0.456	140	144	132	133	163	167	196	0.830
35	0.524	0.758	0.19	0.435	0.732	166	172	157	159	198	203	238	0.621
50	0.387	0.21	0.415	0.706	0.23	196	203	186	188	238	243	286	0.477
70	0.268	0.402	0.690	0.25	0.389	239	246	227	229	296	303	356	0.352
95	0.193	0.672	0.27	0.377	0.656	285	293	271	274	361	369	434	0.273
120	0.153	0.29	0.366	0.641	0.32	323	332	308	311	417	426	500	0.230
150	0.124	0.352	0.621	0.35	0.340	361	366	343	347	473	481	559	0.198
185	0.0991	0.605	0.39	0.327	0.585	406	410	387	391	543	550	637	0.172
240	0.0754	0.43	0.318	0.570	0.48	469	470	447	453	641	647	745	0.146
300	0.0601	0.307	0.554	0.53	0.830	526	524	504	510	735	739	846	0.128
400	0.0470	0.621	0.477	0.352	0.273	590	572	564	571	845	837	938	0.113
500	0.0366	0.470	0.780	0.17	0.456	655	625	635	640	956	935	1028	0.102
630	0.0283	0.758	0.19	0.435	0.732	731	690	712	720	1095	1061	1158	0.092

Laying condition: Maximum conductor temperature 90°C, Ambient temperature 30°C. Underground temperature of soil 20°C, Depth of laying - 0.8m. Ground thermal resistivity 1.5 K.m/W, thermal resistivity of earthenware ducts 1.2 K.m/W.

Note: Area of copper wire considered is 16 mm² up to 120 mm², 25 mm² from 150 mm² up to 300 mm², 35 mm² from 400 mm² up to 630 mm².



UNARMoured SINGLE CORE CABLES

COPPER CONDUCTORS

IEC 60502-2
and BS 6622

U₀/U (U_m)=12/20(24) kV
12.7/22(24) kV

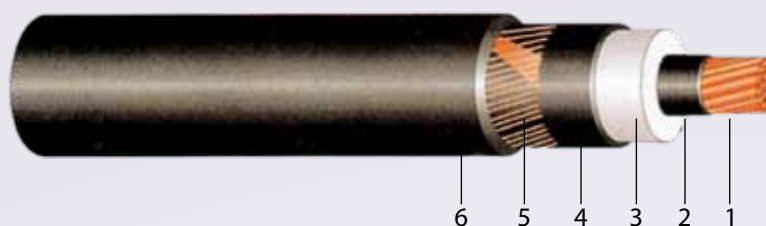

1. Conductor
2. Conductor Screen
3. XLPE Insulation
4. Insulation Screen (Non-metallic)
5. Insulation Screen (Metallic)
6. Outer Sheath

Size	Diameter of Conductor (Approx.)	Nominal Insulation Thickness	Diameter Over Insulation (Approx.)	Nominal Outer Sheath Thickness		Overall Diameter (Approx.)		Weight of Cable (Approx)	
				CUT	CUW	CUT	CUW	CUT	CUW
mm ²	mm	mm	mm	mm	mm	mm	mm	Kg/km	Kg/km
25	5.9	6.0	19.5	1.8	1.8	25	27	800	925
35	6.9	5.5	19.5	1.8	1.8	25	27	875	1000
50	8.1	5.5	20.7	1.8	1.8	27	28	1050	1150
70	9.7	5.5	22.3	1.8	1.9	28	30	1275	1400
95	11.4	5.5	24.0	1.9	1.9	30	31	1575	1675
120	12.9	5.5	25.5	1.9	2.0	32	33	1850	2000
150	14.3	5.5	26.9	2.0	2.0	33	35	2150	2350
185	16.0	5.5	28.6	2.0	2.1	35	37	2550	2750
240	18.4	5.5	31.0	2.1	2.1	38	39	3150	3350
300	20.4	5.5	33.0	2.2	2.2	40	41	3775	3975
400	23.2	5.5	35.8	2.3	2.3	43	44	4650	4925
500	26.7	5.5	39.3	2.4	2.4	49	49	5800	6100
630	30.4	5.5	43.0	2.5	2.5	51	53	7250	7525

Size	Max DC Resistance @ 20°C	Inductance		Capacitance	Conductor Short Circuit Current for 1 second	Current ratings							Voltage drop per phase
		Trefoil	Flat			Buried Direct In the ground	In single -way ducts		In air				
							Trefoil	Flat Spaced	Trefoil ducts	Flat Touching ducts	Trefoil	Flat Touching	
mm ²	Ohm/km	mH/km	mH/km	µF/km	kA	Amps	Amps	Amps	Amps	Amps	Amps	Amps	V/A. Km
25	0.727	0.497	0.792	0.14	3.575	140	144	132	133	163	167	196	0.835
35	0.524	0.468	0.763	0.16	5.005	166	172	157	159	198	203	238	0.623
50	0.387	0.448	0.738	0.18	7.150	196	203	186	188	238	243	286	0.480
70	0.268	0.426	0.712	0.20	10.010	239	246	227	229	296	303	356	0.354
95	0.193	0.414	0.696	0.21	13.585	285	293	271	274	361	369	434	0.276
120	0.153	0.399	0.677	0.23	17.160	323	332	308	311	417	426	500	0.232
150	0.124	0.388	0.662	0.25	21.450	361	366	343	347	473	481	559	0.201
185	0.0991	0.375	0.646	0.27	26.455	406	410	387	391	543	550	637	0.173
240	0.0754	0.361	0.626	0.30	34.320	469	470	447	453	641	647	745	0.147
300	0.0601	0.350	0.610	0.33	42.900	526	524	504	510	735	739	846	0.130
400	0.0470	0.336	0.590	0.37	57.200	590	572	564	571	845	837	938	0.115
500	0.0366	0.326	0.575	0.40	71.500	655	625	635	640	956	935	1028	0.103
630	0.0283	0.315	0.558	0.45	90.090	731	690	712	720	1095	1061	1158	0.094

Laying condition: Maximum conductor temperature 90°C, Ambient temperature 30°C. Underground temperature of soil 20°C, Depth of laying -0.8m. Ground thermal resistivity 1.5 K.m/W, thermal resistivity of earthenware ducts 1.2 K.m/W.

Note: Area of copper wire considered is 16 mm² up to 120 mm², 25 mm² from 150 mm² up to 300 mm², 35 mm² from 400 mm² up to 630 mm².



UNARMoured SINGLE CORE CABLES

COPPER CONDUCTORS

IEC 60502-2
and BS 6622

$U_0/U (U_m)=18/30(36) \text{ kV}$
 $19/33(36) \text{ kV}$

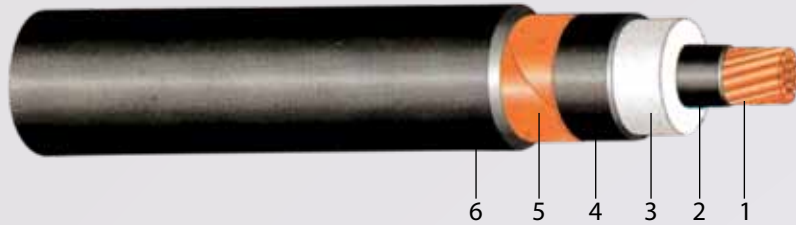

- 1. Conductor
- 2. Conductor Screen
- 3. XLPE Insulation
- 4. Insulation Screen (Non-metallic)
- 5. Insulation Screen (Metallic)
- 6. Outer Sheath

Size	Diameter of Conductor (Approx.)	Nominal Insulation Thickness	Diameter Over Insulation (Approx.)	Nominal Outer Sheath Thickness		Overall Diameter (Approx.)		Weight of Cable (Approx.)	
				CUT	CUW	CUT	CUW	CUT	CUW
mm ²	mm	mm	mm	mm	mm	mm	mm	Kg/km	Kg/km
50	8.1	8.0	25.7	1.9	2.0	32	33	1300	1500
70	9.7	8.0	27.3	2.0	2.0	34	35	1575	1700
95	11.4	8.0	29.0	2	2.1	36	37	1900	2000
120	12.9	8.0	30.5	2.1	2.1	37	38	2150	2275
150	14.3	8.0	31.9	2.1	2.2	38	40	2450	2675
185	16.0	8.0	33.6	2.2	2.2	40	42	2900	3075
240	18.4	8.0	36.0	2.3	2.3	43	44	3525	3700
300	20.4	8.0	38.0	2.3	2.4	45	47	4150	4350
400	23.2	8.0	40.8	2.5	2.5	49	50	5050	5400
500	26.7	8.0	44.3	2.5	2.6	52	54	6150	6525
630	30.4	8.0	48.0	2.7	2.7	56	57	7650	8000

Size	Max DC Resistance @ 20°C	Inductance		Capacitance	Conductor Short Circuit Current for 1 second	Current ratings							Voltage drop per phase
		Trefoil	Flat			Buried Direct In the ground	In single-way ducts		In air				
							Trefoil	Flat Spaced	Trefoil ducts	Flat Touching ducts	Trefoil	Flat Touching	
mm ²	Ohm/km	mH/km	mH/km	µF/km	kA	Amps	Amps	Amps	Amps	Amps	Amps	Amps	V/A.Km
50	0.387	0.482	0.755	0.14	7.150	196	203	186	188	238	243	286	0.486
70	0.268	0.457	0.728	0.16	10.010	239	246	227	229	296	303	356	0.36
95	0.193	0.446	0.712	0.17	13.585	285	293	271	274	361	369	434	0.282
120	0.153	0.430	0.693	0.18	17.160	323	332	308	311	417	426	500	0.238
150	0.124	0.417	0.677	0.19	21.450	361	366	343	347	473	481	559	0.206
185	0.0991	0.404	0.661	0.21	26.455	406	410	387	391	543	550	637	0.179
240	0.0754	0.388	0.641	0.23	34.320	469	470	447	453	641	647	745	0.152
300	0.0601	0.375	0.624	0.25	42.900	526	524	504	510	735	739	846	0.135
400	0.0470	0.360	0.604	0.27	57.200	590	572	564	571	845	837	938	0.119
500	0.0366	0.349	0.589	0.30	71.500	655	625	635	640	956	935	1028	0.108
630	0.0283	0.388	0.570	0.33	90.090	731	690	712	720	1095	1061	1158	0.098

Laying condition: Maximum conductor temperature 90°C, Ambient temperature 30°C. Underground temperature of soil 20°C, Depth of laying - 0.8m. Ground thermal resistivity 1.5 K.m/W, thermal resistivity of earthenware ducts 1.2 K.m/W.

Note: Area of copper wire considered is 16 mm² up to 120 mm², 25 mm² from 150 mm² up to 300 mm², 35 mm² from 400 mm² up to 630 mm².



ARMoured SINGLE CORE CABLES

COPPER CONDUCTORS

IEC 60502-2
and BS 6622

U_o/U (U_m)=3.6/6(7.2) kV
3.8/6.6(7.2) kV

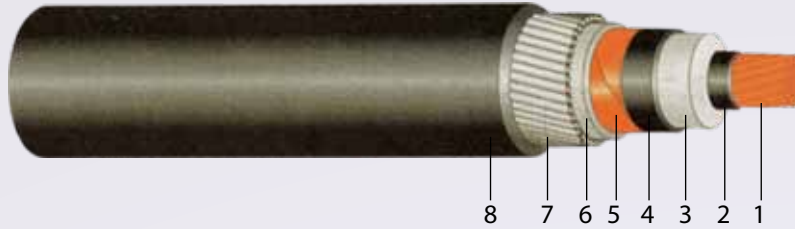

1. Conductor
2. Conductor Screen
3. XLPE Insulation
4. Insulation Screen (Non-metallic)
5. Insulation Screen (Metallic)
6. Bedding
7. Aluminium Wire Armour
8. Outer Sheath

Size	Diameter of Conductor (Approx.)	Nominal Insulation Thickness	Diameter Over Insulation (Approx.)	Nominal Diameter of Aluminium Wire		Nominal Outer Sheath Thickness		Overall Diameter (Approx.)		Weight of Cable (Approx)	
				CUT/CUW	CUT	CUW	CUT	CUW	CUT	CUW	CUT
mm ²	mm	mm	mm	mm	mm	mm	mm	mm	mm	Kg/km	Kg/km
25	5.9	2.5	12.5	1.6	1.8	1.8	24	26	875	1075	
35	6.9	2.5	13.5	1.6	1.8	1.8	25	27	1000	1175	
50	8.1	2.5	14.7	1.6	1.8	1.8	27	28	1150	1350	
70	9.7	2.5	16.3	1.6	1.8	1.8	28	30	1400	1600	
95	11.4	2.5	18.0	1.6	1.9	1.9	30	32	1750	1950	
120	12.9	2.5	19.5	1.6	1.9	1.9	32	33	1975	2200	
150	14.3	2.5	20.9	1.6/2.0	2.0	2.0	33	35	2300	2675	
185	16.0	2.5	22.6	2.0	2.0	2.0	36	37	2750	3100	
240	18.4	2.6	25.2	2.0	2.1	2.2	39	40	3450	3800	
300	20.4	2.8	27.6	2.0	2.2	2.2	41	43	4175	4475	
400	23.2	3.0	30.8	2.0/2.5	2.3	2.4	45	48	5100	5725	
500	26.7	3.2	34.7	2.5	2.5	2.5	50	52	6500	6900	
630	30.4	3.2	38.4	2.5	2.6	2.6	54	56	8050	8475	

Size	Max DC Resistance @ 20°C	Inductance			Capacitance	Conductor Short Circuit Current for 1 second	Current ratings						Voltage drop per phase
		Trefoil	Flat	Buried Direct In the ground			In single-way ducts		In air				
							Trefoil ducts	Flat Touching ducts	Trefoil	Flat Touching	Flat Spaced		
mm ²	Ohm/km	mH/km	mH/km	µF/km	kA	Amps	Amps	Amps	Amps	Amps	Amps	Amps	V/A.Km
25	0.727	0.473	0.785	0.26	3.575	137	142	131	133	162	165	189	0.831
35	0.524	0.461	0.760	0.29	5.005	164	168	155	158	196	199	228	0.622
50	0.387	0.440	0.735	0.32	7.150	193	197	183	186	234	238	271	0.478
70	0.268	0.418	0.708	0.37	10.010	234	238	223	226	291	294	334	0.352
95	0.193	0.406	0.792	0.39	13.585	278	280	265	268	353	355	401	0.274
120	0.153	0.392	0.673	0.44	17.160	315	313	301	303	406	407	455	0.231
150	0.124	0.380	0.658	0.48	21.450	349	340	334	335	460	454	501	0.199
185	0.0991	0.369	0.642	0.52	26.455	391	374	376	375	524	513	559	0.172
240	0.0754	0.356	0.623	0.56	34.320	446	416	430	425	611	589	633	0.146
300	0.0601	0.346	0.608	0.58	42.900	495	451	478	471	692	657	697	0.129
400	0.0470	0.334	0.589	0.61	57.200	551	488	534	522	788	733	764	0.114
500	0.0366	0.327	0.576	0.64	71.500	593	509	578	555	873	786	815	0.103
630	0.0283	0.315	0.558	0.71	90.090	646	542	632	604	975	858	882	0.094

Laying condition: Maximum conductor temperature 90°C, Ambient temperature 30°C. Underground temperature of soil 20°C, Depth of laying - 0.8m. Ground thermal resistivity 1.5 K.m/W, thermal resistivity of earthenware ducts 1.2 K.m/W.

Note: Area of copper wire considered is 16 mm² up to 120 mm², 25 mm² from 150 mm² up to 300 mm², 35 mm² from 400 mm² up to 630 mm².



ARMOURED SINGLE CORE CABLES

COPPER CONDUCTORS

IEC 60502-2
and BS 6622

$U_0/U (U_m)=6 /10(12) \text{ kV}$
 $6.35/11(12) \text{ kV}$



1. Conductor
2. Conductor Screen
3. XLPE Insulation
4. Insulation Screen (Non-metallic)
5. Insulation Screen (Metallic)
6. Bedding
7. Aluminium Wire Armour
8. Outer Sheath

Size	Diameter of Conductor (Approx.)	Nominal Insulation Thickness	Diameter Over Insulation (Approx.)	Nominal Diameter of Aluminium Wire		Nominal Outer Sheath Thickness		Overall Diameter (Approx.)		Weight of Cable (Approx.)	
				CUT/CUW	CUT	CUW	CUT	CUW	CUT	CUW	
mm ²	mm	mm	mm	mm	mm	mm	mm	mm	mm	Kg/km	Kg/km
25	5.9	3.4	14.3	1.6	1.8	1.8	26	27	950	1200	
35	6.9	3.4	15.3	1.6	1.8	1.8	27	28	1075	1325	
50	8.1	3.4	16.5	1.6	1.8	1.9	28	30	1275	1500	
70	9.7	3.4	18.1	1.6	1.9	1.9	30	31	1500	1750	
95	11.4	3.4	19.8	1.6	1.9	2.0	32	33	1850	2050	
120	12.9	3.4	21.3	1.6/2.0	2.0	2.0	33	35	2150	2450	
150	14.3	3.4	22.7	2.0	2	2.1	36	37	2575	2825	
185	16.0	3.4	24.4	2.0	2.1	2.1	37	39	2925	3225	
240	18.4	3.4	26.8	2.0	2.2	2.2	40	41	3625	3925	
300	20.4	3.4	28.8	2.0	2.2	2.3	42	44	4250	4575	
400	23.2	3.4	31.6	2.0/2.5	2.4	2.4	45	48	5175	5775	
500	26.7	3.4	35.1	2.5	2.5	2.5	50	52	6525	6950	
630	30.4	3.4	38.8	2.5	2.6	2.7	54	57	8050	8575	

Size	Max DC Resistance @ 20°C	Inductance		Capacitance	Conductor Short Circuit Current for 1 second	Current ratings							Voltage drop per phase	
		Trefoil	Flat			Buried Direct In the ground	In single-way ducts		In air					
							Trefoil	Flat Spaced	Trefoil ducts	Flat Touching ducts	Trefoil	Flat Touching		Flat Spaced
mm ²	Ohm/km	mH/km	mH/km	µF/km	kA	Amps	Amps	Amps	Amps	Amps	Amps	Amps	Amps	V/A. Km
25	0.727	0.488	0.790	0.21	3.575	137	142	131	133	162	165	189	0.833	
35	0.524	0.472	0.765	0.23	5.005	164	168	155	158	196	199	228	0.624	
50	0.387	0.450	0.739	0.25	7.150	193	197	183	186	234	238	271	0.48	
70	0.268	0.428	0.713	0.29	10.010	234	238	223	226	291	294	334	0.354	
95	0.193	0.416	0.697	0.31	13.585	278	280	265	268	353	355	401	0.276	
120	0.153	0.401	0.678	0.34	17.160	315	313	301	303	406	407	455	0.233	
150	0.124	0.390	0.663	0.37	21.450	349	340	334	335	460	454	501	0.201	
185	0.0991	0.378	0.647	0.40	26.455	391	374	376	375	524	513	559	0.174	
240	0.0754	0.363	0.627	0.45	34.320	446	416	430	425	611	589	633	0.147	
300	0.0601	0.351	0.611	0.49	42.900	495	451	478	471	692	657	697	0.130	
400	0.0470	0.338	0.591	0.55	57.200	551	488	534	522	788	733	764	0.115	
500	0.0366	0.328	0.576	0.60	71.500	593	509	578	555	873	786	815	0.103	
630	0.0283	0.317	0.560	0.68	90.090	646	542	632	604	975	858	882	0.094	

Laying condition: Maximum conductor temperature 90°C, Ambient temperature 30°C. Underground temperature of soil 20°C, Depth of laying - 0.8m. Ground thermal resistivity 1.5 K.m/W, thermal resistivity of earthenware ducts 1.2 K.m/W.

Note: Area of copper wire considered is 16 mm² up to 120 mm², 25 mm² from 150 mm² up to 300 mm², 35 mm² from 400 mm² up to 630 mm².



ARMOURED SINGLE CORE CABLES

COPPER CONDUCTORS

IEC 60502-2
and BS 6622

$U_0/U (U_m)=8.7/15(17.5) \text{ kV}$

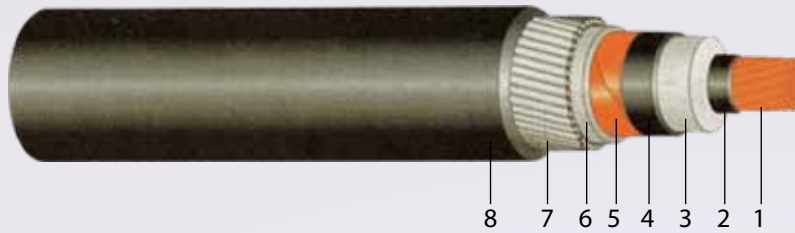

- | | |
|-------------------------------------|---------------------------------|
| 1. Conductor | 5. Insulation Screen (Metallic) |
| 2. Conductor Screen | 6. Bedding |
| 3. XLPE Insulation | 7. Aluminium Wire Armour |
| 4. Insulation Screen (Non-metallic) | 8. Outer Sheath |

Size	Diameter of Conductor (Approx.)	Nominal Insulation Thickness	Diameter Over Insulation (Approx.)	Nominal Diameter of Aluminium Wire	Nominal Outer Sheath Thickness		Overall Diameter (Approx.)		Weight of Cable (Approx)	
				CUT/CUW	CUT	CUW	CUT	CUW	CUT	CUW
mm ²	mm	mm	mm	mm	mm	mm	mm	mm	Kg/km	Kg/km
25	5.9	4.5	16.5	1.6	1.8	1.9	28	30	1100	1325
35	6.9	4.5	17.5	1.6	1.9	1.9	29	31	1250	1475
50	8.1	4.5	18.7	1.6	1.9	1.9	30	32	1375	1625
70	9.7	4.5	20.3	1.6	1.9	2.0	32	34	1650	1875
95	11.4	4.5	22.0	2.0	2.0	2.1	35	36	2050	2300
120	12.9	4.5	23.5	2.0	2.1	2.1	36	38	2350	2600
150	14.3	4.5	24.9	2.0	2.1	2.2	38	40	2675	3000
185	16.0	4.5	26.6	2.0	2.2	2.2	40	41	3150	3450
240	18.4	4.5	29.0	2.0	2.3	2.3	42	44	3800	4125
300	20.4	4.5	31.0	2.0/2.5	2.3	2.4	44	47	4450	4975
400	23.2	4.5	33.8	2.5	2.5	2.5	49	50	5575	6000
500	26.7	4.5	37.3	2.5	2.6	2.6	52	54	6725	7200
630	30.4	4.5	41.0	2.5	2.7	2.7	57	59	8300	8775

Size	Max DC Resistance @ 20°C	Inductance		Capacitance	Conductor Short Circuit Current for 1 second	Current ratings							Voltage drop per phase	
		Trefoil	Flat			Buried Direct In the ground	In single-way ducts		In air					
							Trefoil	Flat Spaced	Trefoil ducts	Flat Touching ducts	Trefoil	Flat Touching		Flat Spaced
mm ²	Ohm/km	mH/km	mH/km	µF/km	kA	Amps	Amps	Amps	Amps	Amps	Amps	Amps	Amps	V/A.Km
25	0.727	0.505	0.796	0.17	3.575	137	142	131	133	162	165	189	189	0.837
35	0.524	0.484	0.771	0.19	5.005	164	168	155	158	196	199	228	228	0.626
50	0.387	0.463	0.745	0.21	7.150	193	197	183	186	234	238	271	271	0.482
70	0.268	0.441	0.719	0.23	10.010	234	238	223	226	291	294	334	334	0.357
95	0.193	0.428	0.703	0.25	13.585	278	280	265	268	353	355	401	401	0.278
120	0.153	0.413	0.684	0.27	17.160	315	313	301	303	406	407	455	455	0.235
150	0.124	0.401	0.668	0.29	21.450	349	340	334	335	460	454	501	501	0.203
185	0.0991	0.388	0.652	0.32	26.455	391	374	376	375	524	513	559	559	0.176
240	0.0754	0.373	0.632	0.35	34.320	446	416	430	425	611	589	633	633	0.149
300	0.0601	0.361	0.616	0.39	42.900	495	451	478	471	692	657	697	697	0.132
400	0.0470	0.346	0.596	0.43	57.200	551	488	534	522	788	733	764	764	0.117
500	0.0366	0.337	0.582	0.48	71.500	593	509	578	555	873	786	815	815	0.105
630	0.0283	0.325	0.565	0.53	90.090	646	542	632	604	975	858	882	882	0.095

Laying condition: Maximum conductor temperature 90°C, Ambient temperature 30°C. Underground temperature of soil 20°C, Depth of laying - 0.8m. Ground thermal resistivity 1.5 K.m/W, thermal resistivity of earthenware ducts 1.2 K.m/W.

Note: Area of copper wire considered is 16 mm² up to 120 mm², 25 mm² from 150 mm² up to 300 mm², 35 mm² from 400 mm² up to 630 mm².



ARMOURED SINGLE CORE CABLES

COPPER CONDUCTORS

IEC 60502-2

and BS 6622

U₀/U (U_m)=12/20(24) kV

12.7/22(24) kV



1. Conductor
2. Conductor Screen
3. XLPE Insulation
4. Insulation Screen (Non-metallic)
5. Insulation Screen (Metallic)
6. Bedding
7. Aluminium Wire Armour
8. Outer Sheath

Size	Diameter of Conductor (Approx.)	Nominal Insulation Thickness	Diameter Over Insulation (Approx.)	Nominal Diameter of Aluminium Wire		Nominal Outer Sheath Thickness		Overall Diameter (Approx.)		Weight of Cable (Approx.)	
				CUT/CUW	CUT	CUW	CUT	CUW	CUT	CUW	
mm ²	mm	mm	mm	mm	mm	mm	mm	mm	mm	Kg/km	Kg/km
25	5.9	6.0	19.5	1.6	1.9	2.0	31	33	1300	1525	
35	6.9	5.5	19.5	1.6	1.9	2.0	31	33	1375	1600	
50	8.1	5.5	20.7	1.6	2.0	2.0	33	35	1550	1825	
70	9.7	5.5	22.3	2.0	2.0	2.1	35	37	1850	2100	
95	11.4	5.5	24.0	2.0	2.1	2.1	37	38	2200	2475	
120	12.9	5.5	25.5	2.0	2.1	2.2	38	40	2550	2800	
150	14.3	5.5	26.9	2.0	2.2	2.2	40	41	2900	3175	
185	16.0	5.5	28.6	2.0	2.2	2.3	42	43	3275	3650	
240	18.4	5.5	31.0	2.0/2.5	2.3	2.4	44	47	3975	4500	
300	20.4	5.5	33.0	2.5	2.4	2.5	48	49	4825	5175	
400	23.2	5.5	35.8	2.5	2.5	2.6	51	53	5725	6250	
500	26.7	5.5	39.3	2.5	2.6	2.7	55	57	7000	7500	
630	30.4	5.5	43.0	2.5	2.8	2.8	59	61	8550	9050	

Size	Max DC Resistance @ 20°C	Inductance		Capacitance	Conductor Short Circuit Current for 1 second	Current ratings						Voltage drop per phase	
		Trefoil	Flat			Buried Direct In the ground	In single-way ducts		In air				
							Trefoil	Flat Spaced	Trefoil ducts	Flat Touching ducts	Trefoil		Flat Touching
mm ²	Ohm/km	mH/km	mH/km	µF/km	kA	Amps	Amps	Amps	Amps	Amps	Amps	Amps	V/A.Km
25	0.727	0.504	0.805	0.14	3.575	137	142	131	133	162	165	189	0.841
35	0.524	0.496	0.776	0.16	5.005	164	168	155	158	196	199	228	0.628
50	0.387	0.474	0.751	0.18	7.150	193	197	183	186	234	238	271	0.484
70	0.268	0.452	0.724	0.20	10.010	234	238	223	226	291	294	334	0.359
95	0.193	0.438	0.708	0.21	13.585	278	280	265	268	353	355	401	0.280
120	0.153	0.423	0.689	0.23	17.160	315	313	301	303	406	407	455	0.237
150	0.124	0.410	0.673	0.25	21.450	349	340	334	335	460	454	501	0.205
185	0.0991	0.397	0.657	0.27	26.455	391	374	376	375	524	513	559	0.178
240	0.0754	0.392	0.637	0.30	34.320	446	416	430	425	611	589	633	0.153
300	0.0601	0.370	0.621	0.33	42.900	495	451	478	471	692	657	697	0.133
400	0.0470	0.345	0.601	0.37	57.200	551	488	534	522	788	733	764	0.118
500	0.0366	0.355	0.586	0.40	71.500	593	509	578	555	873	786	815	0.106
630	0.0283	0.333	0.569	0.45	90.090	646	542	632	604	975	858	882	0.097

Laying condition: Maximum conductor temperature 90°C, Ambient temperature 30°C. Underground temperature of soil 20°C, Depth of laying - 0.8m. Ground thermal resistivity 1.5 K.m/W, thermal resistivity of earthenware ducts 1.2 K.m/W.

Note: Area of copper wire considered is 16 mm² up to 120 mm², 25 mm² from 150 mm² up to 300 mm², 35 mm² from 400 mm² up to 630 mm².



ARMOURED SINGLE CORE CABLES

COPPER CONDUCTORS

IEC 60502-2
and BS 6622

$U_0/U (U_m)=18/30(36) \text{ kV}$
 $19/33(36) \text{ kV}$

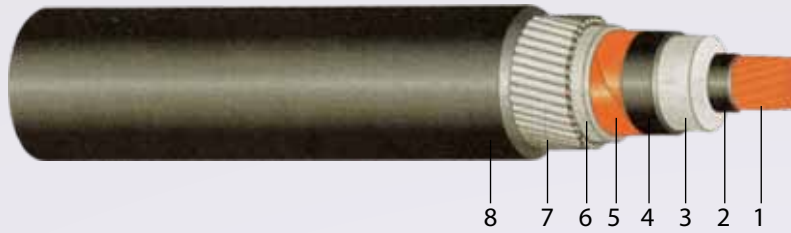

- | | |
|-------------------------------------|---------------------------------|
| 1. Conductor | 5. Insulation Screen (Metallic) |
| 2. Conductor Screen | 6. Bedding |
| 3. XLPE Insulation | 7. Aluminium Wire Armour |
| 4. Insulation Screen (Non-metallic) | 8. Outer Sheath |

Size	Diameter of Conductor (Approx.)	Nominal Insulation Thickness	Diameter Over Insulation (Approx.)	Nominal Diameter of Aluminium Wire		Nominal Outer Sheath Thickness		Overall Diameter (Approx.)		Weight of Cable (Approx)	
				CUT/CUW	CUT	CUW	CUT	CUW	CUT	CUW	
mm ²	mm	mm	mm	mm	mm	mm	mm	mm	Kg/km	Kg/km	
50	8.1	8.0	25.7	2.0	2.2	2.2	39	40	2025	2250	
70	9.7	8.0	27.3	2.0	2.2	2.3	40	42	2300	2575	
95	11.4	8.0	29.0	2.0	2.3	2.3	42	44	2675	2900	
120	12.9	8.0	30.5	2.0/2.5	2.3	2.4	44	46	2950	3225	
150	14.3	8.0	31.9	2.5	2.4	2.5	47	48	3500	3850	
185	16.0	8.0	33.6	2.5	2.5	2.5	49	50	3925	4300	
240	18.4	8.0	36.0	2.5	2.5	2.6	51	53	4600	5025	
300	20.4	8.0	38.0	2.5	2.6	2.7	53	55	5375	5725	
400	23.2	8.0	40.8	2.5	2.7	2.8	57	59	6350	6850	
500	26.7	8.0	44.3	2.5	2.8	2.9	61	63	7600	8100	
630	30.4	8.0	48.0	2.5	2.9	3.0	65	67	9100	9700	

Size	Max DC Resistance @ 20°C	Inductance		Capacitance	Conductor Short Circuit Current for 1 second	Current ratings							Voltage drop per phase	
		Trefoil	Flat			Buried Direct In the ground		In single -way ducts		In air				
						Trefoil	Flat Spaced	Trefoil ducts	Flat Touching ducts	Trefoil	Flat Touching	Flat Spaced		
mm ²	Ohm/km	mH/km	mH/km	μF/km	kA	Amps	Amps	Amps	Amps	Amps	Amps	Amps	Amps	V/A.Km
50	0.387	0.504	0.766	0.14	7.150	193	197	183	186	234	238	271	0.490	
70	0.268	0.481	0.740	0.16	10.010	234	238	223	226	291	294	334	0.364	
95	0.193	0.467	0.723	0.17	13.585	278	280	265	268	353	355	401	0.286	
120	0.153	0.450	0.704	0.18	17.160	315	313	301	303	406	407	455	0.242	
150	0.124	0.437	0.688	0.19	21.450	349	340	334	335	460	454	501	0.21	
185	0.0991	0.424	0.672	0.21	26.455	391	374	376	375	524	513	559	0.182	
240	0.0754	0.407	0.652	0.23	34.320	446	416	430	425	611	589	633	0.156	
300	0.0601	0.394	0.635	0.25	42.900	495	451	478	471	692	657	697	0.138	
400	0.0470	0.377	0.614	0.27	57.200	551	488	534	522	788	733	764	0.122	
500	0.0366	0.366	0.599	0.30	71.500	593	509	578	555	873	786	815	0.111	
630	0.0283	0.357	0.582	0.33	90.090	646	542	632	604	975	858	882	0.101	

Laying condition: Maximum conductor temperature 90°C, Ambient temperature 30°C. Underground temperature of soil 20°C, Depth of laying - 0.8m. Ground thermal resistivity 1.5 K.m/W, thermal resistivity of earthenware ducts 1.2 K.m/W.

Note: Area of copper wire considered is 16 mm² up to 120 mm², 25 mm² from 150 mm² up to 300 mm², 35 mm² from 400 mm² up to 630 mm².



UNARMoured THREE CORE CABLES

COPPER CONDUCTORS

IEC 60502-2
and BS 6622

$U_0/U (Um)=3.6/6(7.2) \text{ kV}$
 $3.8/6.6(7.2) \text{ kV}$

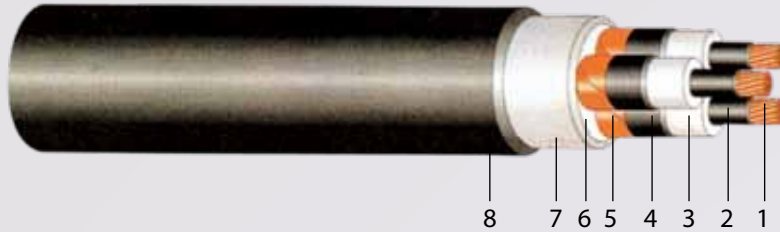

- | | |
|-------------------------------------|---------------------------------|
| 1. Conductor | 5. Insulation Screen (Metallic) |
| 2. Conductor Screen | 6. PP Filler |
| 3. XLPE Insulation | 7. Bedding |
| 4. Insulation Screen (Non-metallic) | 8. Outer Sheath |

Size	Diameter of Conductor (Approx.)	Nominal Insulation Thickness	Diameter Over Insulation (Approx.)	Nominal Outer Sheath Thickness		Overall Diameter (Approx.)		Weight of Cable (Approx)	
				CUT	CUW	CUT	CUW	CUT	CUW
mm ²	mm	mm	mm	mm	mm	mm	mm	Kg/km	Kg/km
25	5.9	2.5	12.5	2.1	2.1	39	42	1925	2075
35	6.9	2.5	13.5	2.1	2.2	41	44	2300	2450
50	8.1	2.5	14.7	2.2	2.3	44	47	2775	2950
70	9.7	2.5	16.3	2.3	2.4	48	51	3550	3700
95	11.4	2.5	18.	2.5	2.5	52	55	4500	4600
120	12.9	2.5	19.5	2.6	2.6	56	59	5350	5475
150	14.3	2.5	20.9	2.7	2.8	59	62	6350	6550
185	16.0	2.5	22.6	2.8	2.9	63	66	7550	7725
240	18.4	2.6	25.2	3.0	3.0	69	72	9500	9675
300	20.4	2.8	27.6	3.2	3.2	75	78	11650	11875

Size	Max DC Resistance @ 20°C	Nominal Inductance	Capacitance	Conductor Short Circuit Current for 1 second	Current ratings			Voltage drop Per phase
					Buried Direct In the ground	In buried ducts	In air	
mm ²	Ohm/km	mH/km	µF/km	kA	Amps	Amps	Amps	V/A.Km
25	0.727	0.305	0.26	3.575	129	112	142	0.799
35	0.524	0.294	0.29	5.005	153	133	170	0.590
50	0.387	0.283	0.32	7.150	181	158	204	0.448
70	0.268	0.272	0.36	10.010	221	193	253	0.325
95	0.193	0.266	0.39	13.585	262	231	304	0.248
120	0.153	0.259	0.43	17.160	298	264	351	0.206
150	0.124	0.253	0.47	21.450	334	297	398	0.175
185	0.0991	0.250	0.52	26.455	377	336	455	0.150
240	0.0754	0.243	0.56	34.320	434	390	531	0.125
300	0.0601	0.236	0.58	42.900	489	441	606	0.108

Laying condition: Maximum conductor temperature 90°C, Ambient temperature 30°C. Underground temperature of soil 20°C, Depth of laying - 0.8m. Ground thermal resistivity 1.5 K.m/W, thermal resistivity of earthenware ducts 1.2 K.m/W.

Note: Area of copper wire considered is 16 mm² up to 120 mm², 25 mm² from 150 mm² up to 300 mm², 35 mm² from 400 mm² up to 630 mm².



UNARMoured THREE CORE CABLES

COPPER CONDUCTORS

IEC 60502-2
and BS 6622

U₀/U (U_m)=6 /10(12) kV
6.35/11(12) kV

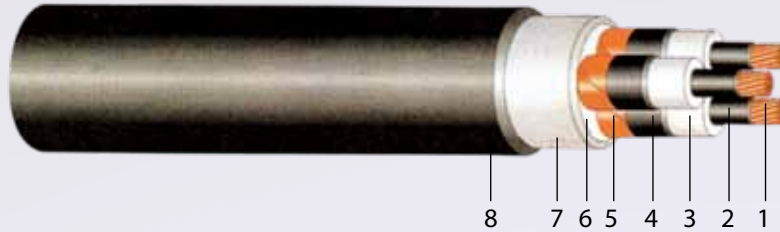

- | | |
|-------------------------------------|---------------------------------|
| 1. Conductor | 5. Insulation Screen (Metallic) |
| 2. Conductor Screen | 6. PP Filler |
| 3. XLPE Insulation | 7. Bedding |
| 4. Insulation Screen (Non-metallic) | 8. Outer Sheath |

Size	Diameter of Conductor (Approx.)	Nominal Insulation Thickness	Diameter Over Insulation (Approx.)	Nominal Outer Sheath Thickness		Overall Diameter (Approx.)		Weight of Cable (Approx)	
				CUT	CUW	CUT	CUW	CUT	CUW
mm ²	mm	mm	mm	mm	mm	mm	mm	Kg/km	Kg/km
25	5.9	3.4	14.3	2.2	2.2	43	46	2125	2300
35	6.9	3.4	15.3	2.3	2.3	46	48	2575	2750
50	8.1	3.4	16.5	2.4	2.4	48	51	3050	3250
70	9.7	3.4	18.1	2.5	2.5	52	55	3825	4000
95	11.4	3.4	19.8	2.6	2.7	56	59	4750	5000
120	12.9	3.4	21.3	2.7	2.8	60	63	5675	5850
150	14.3	3.4	22.7	2.8	2.9	63	65	6625	6875
185	16.0	3.4	24.4	2.9	3.0	67	70	7875	8150
240	18.4	3.4	26.8	3.1	3.2	73	76	9900	10225
300	20.4	3.4	28.8	3.3	3.3	78	81	11975	12200

Size	Max DC Resistance @ 20°C	Nominal Inductance	Capacitance	Conductor Short Circuit Current for 1 second	Current ratings			Voltage drop Per phase
					Buried Direct In the ground	In buried ducts	In air	
mm ²	Ohm/km	mH/km	μF/km	kA	Amps	Amps	Amps	V/A.Km
25	0.727	0.331	0.21	3.575	129	112	142	0.804
35	0.524	0.318	0.23	5.005	153	133	170	0.595
50	0.387	0.305	0.25	7.150	181	158	204	0.453
70	0.268	0.292	0.29	10.010	221	193	253	0.329
95	0.193	0.285	0.31	13.585	262	231	304	0.252
120	0.153	0.276	0.34	17.160	298	264	351	0.209
150	0.124	0.269	0.37	21.450	334	297	398	0.179
185	0.0991	0.263	0.40	26.455	377	336	455	0.152
240	0.0754	0.255	0.44	34.320	434	390	531	0.127
300	0.0601	0.248	0.48	42.900	489	441	606	0.111

Laying condition: Maximum conductor temperature 90°C, Ambient temperature 30°C. Underground temperature of soil 20°C, Depth of laying 0.8m. Ground thermal resistivity 1.5 K.m/W, thermal resistivity of earthenware ducts 1.2 K.m/W.

Note: Area of copper wire considered is 16 mm² up to 120 mm², 25 mm² from 150 mm² up to 300 mm², 35 mm² from 400 mm² up to 630 mm².



UNARMoured THREE CORE CABLES

COPPER CONDUCTORS

IEC 60502-2
and BS 6622

$U_0/U (U_m)=8.7/15(17.5) \text{ kV}$

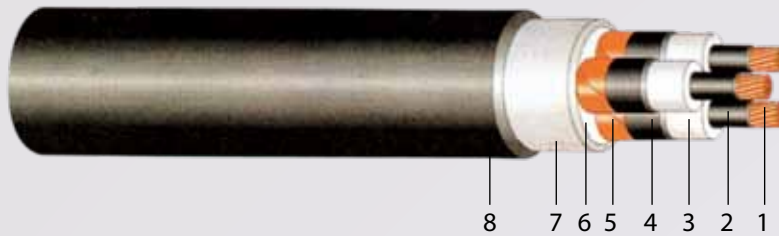

- | | |
|-------------------------------------|---------------------------------|
| 1. Conductor | 5. Insulation Screen (Metallic) |
| 2. Conductor Screen | 6. PP Filler |
| 3. XLPE Insulation | 7. Bedding |
| 4. Insulation Screen (Non-metallic) | 8. Outer Sheath |

size	Diameter of Conductor (Approx.)	Nominal Insulation Thickness	Diameter Over Insulation (Approx.)	Nominal Outer Sheath Thickness		Overall Diameter (Approx.)		Weight of Cable (Approx)	
				CUT	CUW	CUT	CUW	CUT	CUW
mm ²	mm	mm	mm	mm	mm	mm	mm	Kg/km	Kg/km
25	5.9	4.5	16.5	2.4	2.4	47	50	2550	2700
35	6.9	4.5	17.5	2.5	2.5	51	54	2950	3125
50	8.1	4.5	18.7	2.6	2.6	53	56	3450	3600
70	9.7	4.5	20.3	2.7	2.7	58	61	4300	4450
95	11.4	4.5	22.0	2.8	2.8	61	64	5275	5425
120	12.9	4.5	23.5	2.9	2.9	65	68	6150	6300
150	14.3	4.5	24.9	3.0	3.1	66	71	7125	7400
185	16.0	4.5	26.6	3.1	3.2	72	76	8500	8800
240	18.4	4.5	29.0	3.3	3.3	78	81	10550	10775
300	20.4	4.5	31.0	3.4	3.5	83	86	12550	12800

Size	Max DC Resistance @ 20°C	Nominal Inductance	Capacitance	Conductor Short Circuit Current for 1 second	Current ratings			Voltage drop Per phase
					Buried Direct In the ground	In buried ducts	In air	
mm ²	Ohm/km	mH/km	µF/km	kA	Amps	Amps	Amps	V/A.Km
25	0.727	0.359	0.17	3.575	129	112	142	0.809
35	0.524	0.344	0.19	5.005	153	133	170	0.600
50	0.387	0.329	0.21	7.150	181	158	204	0.457
70	0.268	0.314	0.23	10.010	221	193	253	0.333
95	0.193	0.306	0.25	13.585	262	231	304	0.255
120	0.153	0.296	0.27	17.160	298	264	351	0.213
150	0.124	0.288	0.29	21.450	334	297	398	0.182
185	0.0991	0.280	0.32	26.455	377	336	455	0.155
240	0.0754	0.271	0.35	34.320	434	390	531	0.130
300	0.0601	0.260	0.39	42.900	489	441	606	0.113

Laying condition: Maximum conductor temperature 90°C, Ambient temperature 30°C. Underground temperature of soil 20°C, Depth of laying - 0.8m. Ground thermal resistivity 1.5 K.m/W, thermal resistivity of earthenware ducts 1.2 K.m/W.

Note: Area of copper wire considered is 16 mm² up to 120 mm², 25 mm² from 150 mm² up to 300 mm², 35 mm² from 400 mm² up to 630 mm².



UNARMoured THREE CORE CABLES

COPPER CONDUCTORS

IEC 60502-2
and BS 6622

$U_0/U (U_m)=12/20(24) \text{ kV}$
 $12.7/22(24) \text{ kV}$

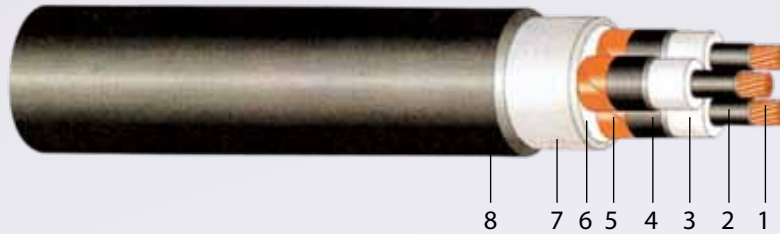

1. Conductor
2. Conductor Screen
3. XLPE Insulation
4. Insulation Screen (Non-metallic)
5. Insulation Screen (Metallic)
6. PP Filler
7. Bedding
8. Outer Sheath

Size	Diameter of Conductor (Approx.)	Nominal Insulation Thickness	Diameter Over Insulation (Approx.)	Nominal Outer Sheath Thickness		Overall Diameter (Approx.)		Weight of Cable (Approx)	
				CUT	CUW	CUT	CUW	CUT	CUW
mm ²	mm	mm	mm	mm	mm	mm	mm	Kg/km	Kg/km
25	5.9	6.0	19.5	2.6	2.6	55	59	3075	3275
35	6.9	5.5	19.5	2.6	2.7	55	59	3900	3550
50	8.1	5.5	20.7	2.7	2.8	58	62	4000	4100
70	9.7	5.5	22.3	2.8	2.9	62	65	4725	4900
95	11.4	5.5	24.0	2.9	3.0	66	69	5700	6000
120	12.9	5.5	25.5	3.0	3.1	70	73	6700	6900
150	14.3	5.5	26.9	3.1	3.2	73	76	7775	8000
185	16.0	5.5	28.6	3.3	3.3	78	80	9100	9325
240	18.4	5.5	31.0	3.4	3.5	83	86	11100	11300
300	20.4	5.5	33.0	3.6	3.6	88	90	13150	13350

Size	Max DC Resistance @ 20°C	Nominal Inductance	Capacitance	Conductor Short Circuit Current for 1 second	Current ratings			Voltage drop Per phase
					Buried Direct In the ground	In buried ducts	In air	
mm ²	Ohm/km	mH/km	μF/km	kA	Amps	Amps	Amps	V/A.Km
25	0.727	0.394	0.14	3.575	129	112	142	0.816
35	0.524	0.365	0.16	5.005	153	133	170	0.604
50	0.387	0.349	0.18	7.150	181	158	204	0.461
70	0.268	0.332	0.20	10.010	221	193	253	0.336
95	0.193	0.323	0.21	13.585	262	231	304	0.258
120	0.153	0.312	0.23	17.160	298	264	351	0.216
150	0.124	0.303	0.25	21.450	334	297	398	0.185
185	0.0991	0.295	0.27	26.455	377	336	455	0.158
240	0.0754	0.285	0.30	34.320	434	390	531	0.133
300	0.0601	0.270	0.33	42.900	489	441	606	0.115

Laying condition: Maximum conductor temperature 90°C, Ambient temperature 30°C. Underground temperature of soil 20°C, Depth of laying - 0.8m. Ground thermal resistivity 1.5 K.m/W, thermal resistivity of earthenware ducts 1.2 K.m/W.

Note: Area of copper wire considered is 16 mm² up to 120 mm², 25 mm² from 150 mm² up to 300 mm², 35 mm² from 400 mm² up to 630 mm².



UNARMoured THREE CORE CABLES

COPPER CONDUCTORS

IEC 60502-2
and BS 6622

$U_0/U (Um)=18/30(36) \text{ kV}$
 $19/33(36) \text{ kV}$

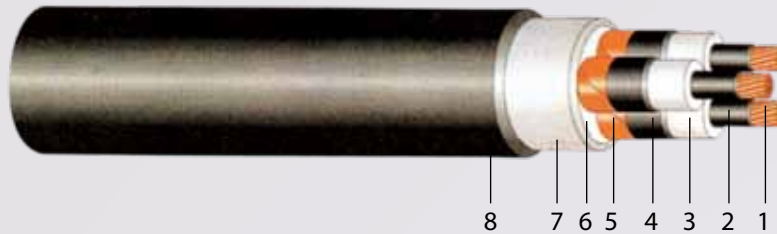

- | | |
|-------------------------------------|---------------------------------|
| 1. Conductor | 5. Insulation Screen (Metallic) |
| 2. Conductor Screen | 6. PP Filler |
| 3. XLPE Insulation | 7. Bedding |
| 4. Insulation Screen (Non-metallic) | 8. Outer Sheath |

Size	Diameter of Conductor (Approx.)	Nominal Insulation Thickness	Diameter Over Insulation (Approx.)	Nominal Outer Sheath Thickness		Overall Diameter (Approx.)		Weight of Cable (Approx)	
				CUT	CUW	CUT	CUW	CUT	CUW
mm ²	mm	mm	mm	mm	mm	mm	mm	Kg/km	Kg/km
50	8.1	8.0	25.7	3.1	3.1	71	73	5100	5250
70	9.7	8.0	27.3	3.2	3.2	75	77	6100	6200
95	11.4	8.0	29.0	3.3	3.4	78	81	7150	7300
120	12.9	8.0	30.5	3.4	3.5	82	85	8100	8300
150	14.3	8.0	31.9	3.5	3.6	85	88	9150	9400
185	16.0	8.0	33.6	3.6	3.7	89	92	10500	10750
240	18.4	8.0	36.0	3.8	3.9	95	98	12600	12950
300	20.4	8.0	38.0	4.0	4.0	100	102	14900	15050

Size	Max DC Resistance @ 20°C	Nominal Inductance	Capacitance	Conductor Short Circuit Current for 1 second	Current ratings			Voltage drop Per phase
					Buried Direct In the ground	In buried ducts	In air	
mm ²	Ohm/km	mH/km	μF/km	kA	Amps	Amps	Amps	V/A.Km
50	0.387	0.399	0.14	7.150	181	158	204	0.47
70	0.268	0.380	0.16	10.010	221	193	253	0.345
95	0.193	0.369	0.17	13.585	262	231	304	0.267
120	0.153	0.355	0.18	17.160	298	264	351	0.224
150	0.124	0.345	0.19	21.450	334	297	398	0.192
185	0.0991	0.334	0.21	26.455	377	336	455	0.166
240	0.0754	0.321	0.23	34.320	434	390	531	0.14
300	0.0601	0.308	0.25	42.900	489	441	606	0.122

Laying condition: Maximum conductor temperature 90°C, Ambient temperature 30°C. Underground temperature of soil 20°C, Depth of laying - 0.8m. Ground thermal resistivity 1.5 K.m/W, thermal resistivity of earthenware ducts 1.2 K.m/W.

Note: Area of copper wire considered is 16 mm² up to 120 mm², 25 mm² from 150 mm² up to 300 mm², 35 mm² from 400 mm² up to 630 mm².



ARMOURED THREE CORE CABLES

COPPER CONDUCTORS

IEC 60502-2
and BS 6622

$U_0/U (U_m)=3.6/6(7.2) \text{ kV}$
 $3.8/6.6(7.2) \text{ kV}$



- | | |
|-------------------------------------|----------------------|
| 1. Conductor | 6. PP Filler |
| 2. Conductor Screen | 7. Bedding |
| 3. XLPE Insulation | 8. Steel Wire Armour |
| 4. Insulation Screen (Non-metallic) | 9. Outer Sheath |
| 5. Insulation Screen (Metallic) | |

Size	Diameter of Conductor (Approx.)	Nominal Insulation Thickness	Diameter Over Insulation (Approx.)	Nominal Diameter of steel wire	Nominal Outer Sheath Thickness		Overall Diameter (Approx.)		Weight of Cable (Approx)	
				CUT/CUW	CUT	CUW	CUT	CUW	CUT	CUW
mm ²	mm	mm	mm	mm	mm	mm	mm	mm	Kg/km	Kg/km
25	5.9	2.5	12.5	2.0	2.3	2.3	43	46	3300	3675
35	6.9	2.5	13.5	2.0/2.5	2.3	2.4	45	50	3750	4475
50	8.1	2.5	14.7	2.5	2.5	2.5	49	52	4775	5100
70	9.7	2.5	16.3	2.5	2.6	2.6	53	56	5725	6000
95	11.4	2.5	18.0	2.5	2.7	2.8	57	60	6800	7150
120	12.9	2.5	19.5	2.5	2.8	2.9	61	64	7850	8150
150	14.3	2.5	20.9	2.5	2.9	3.0	64	67	8900	9350
185	16.0	2.5	22.6	2.5	3.1	3.1	68	71	10375	10750
240	18.4	2.6	25.2	2.5/3.15	3.3	3.4	74	78	12600	13950
300	20.4	2.8	27.6	3.15	3.5	3.6	82	85	16050	16475

Size	Max DC Resistance @ 20°C	Nominal Inductance	Capacitance	Conductor Short Circuit Current for 1 second	Current ratings			Voltage drop Per phase
					Buried Direct In the ground	In buried ducts	In air	
mm ²	Ohm/km	mH/km	µF/km	kA	Amps	Amps	Amps	V/A.Km
25	0.727	0.363	0.26	3.575	129	112	143	0.81
35	0.524	0.344	0.29	5.005	154	134	172	0.60
50	0.387	0.333	0.32	7.150	181	158	205	0.458
70	0.268	0.322	0.36	10.010	220	194	253	0.334
95	0.193	0.316	0.39	13.585	263	232	307	0.257
120	0.153	0.309	0.43	17.160	298	264	352	0.215
150	0.124	0.303	0.47	21.450	332	296	397	0.185
185	0.0991	0.300	0.52	26.455	374	335	453	0.159
240	0.0754	0.293	0.56	34.320	431	387	529	0.124
300	0.0601	0.286	0.58	42.900	482	435	599	0.118

Laying condition: Maximum conductor temperature 90°C, Ambient temperature 30°C. Underground temperature of soil 20°C, Depth of laying - 0.8m. Ground thermal resistivity 1.5 K.m/W, thermal resistivity of earthenware ducts 1.2 K.m/W.

Note: Area of copper wire considered is 16 mm² up to 120 mm², 25 mm² from 150 mm² up to 300 mm², 35 mm² from 400 mm² up to 630 mm².



ARMOURED THREE CORE CABLES

COPPER CONDUCTORS

IEC 60502-2
and BS 6622

$U_0/U (U_m)=6 /10(12) \text{ kV}$
 $6.35/11(12) \text{ kV}$



- | | |
|-------------------------------------|----------------------|
| 1. Conductor | 6. PP Filler |
| 2. Conductor Screen | 7. Bedding |
| 3. XLPE Insulation | 8. Steel Wire Armour |
| 4. Insulation Screen (Non-metallic) | 9. Outer Sheath |
| 5. Insulation Screen (Metallic) | |

Size	Diameter of Conductor (Approx.)	Nominal Insulation Thickness	Diameter Over Insulation (Approx.)	Nominal Diameter of steel wire	Nominal Outer Sheath Thickness		Overall Diameter (Approx.)		Weight of Cable (Approx)	
				CUT/CUW	CUT	CUW	CUT	CUW	CUT	CUW
mm ²	mm	mm	mm	mm	mm	mm	mm	mm	Kg/km	Kg/km
25	5.9	3.4	14.3	2.5	2.4	2.5	48	52	4150	4450
35	6.9	3.4	15.3	2.5	2.5	2.6	51	54	4625	5000
50	8.1	3.4	16.5	2.5	2.6	2.7	54	57	5300	5625
70	9.7	3.4	18.1	2.5	2.7	2.8	57	61	6200	6575
95	11.4	3.4	19.8	2.5	2.9	2.9	62	65	7425	7700
120	12.9	3.4	21.3	2.5	3.0	3.0	65	68	8475	8750
150	14.3	3.4	22.7	2.5	3.1	3.1	68	72	9550	9975
185	16.0	3.4	24.4	2.5	3.2	3.3	72	76	11000	11425
240	18.4	3.4	26.8	3.15	3.4	3.5	80	83	14300	14775
300	20.4	3.4	28.8	3.15	3.6	3.6	85	88	16625	17050

Size	Max DC Resistance @ 20°C	Nominal Inductance	Capacitance	Conductor Short Circuit Current for 1 second	Current ratings			Voltage drop Per phase
					Buried Direct In the ground	In buried ducts	In air	
mm ²	Ohm/km	mH/km	μF/km	kA	Amps	Amps	Amps	V/A.Km
25	0.727	0.387	0.21	3.575	129	112	143	0.815
35	0.524	0.368	0.23	5.005	154	134	172	0.604
50	0.387	0.355	0.25	7.150	181	158	205	0.462
70	0.268	0.342	0.29	10.010	220	194	253	0.338
95	0.193	0.335	0.31	13.585	263	232	307	0.261
120	0.153	0.326	0.34	17.160	298	264	352	0.218
150	0.124	0.319	0.37	21.450	332	296	397	0.188
185	0.0991	0.313	0.40	26.455	374	335	453	0.161
240	0.0754	0.305	0.44	34.320	431	387	529	0.137
300	0.0601	0.297	0.48	42.900	482	435	599	0.120

Laying condition: Maximum conductor temperature 90°C, Ambient temperature 30°C. Underground temperature of soil 20°C, Depth of laying - 0.8m. Ground thermal resistivity 1.5 K.m/W, thermal resistivity of earthenware ducts 1.2 K.m/W.

Note: Area of copper wire considered is 16 mm² up to 120 mm², 25 mm² from 150 mm² up to 300 mm², 35 mm² from 400 mm² up to 630 mm².



ARMOURED THREE CORE CABLES

COPPER CONDUCTORS

IEC 60502-2
and BS 6622

U_o/U (U_m)=8.7/15(17.5) kV



- | | |
|-------------------------------------|----------------------|
| 1. Conductor | 6. PP Filler |
| 2. Conductor Screen | 7. Bedding |
| 3. XLPE Insulation | 8. Steel Wire Armour |
| 4. Insulation Screen (Non-metallic) | 9. Outer Sheath |
| 5. Insulation Screen (Metallic) | |

Size	Diameter of Conductor (Approx.)	Nominal Insulation Thickness	Diameter Over Insulation (Approx.)	Nominal Diameter of steel wire	Nominal Outer Sheath Thickness		Overall Diameter (Approx.)		Weight of Cable (Approx)	
				CUT/CUW	CUT	CUW	CUT	CUW	CUT	CUW
mm ²	mm	mm	mm	mm	mm	mm	mm	mm	Kg/km	Kg/km
25	5.9	4.5	16.5	2.5	2.6	2.6	53	56	4800	5075
35	6.9	4.5	17.5	2.5	2.7	2.7	56	59	5300	5575
50	8.1	4.5	18.7	2.5	2.8	2.8	59	62	5950	6300
70	9.7	4.5	20.3	2.5	2.9	3.0	63	66	6925	7300
95	11.4	4.5	22.0	2.5	3.0	3.1	67	70	8100	8425
120	12.9	4.5	23.5	2.5	3.1	3.2	70	74	9175	9525
150	14.3	4.5	24.9	2.5/3.15	3.2	3.3	75	78	10325	11625
185	16.0	4.5	26.6	3.15	3.4	3.5	80	83	12900	13300
240	18.4	4.5	29.0	3.15	3.6	3.7	86	89	15225	15625
300	20.4	4.5	31.0	3.15	3.7	3.8	91	94	17525	17975

Size	Max DC Resistance @ 20°C	Nominal Inductance	Capacitance	Conductor Short Circuit Current for 1 second	Current ratings			Voltage drop Per phase
					Buried Direct In the ground	In buried ducts	In air	
mm ²	Ohm/km	mH/km	µF/km	kA	Amps	Amps	Amps	V/A.Km
25	0.727	0.413	0.17	3.575	129	112	143	0.820
35	0.524	0.394	0.19	5.005	154	134	172	0.609
50	0.387	0.379	0.21	7.150	181	158	205	0.466
70	0.268	0.364	0.23	10.010	220	194	253	0.342
95	0.193	0.356	0.25	13.585	263	232	307	0.265
120	0.153	0.346	0.27	17.160	298	264	352	0.222
150	0.124	0.338	0.29	21.450	332	296	397	0.191
185	0.0991	0.330	0.32	26.455	374	335	453	0.165
240	0.0754	0.321	0.35	34.320	431	387	529	0.140
300	0.0601	0.312	0.39	42.900	482	435	599	0.123

Laying condition: Maximum conductor temperature 90°C, Ambient temperature 30°C. Underground temperature of soil 20°C, Depth of laying - 0.8m. Ground thermal resistivity 1.5 K.m/W, thermal resistivity of earthenware ducts 1.2 K.m/W.

Note: Area of copper wire considered is 16 mm² up to 120 mm², 25 mm² from 150 mm² up to 300 mm², 35 mm² from 400 mm² up to 630 mm².



ARMOURED THREE CORE CABLES

COPPER CONDUCTORS

IEC 60502-2
and BS 6622

$U_0/U(U_m)=12/20(24)$ kV
 $12.7/22(24)$ kV



- | | |
|-------------------------------------|----------------------|
| 1. Conductor | 6. PP Filler |
| 2. Conductor Screen | 7. Bedding |
| 3. XLPE Insulation | 8. Steel Wire Armour |
| 4. Insulation Screen (Non-metallic) | 9. Outer Sheath |
| 5. Insulation Screen (Metallic) | |

SIZE	Diameter of Conductor (Approx.)	Nominal Insulation Thickness	Diameter Over Insulation (Approx.)	Nominal Diameter of steel wire	Nominal Outer Sheath Thickness		Overall Diameter (Approx.)		Weight of Cable (Approx)	
				CUT/CUW	CUT	CUW	CUT	CUW	CUT	CUW
mm ²	mm	mm	mm	mm	mm	mm	mm	mm	Kg/km	Kg/km
25	5.9	6.0	19.5	2.5	2.8	2.9	61	64	5675	5975
35	6.9	5.5	19.5	2.5	2.8	2.9	61	64	5900	6200
50	8.1	5.5	20.7	2.5	3	3.0	64	67	6600	6925
70	9.7	5.5	22.3	2.5	3.1	3.1	68	71	7600	7925
95	11.4	5.5	24.0	2.5	3.2	3.3	73	75	8850	9100
120	12.9	5.5	25.5	3.15	3.3	3.4	77	81	10875	11300
150	14.3	5.5	26.9	3.15	3.4	3.5	81	84	12100	12600
185	16.0	5.5	28.6	3.15	3.6	3.6	85	88	13775	14125
240	18.4	5.5	31.0	3.15	3.7	3.8	91	94	16050	16525
300	20.4	5.5	33.0	3.15	3.9	4.0	95	99	18400	18900

Size	Max DC Resistance @ 20°C	Nominal Inductance	Capacitance	Conductor Short Circuit Current for 1 second	Current ratings			Voltage drop Per phase
					Buried Direct In the ground	In buried ducts	In air	
mm ²	Ohm/km	mH/km	µF/km	kA	Amps	Amps	Amps	V/A.Km
25	0.727	0.444	0.14	3.575	129	112	143	0.825
35	0.524	0.415	0.16	5.005	154	134	172	0.613
50	0.387	0.399	0.18	7.150	181	158	205	0.47
70	0.268	0.382	0.20	10.010	220	194	253	0.346
95	0.193	0.373	0.21	13.585	263	232	307	0.268
120	0.153	0.362	0.23	17.160	298	264	352	0.225
150	0.124	0.353	0.25	21.450	332	296	397	0.194
185	0.0991	0.345	0.27	26.455	374	335	453	0.167
240	0.0754	0.335	0.30	34.320	431	387	529	0.142
300	0.0601	0.320	0.33	42.900	482	435	599	0.124

Laying condition: Maximum conductor temperature 90°C, Ambient temperature 30°C. Underground temperature of soil 20°C, Depth of laying - 0.8m. Ground thermal resistivity 1.5 K.m/W, thermal resistivity of earthenware ducts 1.2 K.m/W.

Note: Area of copper wire considered is 16 mm² up to 120 mm², 25 mm² from 150 mm² up to 300 mm², 35 mm² from 400 mm² up to 630 mm².



ARMOURED THREE CORE CABLES

COPPER CONDUCTORS

IEC 60502-2
and BS 6622

$U_0/U (U_m)=18/30(36) \text{ kV}$
 $19/33(36) \text{ kV}$



- | | |
|-------------------------------------|----------------------|
| 1. Conductor | 6. PP Filler |
| 2. Conductor Screen | 7. Bedding |
| 3. XLPE Insulation | 8. Steel Wire Armour |
| 4. Insulation Screen (Non-metallic) | 9. Outer Sheath |
| 5. Insulation Screen (Metallic) | |

Size	Diameter of Conductor (Approx.)	Nominal Insulation Thickness	Diameter Over Insulation (Approx.)	Nominal Diameter of steel Wire	Nominal Outer Sheath Thickness		Overall Diameter (Approx.)		Weight of Cable (Approx)	
				CUT/CUW	CUT	CUW	CUT	CUW	CUT	CUW
mm ²	mm	mm	mm	mm	mm	mm	mm	mm	Kg/km	Kg/km
50	8.1	8.0	25.7	3.15	3.4	3.4	78	81	9400	9725
70	9.7	8.0	27.3	3.15	3.5	3.5	82	85	10475	10850
95	11.4	8.0	29.0	3.15	3.6	3.7	86	89	11775	12150
120	12.9	8.0	30.5	3.15	3.7	3.8	90	93	13000	13375
150	14.3	8.0	31.9	3.15	3.8	3.9	93	96	14250	14750
185	16.0	8.0	33.6	3.15	4.0	4.0	97	100	15975	16325
240	18.4	8.0	36.0	3.15	4.1	4.2	103	106	18375	18850
300	20.4	8.0	38.0	3.15	4.3	4.4	108	111	20925	21300

Size	Max DC Resistance @ 20°C	Nominal Inductance	Capacitance	Conductor Short Circuit Current for 1 second	Current ratings			Voltage drop Per phase
					Buried Direct In the ground	In buried ducts	In air	
mm ²	Ohm/km	mH/km	μF/km	kA	Amps	Amps	Amps	V/A.Km
50	0.387	0.449	0.14	7.150	181	158	205	0.480
70	0.268	0.430	0.16	10.010	220	194	253	0.355
95	0.193	0.419	0.17	13.585	263	232	307	0.277
120	0.153	0.405	0.18	17.160	298	264	352	0.233
150	0.124	0.395	0.19	21.450	332	296	397	0.202
185	0.0991	0.384	0.21	26.455	374	335	453	0.175
240	0.0754	0.371	0.23	34.320	431	387	529	0.149
300	0.0601	0.358	0.25	42.900	482	435	599	0.131

Laying condition: Maximum conductor temperature 90°C, Ambient temperature 30°C. Underground temperature of soil 20°C, Depth of laying - 0.8m. Ground thermal resistivity 1.5 K.m/W, thermal resistivity of earthenware ducts 1.2 K.m/W.

Note: Area of copper wire considered is 16 mm² up to 120 mm², 25 mm² from 150 mm² up to 300 mm², 35 mm² from 400 mm² up to 630 mm².



ARMOURED THREE CORE CABLES

COPPER CONDUCTORS

IEC 60502-2
and BS 6622

$U_0/U (Um)=3.6/6(7.2) \text{ kV}$
 $3.8/6.6(7.2) \text{ kV}$



- | | |
|-------------------------------------|----------------------|
| 1. Conductor | 6. PP Filler |
| 2. Conductor Screen | 7. Bedding |
| 3. XLPE Insulation | 8. Steel Tape Armour |
| 4. Insulation Screen (Non-Metallic) | 9. Outer Sheath |
| 5. Insulation Screen (Metallic) | |

Size	Diameter of Conductor (Approx.)	Nominal Insulation Thickness	Diameter Over Insulation (Approx.)	Number & Nominal Thickness of steel Tape	Nominal Outer Sheath Thickness		Overall Diameter (Approx.)		Weight of Cable (Approx)	
					CUT	CUW	CUT	CUW	CUT	CUW
mm ²	mm	mm	mm		mm	mm	mm	mm	Kg/km	Kg/km
25	5.9	2.5	12.5	2x0.5	2.2	2.2	41	44	2500	2700
35	6.9	2.5	13.5	2x0.5	2.3	2.3	43	46	2900	3150
50	8.1	2.5	14.7	2x0.5	2.4	2.4	46	49	3450	3650
70	9.7	2.5	16.3	2x0.5	2.5	2.5	50	53	4275	4500
95	11.4	2.5	18.0	2x0.5	2.6	2.6	54	57	5250	5500
120	12.9	2.5	19.5	2x0.5	2.7	2.8	58	61	6175	6400
150	14.3	2.5	20.9	2x0.5	2.8	2.9	61	64	7150	7500
185	16.0	2.5	22.6	2x0.5	2.9	3.0	65	68	8475	8775
240	18.4	2.6	25.2	2x0.5	3.1	3.2	71	74	10550	10900
300	20.4	2.8	27.6	2x0.5	3.3	3.4	77	80	12875	13175

Size	Max DC Resistance @ 20°C	Nominal Inductance	Capacitance	Conductor Short Circuit Current for 1 second	Current ratings			Voltage drop Per phase
					Buried Direct In the ground	In buried ducts	In air	
mm ²	Ohm/km	mH/km	μF/km	kA	Amps	Amps	Amps	V/A.Km
25	0.727	0.363	0.26	3.575	129	112	143	0.810
35	0.524	0.344	0.29	5.005	154	134	172	0.600
50	0.387	0.333	0.32	7.150	181	158	205	0.458
70	0.268	0.322	0.36	10.010	220	194	253	0.334
95	0.193	0.316	0.39	13.585	263	232	307	0.257
120	0.153	0.309	0.43	17.160	298	264	352	0.215
150	0.124	0.303	0.47	21.450	332	296	397	0.185
185	0.0991	0.300	0.52	26.455	374	335	453	0.159
240	0.0754	0.293	0.56	34.320	431	387	529	0.124
300	0.0601	0.286	0.58	42.900	482	435	599	0.118

Laying condition: Maximum conductor temperature 90°C, Ambient temperature 30°C. Underground temperature of soil 20°C, Depth of laying - 0.8m. Ground thermal resistivity 1.5 K.m/W, thermal resistivity of earthenware ducts 1.2 K.m/W.

Note: Area of copper wire considered is 16 mm² up to 120 mm², 25 mm² from 150 mm² up to 300 mm², 35 mm² from 400 mm² up to 630 mm².



ARMOURED THREE CORE CABLES

COPPER CONDUCTORS

IEC 60502-2
and BS 6622

$U_0/U (U_m)=6 /10(12) \text{ kV}$
 $6.35/11(12) \text{ kV}$

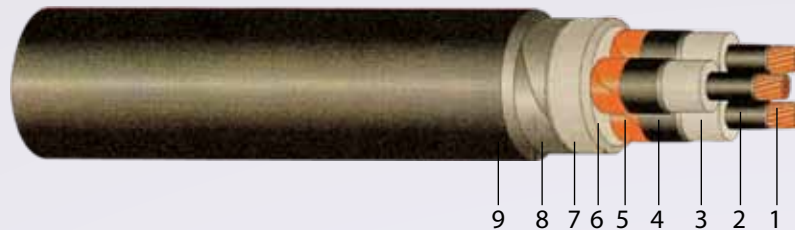

- | | |
|-------------------------------------|----------------------|
| 1. Conductor | 6. PP Filler |
| 2. Conductor Screen | 7. Bedding |
| 3. XLPE Insulation | 8. Steel Tape Armour |
| 4. Insulation Screen (Non-Metallic) | 9. Outer Sheath |
| 5. Insulation Screen (Metallic) | |

Size	Diameter of Conductor (Approx.)	Nominal Insulation Thickness	Diameter Over Insulation (Approx.)	Number & Nominal Thickness of steel Tape	Nominal Outer Sheath Thickness		Overall Diameter (Approx.)		Weight of Cable (Approx)	
					CUT	CUW	CUT	CUW	CUT	CUW
mm ²	mm	mm	mm	mm	mm	mm	mm	mm	Kg/km	Kg/km
25	5.9	3.4	14.3	2x0.5	2.3	2.4	45	48	2825	3100
35	6.9	3.4	15.3	2x0.5	2.4	2.5	48	51	3275	3525
50	8.1	3.4	16.5	2x0.5	2.5	2.6	50	54	3825	4050
70	9.7	3.4	18.1	2x0.5	2.6	2.7	54	58	4650	4950
95	11.4	3.4	19.8	2x0.5	2.7	2.8	58	61	5675	5900
120	12.9	3.4	21.3	2x0.5	2.9	2.9	62	65	6650	6850
150	14.3	3.4	22.7	2x0.5	3.0	3.0	65	68	7650	7975
185	16.0	3.4	24.4	2x0.5	3.1	3.1	69	72	9000	9300
240	18.4	3.4	26.8	2x0.5	3.3	3.3	76	78	11200	11450
300	20.4	3.4	28.8	2x0.5	3.4	3.5	80	83	13300	13575

Size	Max DC Resistance @ 20°C	Nominal Inductance	Capacitance	Conductor Short Circuit Current for 1 second	Current ratings			Voltage drop Per phase
					Buried Direct In the ground	In buried ducts	In air	
mm ²	Ohm/km	mH/km	μF/km	kA	Amps	Amps	Amps	V/A.Km
25	0.727	0.387	0.21	3.575	129	112	143	0.815
35	0.524	0.368	0.23	5.005	154	134	172	0.604
50	0.387	0.355	0.25	7.150	181	158	205	0.462
70	0.268	0.342	0.29	10.010	220	194	253	0.338
95	0.193	0.355	0.31	13.585	263	232	307	0.265
120	0.153	0.326	0.34	17.160	298	264	352	0.218
150	0.124	0.319	0.37	21.450	332	296	397	0.188
185	0.0991	0.313	0.40	26.455	374	335	453	0.161
240	0.0754	0.303	0.44	34.320	431	387	529	0.137
300	0.0601	0.297	0.48	42.900	482	435	599	0.120

Laying condition: Maximum conductor temperature 90°C, Ambient temperature 30°C. Underground temperature of soil 20°C, Depth of laying - 0.8m. Ground thermal resistivity 1.5 K.m/W, thermal resistivity of earthenware ducts 1.2 K.m/W.

Note: Area of copper wire considered is 16 mm² up to 120 mm², 25 mm² from 150 mm² up to 300 mm², 35 mm² from 400 mm² up to 630 mm².



ARMOURED THREE CORE CABLES

COPPER CONDUCTORS

IEC 60502-2
and BS 6622

$U_0/U (U_m)=8.7/15(17.5) \text{ kV}$

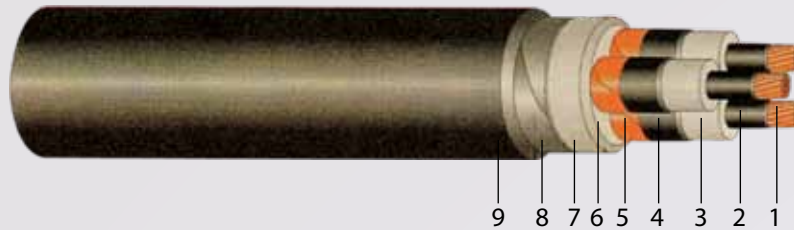

- | | |
|-------------------------------------|----------------------|
| 1. Conductor | 6. PP Filler |
| 2. Conductor Screen | 7. Bedding |
| 3. XLPE Insulation | 8. Steel Tape Armour |
| 4. Insulation Screen (Non-Metallic) | 9. Outer Sheath |

Size	Diameter of Conductor (Approx.)	Nominal Insulation Thickness	Diameter Over Insulation (Approx.)	Number & Nominal Thickness of steel Tape	Nominal Outer Sheath Thickness		Overall Diameter (Approx.)		Weight of Cable (Approx)	
					CUT	CUW	CUT	CUW	CUT	CUW
mm ²	mm	mm	mm		mm	mm	mm	mm	Kg/km	Kg/km
25	5.9	4.5	16.5	2x0.5	2.5	2.5	50	53	3300	3500
35	6.9	4.5	17.5	2x0.5	2.6	2.6	53	56	3750	4000
50	8.1	4.5	18.7	2x0.5	2.7	2.7	56	59	4325	4525
70	9.7	4.5	20.3	2x0.5	2.8	2.8	60	63	5200	5425
95	11.4	4.5	22.0	2x0.5	2.9	3.0	64	67	6250	6550
120	12.9	4.5	23.5	2x0.5	3.0	3.1	67	70	725	7500
150	14.3	4.5	24.9	2x0.5	3.1	3.2	70	74	8250	8650
185	16.0	4.5	26.6	2x0.5	3.3	3.3	75	78	9800	1050
240	18.4	4.5	29.0	2x0.5	3.4	3.5	81	84	11900	12100
300	20.4	4.5	31.0	2x0.8	3.6	3.7	87	90	14800	15150

Size	Max DC Resistance @ 20°C	Nominal Inductance	Capacitance	Conductor Short Circuit Current for 1 second	Current ratings			Voltage drop Per phase
					Buried Direct In the ground	In buried ducts	In air	
mm ²	Ohm/km	mH/km	μF/km	kA	Amps	Amps	Amps	V/A.Km
25	0.727	0.413	0.17	3.575	129	112	143	0.820
35	0.524	0.394	0.19	5.005	154	134	172	0.609
50	0.387	0.379	0.21	7.150	181	158	205	0.46
70	0.268	0.364	0.23	10.010	220	194	253	0.342
95	0.193	0.356	0.25	13.585	263	232	307	0.265
120	0.153	0.346	0.27	17.160	298	264	352	0.222
150	0.124	0.338	0.29	21.450	332	296	397	0.191
185	0.0991	0.330	0.32	26.455	374	335	453	0.165
240	0.0754	0.321	0.35	34.320	431	387	529	0.140
300	0.0601	0.312	0.39	42.900	482	435	599	0.123

Laying condition: Maximum conductor temperature 90°C, Ambient temperature 30°C. Underground temperature of soil 20°C, Depth of laying - 0.8m. Ground thermal resistivity 1.5 K.m/W, thermal resistivity of earthenware ducts 1.2 K.m/W.

Note: Area of copper wire considered is 16 mm² up to 120 mm², 25 mm² from 150 mm² up to 300 mm², 35 mm² from 400 mm² up to 630 mm².



ARMoured THREE CORE CABLES

COPPER CONDUCTORS

IEC 60502-2
and BS 6622

$U_0/U (U_m)=12/20(24) \text{ kV}$
 $12.7/22(24) \text{ kV}$

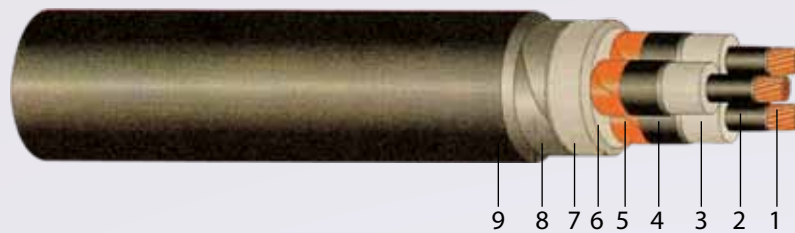

- | | |
|-------------------------------------|----------------------|
| 1. Conductor | 6. PP Filler |
| 2. Conductor Screen | 7. Bedding |
| 3. XLPE Insulation | 8. Steel Tape Armour |
| 4. Insulation Screen (Non-Metallic) | 9. Outer Sheath |
| 5. Insulation Screen (Metallic) | |

Size	Diameter of Conductor (Approx.)	Nominal Insulation Thickness	Diameter Over Insulation (Approx.)	Number & Nominal Thickness of steelTape	Nominal Outer Sheath Thickness		Overall Diameter (Approx.)		Weight of Cable (Approx)	
					CUT	CUW	CUT	CUW	CUT	CUW
mm ²	mm	mm	mm		mm	mm	mm	mm	Kg/km	Kg/km
25	5.9	6.0	19.5	2x0.5	2.7	2.8	58	61	4000	4225
35	6.9	5.5	19.5	2x0.5	2.7	2.8	58	61	4225	4500
50	8.1	5.5	20.7	2x0.5	2.8	2.9	61	64	4825	5050
70	9.7	5.5	22.3	2x0.5	3	3.0	64	67	5800	5925
95	11.4	5.5	24.0	2x0.5	3.1	3.1	69	72	6825	7000
120	12.9	5.5	25.5	2x0.5	3.2	3.2	66	75	7900	8100
150	14.3	5.5	26.9	2x0.5	3.3	3.4	76	79	9000	9300
185	16.0	5.5	28.6	2x0.5	3.4	3.5	80	83	10400	10700
240	18.4	5.5	31.0	2x0.5	3.6	3.7	87	90	13400	13700
300	20.4	5.5	33.0	2x0.8	3.8	3.9	92	95	15600	15900

Size	Max DC Resistance @ 20°C	Nominal Inductance	Capacitance	Conductor Short Circuit Current for 1 second	Current ratings			Voltage drop Per phase
					Buried Direct In the ground	In buried ducts	In air	
mm ²	Ohm/km	mH/km	µF/km	kA	Amps	Amps	Amps	V/A.Km
25	0.727	0.444	0.14	3.575	129	112	143	0.825
35	0.524	0.415	0.16	5.005	154	134	172	0.613
50	0.387	0.399	0.18	7.150	181	158	205	0.47
70	0.268	0.382	0.20	10.010	220	194	253	0.346
95	0.193	0.373	0.21	13.585	263	232	307	0.268
120	0.153	0.362	0.23	17.160	298	264	352	0.225
150	0.124	0.353	0.25	21.450	332	296	397	0.194
185	0.0991	0.345	0.27	26.455	374	335	453	0.167
240	0.0754	0.335	0.30	34.320	431	387	529	0.142
300	0.0601	0.320	0.33	42.900	482	435	599	0.124

Laying condition: Maximum conductor temperature 90°C, Ambient temperature 30°C. Underground temperature of soil 20°C, Depth of laying - 0.8m. Ground thermal resistivity 1.5 K.m/W, thermal resistivity of earthenware ducts 1.2 K.m/W.

Note: Area of copper wire considered is 16 mm² up to 120 mm², 25 mm² from 150 mm² up to 300 mm², 35 mm² from 400 mm² up to 630 mm².



ARMoured THREE CORE CABLES

COPPER CONDUCTORS

IEC 60502-2
and BS 6622

$U_0/U (U_m)=18/30(36) \text{ kV}$
 $19/33(36) \text{ kV}$



- | | |
|-------------------------------------|----------------------|
| 1. Conductor | 6. PP Filler |
| 2. Conductor Screen | 7. Bedding |
| 3. XLPE Insulation | 8. Steel Tape Armour |
| 4. Insulation Screen (Non-Metallic) | 9. Outer Sheath |
| 5. Insulation Screen (Metallic) | |

Size	Diameter of Conductor (Approx.)	Nominal Insulation Thickness	Diameter Over Insulation (Approx.)	Number & Nominal Thickness of steel Tape	Nominal Outer Sheath Thickness		Overall Diameter (Approx.)		Weight of Cable (Approx)	
					CUT	CUW	CUT	CUW	CUT	CUW
mm ²	mm	mm	mm		mm	mm	mm	mm	Kg/km	Kg/km
50	8.1	8.0	25.7	2x0.5	3.2	3.3	73	76	6300	6500
70	9.7	8.0	27.3	2x0.5	3.3	3.4	77	80	7300	7550
95	11.4	8.0	29.0	2x0.5	3.5	3.5	81	84	8500	8650
120	12.9	8.0	30.5	2x0.5	3.6	3.7	86	89	10325	10600
150	14.3	8.0	31.9	2x0.5	3.7	3.8	89	92	11450	11850
185	16.0	8.0	33.6	2x0.8	3.9	3.9	93	96	13050	13325
240	18.4	8.0	36.0	2x0.8	4.0	4.1	99	102	15300	15600
300	20.4	8.0	38.0	2x0.8	4.2	4.2	104	106	17650	17900

Size	Max DC Resistance @ 20°C	Nominal Inductance	Capacitance	Conductor Short Circuit Current for 1 second	Current ratings			Voltage drop Per phase
					Buried Direct In the ground	In buried ducts	In air	
mm ²	Ohm/km	mH/km	μF/km	kA	Amps	Amps	Amps	V/A.Km
50	0.387	0.449	0.14	7.150	181	158	205	0.480
70	0.268	0.430	0.16	10.010	220	194	253	0.355
95	0.193	0.419	0.17	13.585	263	232	307	0.277
120	0.153	0.405	0.18	17.160	298	264	352	0.233
150	0.124	0.395	0.19	21.450	332	296	397	0.202
185	0.0991	0.384	0.21	26.455	374	335	453	0.175
240	0.0754	0.371	0.23	34.320	431	387	529	0.149
300	0.0601	0.358	0.25	42.900	482	435	599	0.131

Laying condition: Maximum conductor temperature 90°C, Ambient temperature 30°C. Underground temperature of soil 20°C, Depth of laying - 0.8m. Ground thermal resistivity 1.5 K.m/W, thermal resistivity of earthenware ducts 1.2 K.m/W.

Note: Area of copper wire considered is 16 mm² up to 120 mm², 25 mm² from 150 mm² up to 300 mm², 35 mm² from 400 mm² up to 630 mm².



UNARMoured SINGLE CORE CABLES

ALUMINIUM CONDUCTORS

IEC 60502-2
and BS 6622

$U_0/U (U_m)=3.6/6(7.2) \text{ kV}$
 $3.8/6.6(7.2) \text{ kV}$

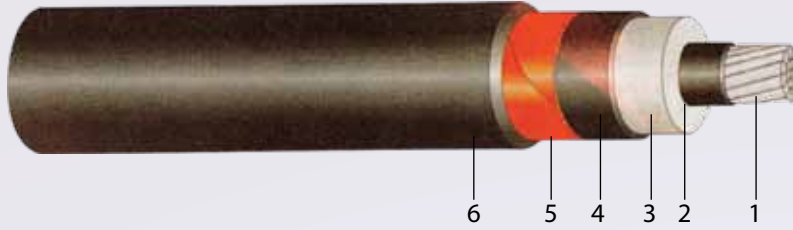

- 1. Conductor
- 2. Conductor Screen
- 3. XLPE Insulation
- 4. Insulation Screen (Non-metallic)
- 5. Insulation Screen (Metallic)
- 6. Outer Sheath

Size	Diameter of Conductor (Approx.)	Nominal Insulation Thickness	Diameter Over Insulation (Approx.)	Nominal Outer Sheath Thickness		Overall Diameter (Approx.)		Weight of Cable (Approx)	
				CUT	CUW	CUT	CUW	CUT	CUW
mm ²	mm	mm	mm	mm	mm	mm	mm	Kg/km	Kg/km
25	6.0	2.5	12.6	1.8	1.8	18	20	375	550
35	7.1	2.5	13.7	1.8	1.8	19	21	425	550
50	8.3	2.5	14.9	1.8	1.8	21	22	500	675
70	9.7	2.5	16.3	1.8	1.8	22	24	600	750
95	11.55	2.5	18.15	1.8	1.8	24	26	700	850
120	12.95	2.5	19.55	1.8	1.8	26	27	800	925
150	14.3	2.5	20.9	1.8	1.8	27	29	925	1125
185	15.9	2.5	22.5	1.8	1.9	29	30	1050	1275
240	18.4	2.6	25.2	1.9	1.9	31	33	1300	1500
300	20.5	2.8	27.7	2.0	2.0	34	36	1550	1750
400	24.0	3.0	31.6	2.1	2.2	38	40	1925	2250
500	27.0	3.2	35.0	2.2	2.3	42	44	2350	2675
630	30.4	3.2	38.4	2.3	2.4	46	48	2900	3200

SIZE	Max DC Resistance @ 20°C	Inductance		Capacitance	Conductor Short Circuit Current for 1 second	Current ratings						Voltage drop per phase	
		Trefoil	Flat			Buried Direct In the ground		In single-way ducts		In air			
						Trefoil	Flat Spaced	Trefoil ducts	Flat Touching ducts	Trefoil	Flat Touching		Flat Spaced
mm ²	Ohm/km	mH/km	mH/km	µF/km	kA	Amps	Amps	Amps	Amps	Amps	Amps	Amps	V/A.Km
25	1.20	0.444	0.760	0.26	2.360	108	112	102	103	127	130	153	1.314
35	0.868	0.426	0.745	0.29	3.304	129	134	122	123	154	157	185	0.971
50	0.641	0.412	0.726	0.31	4.720	152	157	144	146	184	189	222	0.735
70	0.443	0.388	0.694	0.37	6.608	186	192	176	178	230	236	278	0.528
95	0.320	0.378	0.679	0.39	8.968	221	229	210	213	280	287	338	0.400
120	0.253	0.364	0.660	0.44	11.328	252	260	240	242	324	332	391	0.328
150	0.206	0.354	0.645	0.48	14.160	281	288	267	271	368	376	440	0.279
185	0.164	0.343	0.630	0.52	17.464	317	324	303	307	424	432	504	0.234
240	0.125	0.332	0.611	0.56	22.656	367	373	351	356	502	511	593	0.192
300	0.100	0.324	0.596	0.58	28.320	414	419	397	402	577	586	677	0.165
400	0.0778	0.313	0.573	0.61	37.760	470	466	451	457	673	676	769	0.141
500	0.0605	0.306	0.564	0.64	47.200	528	519	512	518	770	767	857	0.122
630	0.0469	0.296	0.548	0.71	59.472	599	582	583	590	896	885	980	0.107

Laying condition: Maximum conductor temperature 90°C, Ambient temperature 30°C. Underground temperature of soil 20°C, Depth of laying - 0.8m. Ground thermal resistivity 1.5 K.m/W, thermal resistivity of earthenware ducts 1.2 K.m/W.

Note: Area of copper wire considered is 16 mm² up to 120 mm², 25 mm² from 150 mm² up to 300 mm², 35 mm² from 400 mm² up to 630 mm².



UNARMoured SINGLE CORE CABLES

ALUMINIUM CONDUCTORS

IEC 60502-2
and BS 6622

$U_0/U (U_m)=6 /10(12) \text{ kV}$
 $6.35/11(12) \text{ kV}$

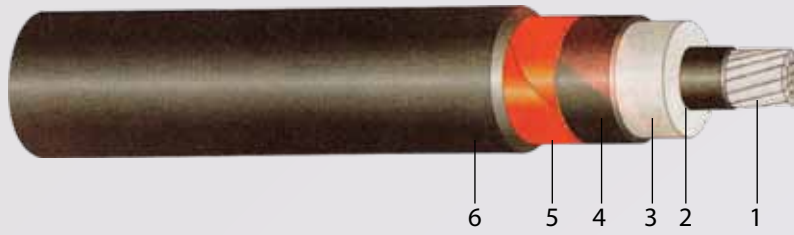

1. Conductor
2. Conductor Screen
3. XLPE Insulation
4. Insulation Screen (Non-metallic)
5. Insulation Screen (Metallic)
6. Outer Sheath

Size	Diameter of Conductor (Approx.)	Nominal Insulation Thickness	Diameter Over Insulation (Approx.)	Nominal Outer Sheath Thickness		Overall Diameter (Approx.)		Weight of Cable (Approx.)	
				CUT	CUW	CUT	CUW	CUT	CUW
mm ²	mm	mm	mm	mm	mm	mm	mm	Kg/km	Kg/km
25	6.0	3.4	14.4	1.8	1.8	20	22	450	625
35	7.1	3.4	15.5	1.8	1.8	21	23	500	650
50	8.3	3.4	16.7	1.8	1.8	23	24	575	700
70	9.7	3.4	18.1	1.8	1.8	24	26	675	800
95	11.55	3.4	19.95	1.8	1.8	26	28	800	900
120	12.95	3.4	21.35	1.8	1.8	28	29	900	1000
150	14.3	3.4	22.7	1.8	1.9	29	31	1000	1200
185	15.9	3.4	24.3	1.9	1.9	31	32	1150	1350
240	18.4	3.4	26.8	2.0	2.0	33	35	1400	1600
300	20.5	3.4	28.9	2.0	2.1	35	37	1625	1850
400	24.0	3.4	32.4	2.1	2.2	39	41	1975	2300
500	27.0	3.4	35.4	2.2	2.3	42	44	2375	2700
630	30.4	3.4	38.8	2.3	2.4	46	48	2875	3250

SIZE	Max DC Resistance @ 20°C	Inductance		Capacitance	Conductor Short Circuit Current for 1 second	Current ratings							Voltage drop per phase
		Trefoil	Flat			Buried Direct In the ground		In single-way ducts		In air			
						Trefoil	Flat Spaced	Trefoil ducts	Flat Touching ducts	Trefoil	Flat Touching	Flat Spaced	
mm ²	Ohm/km	mH/km	mH/km	µF/km	kA	Amps	Amps	Amps	Amps	Amps	Amps	Amps	V/A.Km
25	1.20	0.460	0.770	0.21	2.360	108	112	102	103	127	130	153	1.318
35	0.868	0.440	0.751	0.23	0.304	129	134	122	123	154	157	185	0.973
50	0.641	0.424	0.731	0.25	4.720	152	157	144	146	184	189	222	0.737
70	0.443	0.401	0.700	0.29	6.608	186	192	176	178	230	236	278	0.530
95	0.320	0.383	0.681	0.31	8.968	221	229	210	213	280	287	338	0.401
120	0.253	0.376	0.666	0.34	11.328	252	260	240	242	324	332	391	0.331
150	0.206	0.364	0.650	0.37	14.160	281	288	267	271	368	376	440	0.280
185	0.164	0.354	0.635	0.40	17.464	317	324	303	307	424	432	504	0.236
240	0.125	0.341	0.615	0.45	22.656	367	373	351	356	502	511	593	0.194
300	0.100	0.329	0.599	0.49	28.320	414	419	397	402	577	586	677	0.166
400	0.0778	0.318	0.580	0.55	37.760	470	466	451	457	673	676	769	0.142
500	0.0605	0.308	0.565	0.60	47.200	528	519	512	518	770	767	857	0.123
630	0.0469	0.299	0.549	0.68	59.472	599	582	583	590	896	885	980	0.108

Laying condition: Maximum conductor temperature 90°C, Ambient temperature 30°C. Underground temperature of soil 20°C, Depth of laying - 0.8m. Ground thermal resistivity 1.5 K.m/W, thermal resistivity of earthenware ducts 1.2 K.m/W.

Note: Area of copper wire considered is 16 mm² up to 120 mm², 25 mm² from 150 mm² up to 300 mm², 35 mm² from 400 mm² up to 630 mm².



UNARMoured SINGLE CORE CABLES

ALUMINIUM CONDUCTORS

IEC 60502-2
and BS 6622

$U_0/U (U_m)=8.7/15(17.5) \text{ kV}$

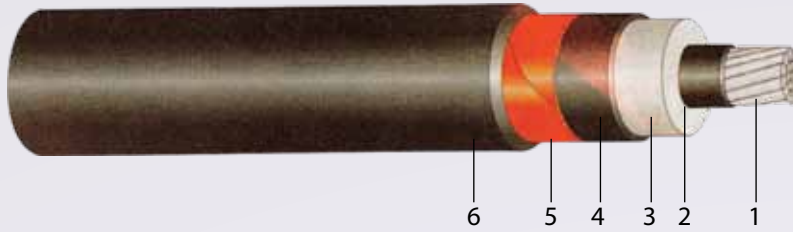

1. Conductor
2. Conductor Screen
3. XLPE Insulation
4. Insulation Screen (Non-metallic)
5. Insulation Screen (Metallic)
6. Outer Sheath

Size	Diameter of Conductor (Approx.)	Nominal Insulation Thickness	Diameter Over Insulation (Approx.)	Nominal Outer Sheath Thickness		Overall Diameter (Approx.)		Weight of Cable (Approx)	
				CUT	CUW	CUT	CUW	CUT	CUW
mm ²	mm	mm	mm	mm	mm	mm	mm	Kg/km	Kg/km
25	6.0	4.5	16.6	1.8	1.8	22	24	525	650
35	7.1	4.5	17.7	1.8	1.8	24	25	600	725
50	8.3	4.5	18.9	1.8	1.8	25	26	675	800
70	9.7	4.5	20.3	1.8	1.8	27	28	775	875
95	11.55	4.5	22.15	1.8	1.8	28	30	900	1000
120	12.95	4.5	23.55	1.9	1.9	30	31	1025	1125
150	14.3	4.5	24.9	1.9	1.9	31	33	1150	1325
185	15.9	4.5	26.5	2.0	2.0	33	34	1300	1500
240	18.4	4.5	29.0	2.0	2.1	36	37	1550	1750
300	20.5	4.5	31.1	2.1	2.1	38	39	1775	1975
400	24.0	4.5	34.6	2.2	2.3	42	43	2150	2450
500	27.0	4.5	37.6	2.3	2.4	45	47	2550	2850
630	30.4	4.5	41.0	2.4	2.5	49	51	3125	3450

SIZE	Max DC Resistance @ 20°C	Inductance		Capacitance	Conductor Short Circuit Current for 1 second	Current ratings						Voltage drop per phase	
		Trefoil	Flat			Buried Direct In the ground		In single -way ducts		In air			
						Trefoil	Flat Spaced	Trefoil ducts	Flat Touching ducts	Trefoil	Flat Touching		Flat Spaced
mm ²	Ohm/km	mH/km	mH/km	μF/km	kA	Amps	Amps	Amps	Amps	Amps	Amps	Amps	V/A.Km
25	1.20	0.470	0.780	0.17	2.360	108	112	102	103	127	130	153	1.320
35	0.868	0.456	0.758	0.19	0.304	129	134	122	123	154	157	185	0.976
50	0.641	0.440	0.738	0.20	4.720	152	157	144	146	184	189	222	0.74
70	0.443	0.415	0.706	0.23	6.608	186	192	176	178	230	236	278	0.533
95	0.320	0.402	0.690	0.25	8.968	221	229	210	213	280	287	338	0.404
120	0.253	0.389	0.672	0.27	11.328	252	260	240	242	324	332	391	0.333
150	0.206	0.377	0.656	0.29	14.160	281	288	267	271	368	376	440	0.283
185	0.164	0.366	0.641	0.32	17.464	317	324	303	307	424	432	504	0.238
240	0.125	0.352	0.621	0.35	22.656	367	373	351	356	502	511	593	0.196
300	0.100	0.340	0.605	0.39	28.320	414	419	397	402	577	586	677	0.168
400	0.0778	0.327	0.585	0.43	37.760	470	466	451	457	673	676	769	0.144
500	0.0605	0.318	0.570	0.48	47.200	528	519	512	518	770	767	857	0.125
630	0.0469	0.307	0.554	0.53	59.472	599	582	583	590	896	885	980	0.109

Laying condition: Maximum conductor temperature 90°C, Ambient temperature 30°C. Underground temperature of soil 20°C, Depth of laying - 0.8m. Ground thermal resistivity 1.5 K.m/W, thermal resistivity of earthenware ducts 1.2 K.m/W.

Note: Area of copper wire considered is 16 mm² up to 120 mm², 25 mm² from 150 mm² up to 300 mm², 35 mm² from 400 mm² up to 630 mm².



UNARMoured SINGLE CORE CABLES

ALUMINIUM CONDUCTORS

IEC 60502-2
and BS 6622

$U_0/U (U_m)=12/20(24) \text{ kV}$
 $12.7/22(24) \text{ kV}$

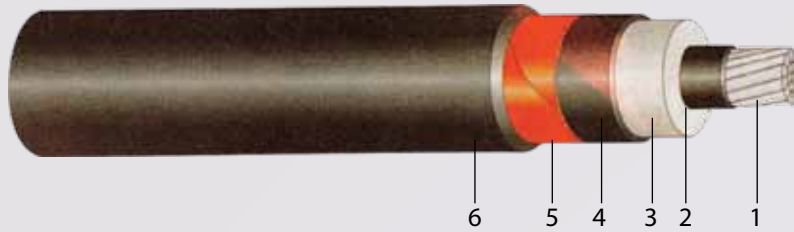

1. Conductor
2. Conductor Screen
3. XLPE Insulation
4. Insulation Screen (Non-metallic)
5. Insulation Screen (Metallic)
6. Outer Sheath

Size	Diameter of Conductor (Approx.)	Nominal Insulation Thickness	Diameter Over Insulation (Approx.)	Nominal Outer Sheath Thickness		Overall Diameter (Approx.)		Weight of Cable (Approx.)	
				CUT	CUW	CUT	CUW	CUT	CUW
mm ²	mm	mm	mm	mm	mm	mm	mm	Kg/km	Kg/km
25	6.0	6.0	19.6	1.8	1.8	26	27	675	775
35	7.1	5.5	19.7	1.8	1.8	26	27	700	800
50	8.3	5.5	20.9	1.8	1.8	27	29	775	875
70	9.7	5.5	22.3	1.8	1.9	29	30	875	1000
95	11.55	5.5	24.15	1.9	1.9	31	32	1025	1125
120	12.95	5.5	25.55	1.9	2.0	32	34	1125	1250
150	14.3	5.5	26.9	2.0	2.0	34	35	1250	1450
185	15.9	5.5	28.6	2.0	2.1	35	37	1425	1625
240	18.4	5.5	31.0	2.1	2.1	38	39	1675	1875
300	20.5	5.5	33.1	2.2	2.2	40	42	1925	2125
400	24.0	5.5	36.6	2.3	2.3	44	46	2300	2600
500	27.0	5.5	39.6	2.4	2.4	47	49	2800	3050
630	30.4	5.5	43.0	2.5	2.5	51	53	3325	3600

SIZE	Max DC Resistance @ 20°C	Inductance		Capacitance	Conductor Short Circuit Current for 1 second	Current ratings							Voltage drop per phase
		Trefoil	Flat			Buried Direct In the ground		In single -way ducts		In air			
						Trefoil	Flat Spaced	Trefoil ducts	Flat Touching ducts	Trefoil	Flat Touching	Flat Spaced	
mm ²	Ohm/km	mH/km	mH/km	µF/km	kA	Amps	Amps	Amps	Amps	Amps	Amps	Amps	V/A.Km
25	1.20	0.497	0.792	0.14	2.360	108	112	102	103	127	130	153	1.324
35	0.868	0.468	0.763	0.16	0.304	129	134	122	123	154	157	185	0.976
50	0.641	0.453	0.744	0.18	4.720	152	157	144	146	184	189	222	0.743
70	0.443	0.426	0.712	0.20	6.608	186	192	176	178	230	236	278	0.535
95	0.320	0.414	0.696	0.21	8.968	221	229	210	213	280	287	338	0.407
120	0.253	0.399	0.677	0.23	11.328	252	260	240	242	324	332	391	0.335
150	0.206	0.388	0.662	0.25	14.160	281	288	267	271	368	376	440	0.285
185	0.164	0.375	0.646	0.27	17.464	317	324	303	307	424	432	504	0.24
240	0.125	0.361	0.626	0.30	22.656	367	373	351	356	502	511	593	0.197
300	0.100	0.350	0.610	0.33	28.320	414	419	397	402	577	586	677	0.17
400	0.0778	0.336	0.590	0.37	37.760	470	466	451	457	673	676	769	0.146
500	0.0605	0.326	0.575	0.40	47.200	528	519	512	518	770	767	857	0.126
630	0.0469	0.315	0.558	0.45	59.472	599	582	583	590	896	885	980	0.111

Laying condition: Maximum conductor temperature 90°C, Ambient temperature 30°C. Underground temperature of soil 20°C, Depth of laying - 0.8m. Ground thermal resistivity 1.5 K.m/W, thermal resistivity of earthenware ducts 1.2 K.m/W.

Note: Area of copper wire considered is 16 mm² up to 120 mm², 25 mm² from 150 mm² up to 300 mm², 35 mm² from 400 mm² up to 630 mm².



UNARMoured SINGLE CORE CABLES

ALUMINIUM CONDUCTORS

IEC 60502-2
and BS 6622

$U_0/U (U_m)=18/30(36) \text{ kV}$
 $19/33(36) \text{ kV}$

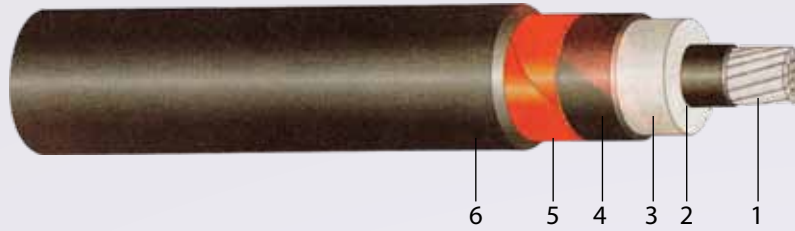

- 1. Conductor
- 2. Conductor Screen
- 3. XLPE Insulation
- 4. Insulation Screen (Non-metallic)
- 5. Insulation Screen (Metallic)
- 6. Outer Sheath

Size	Diameter of Conductor (Approx.)	Nominal Insulation Thickness	Diameter Over Insulation (Approx.)	Nominal Outer Sheath Thickness		Overall Diameter (Approx.)		Weight of Cable (Approx.)	
				CUT	CUW	CUT	CUW	CUT	CUW
mm ²	mm	mm	mm	mm	mm	mm	mm	Kg/km	Kg/km
50	8.3	8.0	25.9	1.9	2.0	32	34	1025	1150
70	9.7	8.0	27.3	2.0	2.0	34	35	1150	1275
95	11.55	8.0	29.15	2	2.1	36	38	1325	1450
120	12.95	8.0	30.55	2.1	2.1	38	39	1450	1550
150	14.3	8.0	31.9	2.1	2.2	39	40	1575	1800
185	15.9	8.0	33.5	2.2	2.2	41	42	1750	1950
240	18.4	8.0	36.0	2.3	2.3	43	45	2050	2225
300	20.5	8.0	38.1	2.3	2.4	46	47	2300	2500
400	24.0	8.0	41.6	2.5	2.5	50	51	2775	3050
500	27.0	8.0	44.6	2.5	2.6	53	54	3200	3500
630	30.4	8.0	48.0	2.7	2.7	56	58	3800	4050

SIZE	Max DC Resistance @ 20°C	Inductance		Capacitance	Conductor Short Circuit Current for 1 second	Current ratings							Voltage drop per phase
		Trefoil	Flat			Buried Direct In the ground		In single -way ducts		In air			
						Trefoil	Flat Spaced	Trefoil ducts	Flat Touching ducts	Trefoil	Flat Touching	Flat Spaced	
mm ²	Ohm/km	mH/km	mH/km	μF/km	kA	Amps	Amps	Amps	Amps	Amps	Amps	Amps	V/A.Km
50	0.641	0.487	0.761	0.14	4.720	152	157	144	146	184	189	222	0.749
70	0.443	0.459	0.728	0.16	6.608	186	192	176	178	230	236	278	0.541
95	0.320	0.446	0.712	0.17	8.968	221	229	210	213	280	287	338	0.413
120	0.253	0.430	0.693	0.18	11.328	252	260	240	242	324	332	391	0.341
150	0.206	0.417	0.677	0.19	14.160	281	288	267	271	368	376	440	0.291
185	0.164	0.404	0.661	0.21	17.464	317	324	303	307	424	432	504	0.245
240	0.125	0.388	0.641	0.23	22.656	367	373	351	356	502	511	593	0.203
300	0.100	0.375	0.624	0.25	28.320	414	419	397	402	577	586	677	0.175
400	0.0778	0.360	0.604	0.27	37.760	470	466	451	457	673	676	769	0.15
500	0.0605	0.349	0.589	0.30	47.200	528	519	512	518	770	767	857	0.131
630	0.0469	0.336	0.571	0.33	59.472	599	582	583	590	896	885	980	0.115

Laying condition: Maximum conductor temperature 90°C, Ambient temperature 30°C. Underground temperature of soil 20°C, Depth of laying - 0.8m. Ground thermal resistivity 1.5 K.m/W, thermal resistivity of earthenware ducts 1.2 K.m/W.

Note: Area of copper wire considered is 16 mm² up to 120 mm², 25 mm² from 150 mm² up to 300 mm², 35 mm² from 400 mm² up to 630 mm².



ARMOURED SINGLE CORE CABLES

ALUMINIUM CONDUCTORS

IEC 60502-2
and BS 6622

$U_0/U (U_m)=3.6/6(7.2) \text{ kV}$
 $3.8/6.6(7.2) \text{ kV}$

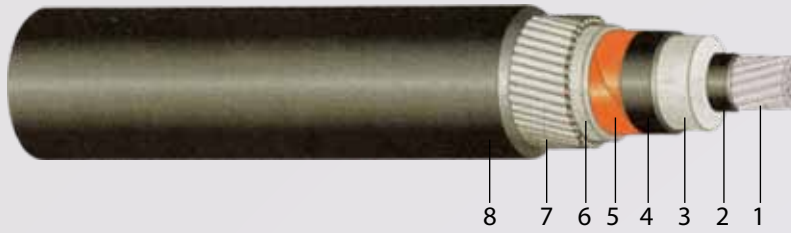

- | | |
|-------------------------------------|---------------------------------|
| 1. Conductor | 5. Insulation Screen (Metallic) |
| 2. Conductor Screen | 6. Bedding |
| 3. XLPE Insulation | 7. Aluminium Wire Armour |
| 4. Insulation Screen (Non-metallic) | 8. Outer Sheath |

Size	Diameter of Conductor (Approx.)	Nominal Insulation Thickness	Diameter Over Insulation (Approx.)	Nominal Diameter of Aluminium Wire	Nominal Outer Sheath Thickness		Overall Diameter (Approx.)		Weight of Cable (Approx)	
				CUT/CUW	CUT	CUW	CUT	CUW	CUT	CUW
mm ²	mm	mm	mm	mm	mm	mm	mm	mm	Kg/km	Kg/km
25	6.0	2.5	12.6	1.6	1.8	1.8	24	26	750	950
35	7.1	2.5	13.7	1.6	1.8	1.8	25	27	825	1025
50	8.3	2.5	14.9	1.6	1.8	1.8	27	28	900	1100
70	9.7	2.5	16.3	1.6	1.8	1.8	28	29	975	1225
95	11.55	2.5	18.15	1.6	1.9	1.9	30	31	1175	1350
120	12.95	2.5	19.55	1.6	1.9	1.9	31	33	1300	1500
150	14.3	2.5	20.9	2.0	2.0	2.0	33	35	1400	1775
185	15.9	2.5	22.5	2.0	2.0	2.1	35	37	1650	2000
240	18.4	2.6	25.2	2.0	2.1	2.2	38	40	2000	2325
300	20.5	2.8	27.7	2.0	2.2	2.2	41	42	2325	2625
400	24.0	3.0	31.6	2/2.5	2.3	2.4	46	48	2725	3400
500	27.0	3.2	35.0	2.5	2.5	2.5	50	52	3475	3900
630	30.4	3.2	38.4	2.5	2.6	2.6	54	56	4100	4550

Size	Max DC Resistance @ 20°C	Inductance		Capacitance	Conductor Short Circuit Current for 1 second	Current ratings							Voltage drop per phase
		Trefoil	Flat			Buried Direct In the ground		In single-way ducts		In air			
						Trefoil	Flat Spaced	Trefoil ducts	Flat Touching ducts	Trefoil	Flat Touching	Flat Spaced	
mm ²	Ohm/km	mH/km	mH/km	µF/km	kA	Amps	Amps	Amps	Amps	Amps	Amps	Amps	V/A.Km
25	1.20	0.473	0.785	0.26	2.360	107	111	101	103	126	128	147	1.323
35	0.868	0.461	0.760	0.29	3.304	127	131	121	123	152	155	178	0.979
50	0.641	0.444	0.735	0.31	4.720	150	154	142	145	182	185	212	0.743
70	0.443	0.418	0.708	0.37	6.608	182	187	174	177	226	230	263	0.535
95	0.320	0.406	0.692	0.39	8.968	217	221	207	210	275	279	317	0.407
120	0.253	0.392	0.637	0.44	11.328	246	249	235	239	317	321	363	0.336
150	0.206	0.380	0.658	0.48	14.160	274	274	262	265	360	361	405	0.286
185	0.164	0.369	0.642	0.52	17.464	309	305	297	298	413	411	457	0.241
240	0.125	0.356	0.623	0.56	22.656	355	344	342	342	485	478	526	0.198
300	0.100	0.346	0.608	0.58	28.320	397	378	383	382	552	539	587	0.17
400	0.0778	0.334	0.589	0.61	37.760	448	416	434	430	638	613	656	0.146
500	0.0605	0.327	0.576	0.64	47.200	494	446	482	470	724	677	718	0.127
630	0.0469	0.315	0.558	0.71	59.472	549	484	537	521	824	755	792	0.112

Laying condition: Maximum conductor temperature 90°C, Ambient temperature 30°C. Underground temperature of soil 20°C, Depth of laying - 0.8m. Ground thermal resistivity 1.5 K.m/W, thermal resistivity of earthenware ducts 1.2 K.m/W.

Note: Area of copper wire considered is 16 mm² up to 120 mm², 25 mm² from 150 mm² up to 300 mm², 35 mm² from 400 mm² up to 630 mm².



ARMOURED SINGLE CORE CABLES

ALUMINIUM CONDUCTORS

IEC 60502-2
and BS 6622

U₀/U (U_m)=6 /10(12) kV
6.35/11(12) kV

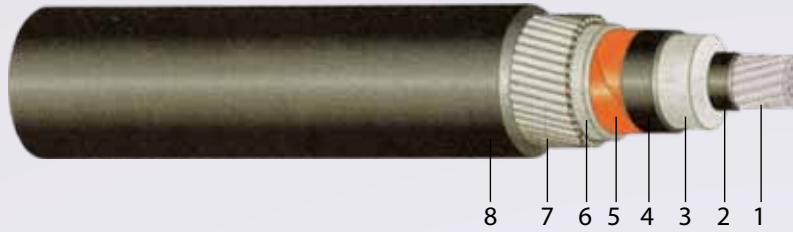

- | | |
|-------------------------------------|---------------------------------|
| 1. Conductor | 5. Insulation Screen (Metallic) |
| 2. Conductor Screen | 6. Bedding |
| 3. XLPE Insulation | 7. Aluminium Wire Armour |
| 4. Insulation Screen (Non-metallic) | 8. Outer Sheath |

Size	Diameter of Conductor (Approx.)	Nominal Insulation Thickness	Diameter Over Insulation (Approx.)	Nominal Diameter of Aluminium Wire	Nominal Outer Sheath Thickness		Overall Diameter (Approx.)		Weight of Cable (Approx)	
				CUT/CUW	CUT	CUW	CUT	CUW	CUT	CUW
mm ²	mm	mm	mm	mm	mm	mm	mm	mm	Kg/km	Kg/km
25	6.0	3.4	14.4	1.6	1.8	1.8	26	28	850	1050
35	7.1	3.4	15.5	1.6	1.8	1.8	27	29	925	1100
50	8.3	3.4	16.7	1.6	1.8	1.9	29	30	975	1225
70	9.7	3.4	18.1	1.6	1.9	1.9	30	31	1100	1350
95	11.55	3.4	19.95	1.6	1.9	2.0	32	33	1300	1475
120	12.95	3.4	21.35	1.6/2	2.0	2.0	34	36	1400	1700
150	14.3	3.4	22.7	2.0	2.1	2.1	36	37	1600	1925
185	15.9	3.4	24.3	2.0	2.1	2.1	37	39	1800	2100
240	18.4	3.4	26.8	2.0	2.2	2.2	40	41	2150	2450
300	20.5	3.4	28.9	2.0	2.2	2.3	42	44	2400	2725
400	24.0	3.4	32.4	2/2.5	2.4	2.4	47	49	2825	3450
500	27.0	3.4	35.4	2.5	2.5	2.5	51	52	3500	3900
630	30.4	3.4	38.8	2.5	2.6	2.7	55	57	4125	4600

Size	Max DC Resistance @ 20°C	Inductance		Capacitance	Conductor Short Circuit Current for 1 second	Current ratings						Voltage drop per phase	
		Trefoil	Flat			Buried Direct In the ground		In single-way ducts		In air			
						Trefoil	Flat Spaced	Trefoil ducts	Flat Touching ducts	Trefoil	Flat Touching		Flat Spaced
mm ²	Ohm/km	mH/km	mH/km	µF/km	kA	Amps	Amps	Amps	Amps	Amps	Amps	Amps	V/A.Km
25	1.20	0.488	0.790	0.21	2.360	107	111	101	103	126	128	147	1.323
35	0.868	0.472	0.765	0.23	3.304	127	131	121	123	152	155	178	0.979
50	0.641	0.455	0.745	0.25	4.720	150	154	142	145	182	185	212	0.743
70	0.443	0.428	0.713	0.29	6.608	182	187	174	177	226	230	263	0.535
95	0.320	0.416	0.697	0.31	8.968	217	221	207	210	275	279	317	0.407
120	0.253	0.401	0.678	0.34	11.328	246	249	235	239	317	321	363	0.336
150	0.206	0.390	0.663	0.37	14.160	274	274	262	265	360	361	405	0.286
185	0.164	0.378	0.647	0.40	17.464	309	305	297	298	413	411	457	0.241
240	0.125	0.363	0.627	0.45	22.656	355	344	342	342	485	478	526	0.198
300	0.100	0.351	0.611	0.49	28.320	397	378	383	382	552	539	587	0.17
400	0.0778	0.338	0.591	0.55	37.760	448	416	434	430	638	613	656	0.146
500	0.0605	0.328	0.576	0.60	47.200	494	446	482	470	724	677	718	0.127
630	0.0469	0.317	0.560	0.68	59.472	549	484	537	521	824	755	792	0.112

Laying condition: Maximum conductor temperature 90°C, Ambient temperature 30°C. Underground temperature of soil 20°C, Depth of laying - 0.8m. Ground thermal resistivity 1.5 K.m/W, thermal resistivity of earthenware ducts 1.2 K.m/W.

Note: Area of copper wire considered is 16 mm² up to 120 mm², 25 mm² from 150 mm² up to 300 mm², 35 mm² from 400 mm² up to 630 mm².



ARMoured SINGLE CORE CABLES

ALUMINIUM CONDUCTORS

IEC 60502-2
and BS 6622

U₀/U (U_m)=8.7 /15(17.5) kV

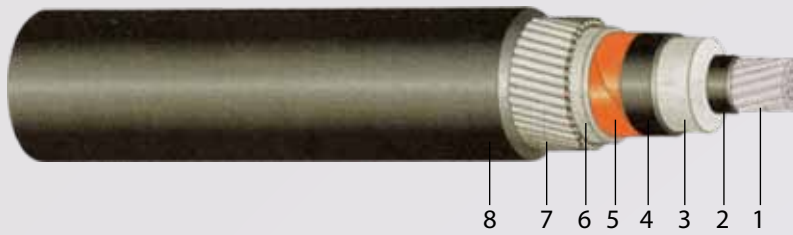

- | | |
|-------------------------------------|---------------------------------|
| 1. Conductor | 5. Insulation Screen (Metallic) |
| 2. Conductor Screen | 6. Bedding |
| 3. XLPE Insulation | 7. Aluminium Wire Armour |
| 4. Insulation Screen (Non-metallic) | 8. Outer Sheath |

Size	Diameter of Conductor (Approx.)	Nominal Insulation Thickness	Diameter Over Insulation (Approx.)	Nominal Diameter of Aluminium Wire	Nominal Outer Sheath Thickness		Overall Diameter (Approx.)		Weight of Cable (Approx.)	
				CUT/CUW	CUT	CUW	CUT	CUW	CUT	CUW
mm ²	mm	mm	mm	mm	mm	mm	mm	mm	Kg/km	Kg/km
25	6.0	4.5	16.6	1.6	1.8	1.9	28	30	925	1175
35	7.1	4.5	17.7	1.6	1.9	1.9	30	31	1050	1275
50	8.3	4.5	18.9	1.6	1.9	1.9	31	32	1100	1350
70	9.7	4.5	20.3	1.6	1.9	2.0	33	34	1225	1500
95	11.55	4.5	22.15	2.0	2.0	2.1	35	37	1475	1775
120	12.95	4.5	23.55	2.0	2.1	2.1	37	38	1625	1875
150	14.3	4.5	24.9	2.0	2.1	2.2	38	40	1775	2100
185	15.9	4.5	26.5	2.0	2.2	2.2	40	41	2025	2325
240	18.4	4.5	29.0	2.0	2.3	2.3	43	44	2300	2650
300	20.5	4.5	31.1	2.5	2.3	2.4	46	48	2575	3075
400	24.0	4.5	34.6	2.5	2.5	2.5	50	51	3225	3675
500	27.0	4.5	37.6	2.5	2.6	2.6	53	55	3700	4175
630	30.4	4.5	41.0	2.5	2.7	2.7	57	59	4375	4850

Size	Max DC Resistance @ 20°C	Inductance		Capacitance	Conductor Short Circuit Current for 1 second	Current ratings							Voltage drop per phase
		Trefoil	Flat			Buried Direct In the ground	In single-way ducts		In air				
							Trefoil	Flat Spaced	Trefoil ducts	Flat Touching ducts	Trefoil	Flat Touching	
mm ²	Ohm/km	mH/km	mH/km	µF/km	kA	Amps	Amps	Amps	Amps	Amps	Amps	Amps	V/A.Km
25	1.20	0.505	0.796	0.17	2.360	107	111	101	103	126	128	147	1.326
35	0.868	0.484	0.771	0.19	3.304	127	131	121	123	152	155	178	0.982
50	0.641	0.468	0.751	0.21	4.720	150	154	142	145	182	185	212	0.746
70	0.443	0.441	0.719	0.23	6.608	182	187	174	177	226	230	263	0.538
95	0.320	0.428	0.703	0.25	8.968	217	221	207	210	275	279	317	0.409
120	0.253	0.413	0.684	0.27	11.328	246	249	235	239	317	321	363	0.338
150	0.206	0.401	0.668	0.29	14.160	274	274	262	265	360	361	405	0.288
185	0.164	0.388	0.652	0.32	17.464	309	305	297	298	413	411	457	0.242
240	0.125	0.373	0.632	0.35	22.656	355	344	342	342	485	478	526	0.200
300	0.100	0.361	0.616	0.39	28.320	397	378	383	382	552	539	587	0.172
400	0.0778	0.346	0.596	0.43	37.760	448	416	434	430	638	613	656	0.147
500	0.0605	0.337	0.582	0.48	47.200	494	446	482	470	724	677	718	0.128
630	0.0469	0.325	0.656	0.53	59.472	549	484	537	521	824	755	792	0.113

Laying condition: Maximum conductor temperature 90°C, Ambient temperature 30°C. Underground temperature of soil 20°C, Depth of laying - 0.8m. Ground thermal resistivity 1.5 K.m/W, thermal resistivity of earthenware ducts 1.2 K.m/W.

Note: Area of copper wire considered is 16 mm² up to 120 mm², 25 mm² from 150 mm² up to 300 mm², 35 mm² from 400 mm² up to 630 mm².



ARMOURED SINGLE CORE CABLES

ALUMINIUM CONDUCTORS

IEC 60502-2
and BS 6622

$U_0/U (U_m)=12/20(24) \text{ kV}$
 $12.7/22(24) \text{ kV}$

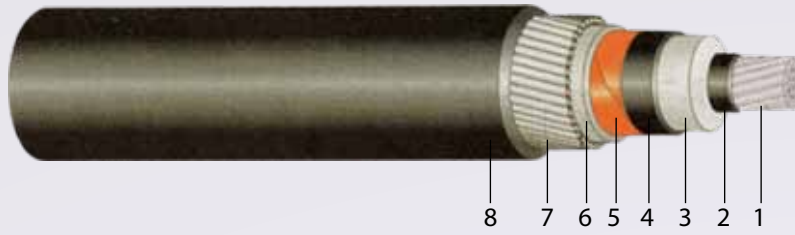

1. Conductor
2. Conductor Screen
3. XLPE Insulation
4. Insulation Screen (Non-metallic)
5. Insulation Screen (Metallic)
6. Bedding
7. Aluminium Wire Armour
8. Outer Sheath

Size	Diameter of Conductor (Approx.)	Nominal Insulation Thickness	Diameter Over Insulation (Approx.)	Nominal Diameter of Aluminium Wire	Nominal Outer Sheath Thickness		Overall Diameter (Approx.)		Weight of Cable (Approx.)	
				CUT/CUW	CUT	CUW	CUT	CUW	CUT	CUW
mm ²	mm	mm	mm	mm	mm	mm	mm	mm	Kg/km	Kg/km
25	6.0	6.0	19.6	1.6	1.9	2.0	32	33	1150	1375
35	7.1	5.5	19.7	1.6	1.9	2.0	32	33	1175	1400
50	8.3	5.5	20.9	1.6	2.0	2.0	32	35	1250	1600
70	9.7	5.5	22.3	2.0	2.0	2.1	35	37	1500	1700
95	11.55	5.5	24.15	2.0	2.1	2.1	37	39	1650	1875
120	12.95	5.5	25.55	2.0	2.1	2.2	39	40	1850	2100
150	14.3	5.5	26.9	2.0	2.2	2.2	40	42	2000	2300
185	15.9	5.5	28.5	2.0	2.2	2.3	42	44	2200	2525
240	18.4	5.5	31.0	2.0/2.5	2.3	2.4	45	48	2475	3025
300	20.5	5.5	33.1	2.5	2.4	2.5	48	50	2925	3325
400	24.0	5.5	36.6	2.5	2.5	2.6	52	54	3425	3900
500	27.0	5.5	39.6	2.5	2.6	2.7	56	57	4000	4450
630	30.4	5.5	43.0	2.5	2.8	2.8	59	61	4650	5100

Size	Max DC Resistance @ 20°C	Inductance		Capacitance	Conductor Short Circuit Current for 1 second	Current ratings							Voltage drop per phase
		Trefoil	Flat			Buried Direct In the ground	In single -way ducts		In air				
							Trefoil	Flat Spaced	Trefoil ducts	Flat Touching ducts	Trefoil	Flat Touching	
mm ²	Ohm/km	mH/km	mH/km	µF/km	kA	Amps	Amps	Amps	Amps	Amps	Amps	Amps	V/A.Km
25	1.20	0524	0.805	0.14	2.360	107	111	101	103	126	128	147	1.33
35	0.868	0.496	0.776	0.16	3.304	127	131	121	123	152	155	178	0.984
50	0.641	0.478	0.456	0.18	4.720	150	154	142	145	182	185	212	0.748
70	0.443	0.452	0.724	0.20	6.608	182	187	174	177	226	230	263	0.540
95	0.320	0.438	0.708	0.21	8.968	217	221	207	210	275	279	317	0.411
120	0.253	0.23	0.689	0.23	11.328	246	249	235	239	317	321	363	0.34
150	0.206	0.410	0.673	0.25	14.160	274	274	262	265	360	361	405	0.289
185	0.164	0.397	0.657	0.27	17.464	309	305	297	298	413	411	457	0.244
240	0.125	0.382	0.637	0.30	22.656	355	344	342	342	485	478	526	0.201
300	0.100	0.370	0.621	0.33	28.320	397	378	383	382	552	539	587	0.174
400	0.0778	0.355	0.601	0.37	37.760	448	416	434	430	638	613	656	0.149
500	0.0605	0.345	0.586	0.40	47.200	494	446	482	470	724	677	718	0.130
630	0.0469	0.333	0.569	0.45	59.472	549	484	537	521	824	755	792	0.115

Laying condition: Maximum conductor temperature 90°C, Ambient temperature 30°C. Underground temperature of soil 20°C, Depth of laying - 0.8m. Ground thermal resistivity 1.5 K.m/W, thermal resistivity of earthenware ducts 1.2 K.m/W.

Note: Area of copper wire considered is 16 mm² up to 120 mm², 25 mm² from 150 mm² up to 300 mm², 35 mm² from 400 mm² up to 630 mm².



ARMOURED SINGLE CORE CABLES

ALUMINIUM CONDUCTORS

IEC 60502-2
and BS 6622

$U_0/U (U_m)=18/30(36) \text{ kV}$
 $19/33(36) \text{ kV}$

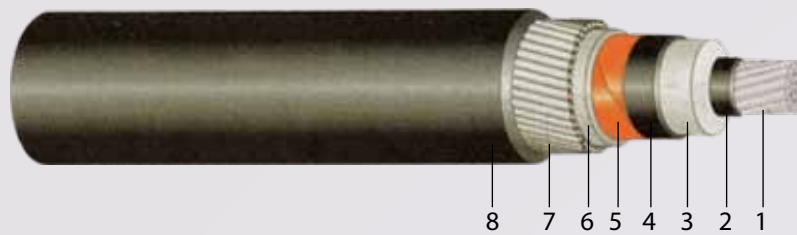

- | | |
|-------------------------------------|---------------------------------|
| 1. Conductor | 5. Insulation Screen (Metallic) |
| 2. Conductor Screen | 6. Bedding |
| 3. XLPE Insulation | 7. Aluminium Wire Armour |
| 4. Insulation Screen (Non-metallic) | 8. Outer Sheath |

Size	Diameter of Conductor (Approx.)	Nominal Insulation Thickness	Diameter Over Insulation (Approx.)	Nominal Diameter of Aluminium Wire		Nominal Outer Sheath Thickness		Overall Diameter (Approx.)		Weight of Cable (Approx)	
				CUT/CUW	CUT	CUW	CUT	CUW	CUT	CUW	
mm ²	mm	mm	mm	mm	mm	mm	mm	mm	Kg/km	Kg/km	
50	8.3	8.0	25.9	2.0	2.2	2.2	39	41	1775	2000	
70	9.7	8.0	27.3	2.0	2.2	2.3	41	42	1900	2150	
95	11.55	8.0	29.15	2.0	2.3	2.3	43	44	2125	2350	
120	12.95	8.0	30.55	2.5	2.3	2.4	44	46	2225	2500	
150	14.3	8.0	31.9	2.5	2.4	2.5	47	49	2600	2950	
185	15.9	8.0	33.5	2.5	2.5	2.5	49	50	2850	3150	
240	18.4	8.0	36.0	2.5	2.5	2.6	52	53	3125	3550	
300	20.5	8.0	38.1	2.5	2.6	2.7	54	55	3475	3875	
400	24.0	8.0	41.6	2.5	2.7	2.8	58	60	4050	4550	
500	27.0	8.0	44.6	2.5	2.8	2.9	61	63	4600	5075	
630	30.4	8.0	48.0	2.5	2.9	3.0	65	67	5275	5775	

SIZE	Max DC Resistance @ 20°C	Inductance		Capacitance	Conductor Short Circuit Current for 1 second	Current ratings							Voltage drop per phase	
		Trefoil	Flat			Buried Direct In the ground	In single -way ducts		In air					
							Trefoil	Flat Spaced	Trefoil ducts	Flat Touching ducts	Trefoil	Flat Touching		Flat Spaced
mm ²	Ohm/km	mH/km	mH/km	µF/km	kA	Amps	Amps	Amps	Amps	Amps	Amps	Amps	Amps	V/A.Km
50	0.641	0.509	0.772	0.14	4.720	150	154	142	145	182	185	212	0.754	
70	0.443	0.481	0.740	0.16	6.608	182	187	174	177	226	230	263	0.545	
95	0.320	0.467	0.723	0.17	8.968	217	221	207	210	275	279	317	0.417	
120	0.253	0.450	0.704	0.18	11.328	246	249	235	239	317	321	363	0.345	
150	0.206	0.437	0.688	0.19	14.160	274	274	262	265	360	361	405	0.294	
185	0.164	0.424	0.672	0.21	17.464	309	305	297	298	413	411	457	0.249	
240	0.125	0.407	0.652	0.23	22.656	355	344	342	342	485	478	526	0.206	
300	0.100	0.394	0.635	0.25	28.320	397	378	383	382	552	539	587	0.179	
400	0.0778	0.377	0.614	0.27	37.760	448	416	434	430	638	613	656	0.153	
500	0.0605	0.366	0.599	0.30	47.200	494	446	482	470	724	677	718	0.134	
630	0.0469	0.353	0.582	0.33	59.472	549	484	537	521	824	755	792	0.118	

Laying condition: Maximum conductor temperature 90°C, Ambient temperature 30°C. Underground temperature of soil 20°C, Depth of laying - 0.8m. Ground thermal resistivity 1.5 K.m/W, thermal resistivity of earthenware ducts 1.2 K.m/W.

Note: Area of copper wire considered is 16 mm² up to 120 mm², 25 mm² from 150 mm² up to 300 mm², 35 mm² from 400 mm² up to 630 mm².



UNARMoured THREE CORE CABLES

ALUMINIUM CONDUCTORS

IEC 60502-2
and BS 6622

$U_0/U (U_m)=3.6/6(7.2) \text{ kV}$
 $3.8/6.6(7.2) \text{ kV}$

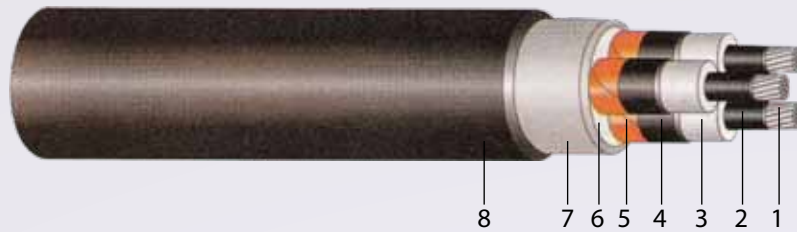

- | | |
|-------------------------------------|---------------------------------|
| 1. Conductor | 5. Insulation Screen (Metallic) |
| 2. Conductor Screen | 6. PP Filler |
| 3. XLPE Insulation | 7. Bedding |
| 4. Insulation Screen (Non-metallic) | 8. Outer Sheath |

Size	Diameter of Conductor (Approx.)	Nominal Insulation Thickness	Diameter Over Insulation (Approx.)	Nominal Outer Sheath Thickness		Overall Diameter (Approx.)		Weight of Cable (Approx)	
				CUT	CUW	CUT	CUW	CUT	CUW
mm ²	mm	mm	mm	mm	mm	mm	mm	Kg/km	Kg/km
25	6.0	2.5	12.6	2.1	2.1	39	42	1425	1600
35	7.1	2.5	13.7	2.1	2.2	41	45	1625	1825
50	8.3	2.5	14.9	2.2	2.3	44	48	1875	2100
70	9.7	2.5	16.3	2.3	2.4	45	51	2250	2450
95	11.55	2.5	18.15	2.5	2.5	47	55	2725	2900
120	12.95	2.5	19.55	2.6	2.6	55	59	3100	3300
150	14.3	2.5	20.9	2.7	2.8	58	62	3550	3800
185	15.9	2.5	22.5	2.8	2.9	62	65	4050	4325
240	18.4	2.6	25.2	3.0	3.0	68	72	4975	5225
300	20.5	2.8	27.7	3.2	3.2	75	78	6050	6275

Size	Max DC Resistance @ 20°C	Nominal Inductance	Capacitance	Conductor Short Circuit Current for 1 second	Current ratings			Voltage drop Per phase
					Buried Direct In the ground	In buried ducts	In air	
mm ²	Ohm/km	mH/km	µF/km	kA	Amps	Amps	Amps	V/A.Km
25	1.20	0.305	0.26	2.360	100	87	110	1.288
35	0.868	0.294	0.29	3.304	119	103	132	0.946
50	0.641	0.283	0.31	4.720	140	122	158	0.711
70	0.443	0.272	0.36	6.608	171	150	196	0.506
95	0.320	0.266	0.39	8.968	203	179	236	0.379
120	0.253	0.259	0.43	11.328	232	205	273	0.309
150	0.206	0.253	0.47	14.160	260	231	309	0.259
185	0.164	0.250	0.52	17.464	294	262	355	0.217
240	0.125	0.243	0.56	22.656	340	305	415	0.175
300	0.100	0.236	0.58	28.320	384	346	475	0.149

Laying condition: Maximum conductor temperature 90°C, Ambient temperature 30°C. Underground temperature of soil 20°C, Depth of laying - 0.8m.
Ground thermal resistivity 1.5 K.m/W, thermal resistivity of earthenware ducts 1.2 K.m/W.

Note: Area of copper wire considered is 16 mm² up to 120 mm², 25 mm² from 150 mm² up to 300 mm², 35 mm² from 400 mm² up to 630 mm².



UNARMoured THREE CORE CABLES

ALUMINIUM CONDUCTORS

IEC 60502-2
and BS 6622

$U_0/U (U_m)=6 /10(12) \text{ kV}$
 $6.35/11(12) \text{ kV}$



- 1. Conductor
- 2. Conductor Screen
- 3. XLPE Insulation
- 4. Insulation Screen (Non-metallic)
- 5. Insulation Screen (Metallic)
- 6. PP Filler
- 7. Bedding
- 8. Outer Sheath

Size	Diameter of Conductor (Approx.)	Nominal Insulation Thickness	Diameter Over Insulation (Approx.)	Nominal Outer Sheath Thickness		Overall Diameter (Approx.)		Weight of Cable (Approx)	
				CUT	CUW	CUT	CUW	CUT	CUW
mm ²	mm	mm	mm	mm	mm	mm	mm	Kg/km	Kg/km
25	6.0	3.4	14.4	2.2	2.2	43	46	1700	1850
35	7.1	3.4	15.5	2.3	2.3	46	49	1950	2150
50	8.3	3.4	16.7	2.4	2.4	49	52	2225	2400
70	9.7	3.4	18.1	2.5	2.5	52	55	2575	2750
95	11.55	3.4	19.95	2.6	2.7	56	60	3050	3275
120	12.95	3.4	21.35	2.7	2.8	60	63	3500	3675
150	14.3	3.4	22.7	2.8	2.9	63	66	3925	4175
185	15.9	3.4	24.3	2.9	3.0	67	70	4450	4750
240	18.4	3.4	26.8	3.1	3.2	73	76	5450	5775
300	20.5	3.4	28.9	3.3	3.3	79	81	6375	6600

Size	Max DC Resistance @ 20°C	Nominal Inductance	Capacitance	Conductor Short Circuit Current for 1 second	Current ratings			Voltage drop Per phase
					Buried Direct In the ground	In buried ducts	In air	
mm ²	Ohm/km	mH/km	µF/km	kA	Amps	Amps	Amps	V/A.Km
25	1.20	0.331	0.21	2.360	100	87	110	1.293
35	0.868	0.318	0.23	3.304	119	103	132	0.95
50	0.641	0.308	0.25	4.720	140	122	158	0.716
70	0.443	0.292	0.29	6.608	171	150	196	.0510
95	0.320	0.285	0.31	8.968	203	179	236	0.383
120	0.253	0.276	0.34	11.328	232	205	273	0.312
150	0.206	0.269	0.37	14.160	260	231	309	0.263
185	0.164	0.263	0.40	17.464	294	262	355	0.219
240	0.125	0.255	0.44	22.656	340	305	415	0.177
300	0.100	0.248	0.48	28.320	384	346	475	0.151

Laying condition: Maximum conductor temperature 90°C, Ambient temperature 30°C. Underground temperature of soil 20°C, Depth of laying - 0.8m.
Ground thermal resistivity 1.5 K.m/W, thermal resistivity of earthenware ducts 1.2 K.m/W.

Note: Area of copper wire considered is 16 mm² up to 120 mm², 25 mm² from 150 mm² up to 300 mm², 35 mm² from 400 mm² up to 630 mm².



UNARMoured THREE CORE CABLES

ALUMINIUM CONDUCTORS

IEC 60502-2
and BS 6622

$U_0/U(U_m)=8.7/15(17.5)$ kV

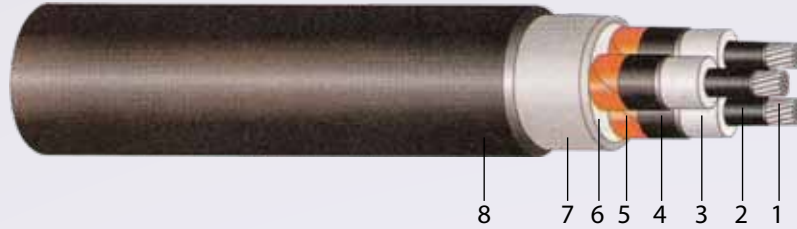

- | | |
|-------------------------------------|---------------------------------|
| 1. Conductor | 5. Insulation Screen (Metallic) |
| 2. Conductor Screen | 6. PP Filler |
| 3. XLPE Insulation | 7. Bedding |
| 4. Insulation Screen (Non-metallic) | 8. Outer Sheath |

Size	Diameter of Conductor (Approx.)	Nominal Insulation Thickness	Diameter Over Insulation (Approx.)	Nominal Outer Sheath Thickness		Overall Diameter (Approx.)		Weight of Cable (Approx)	
				CUT	CUW	CUT	CUW	CUT	CUW
mm ²	mm	mm	mm	mm	mm	mm	mm	Kg/km	Kg/km
25	6.0	4.5	16.6	2.4	2.4	49	52	1950	2025
35	7.1	4.5	17.7	2.5	2.5	52	55	2425	2525
50	8.3	4.5	18.9	2.6	2.6	55	57	2700	2800
70	9.7	4.5	20.3	2.7	2.7	58	61	3150	3250
95	11.55	4.5	22.15	2.8	2.8	63	65	3675	3875
120	12.95	4.5	23.55	2.9	2.9	66	68	4075	4200
150	14.3	4.5	24.9	3.0	3.1	69	72	4525	4725
185	15.9	4.5	26.5	3.1	3.2	73	76	5175	5350
240	18.4	4.5	29.0	3.3	3.3	79	81	6125	6275
300	20.5	4.5	31.1	3.4	3.5	84	86	6975	7150

Size	Max DC Resistance @ 20°C	Nominal Inductance	Capacitance	Conductor Short Circuit Current for 1 second	Current ratings			Voltage drop Per phase
					Buried Direct In the ground	In buried ducts	In air	
mm ²	Ohm/km	mH/km	μF/km	kA	Amps	Amps	Amps	V/A.Km
25	1.20	0.359	0.17	2.360	100	87	110	1.299
35	0.868	0.344	0.19	3.304	119	103	132	0.955
50	0.641	0.332	0.21	4.720	140	122	158	0.72
70	0.443	0.314	0.23	6.608	171	150	196	0.514
95	0.320	0.306	0.25	8.968	203	179	236	0.386
120	0.253	0.296	0.27	11.328	232	205	273	0.316
150	0.206	0.288	0.29	14.160	260	231	309	0.266
185	0.164	0.280	0.32	17.464	294	262	355	0.222
240	0.125	0.271	0.35	22.656	340	305	415	0.18
300	0.100	0.260	0.39	28.320	384	346	475	0.153

Laying condition: Maximum conductor temperature 90°C, Ambient temperature 30°C. Underground temperature of soil 20°C, Depth of laying - 0.8m. Ground thermal resistivity 1.5 K.m/W, thermal resistivity of earthenware ducts 1.2 K.m/W.

Note: Area of copper wire considered is 16 mm² up to 120 mm², 25 mm² from 150 mm² up to 300 mm², 35 mm² from 400 mm² up to 630 mm².



UNARMoured THREE CORE CABLES

ALUMINIUM CONDUCTORS

IEC 60502-2
and BS 6622

$U_0/U(U_m)=12/20(24) \text{ kV}$
 $12.7/22(24) \text{ kV}$

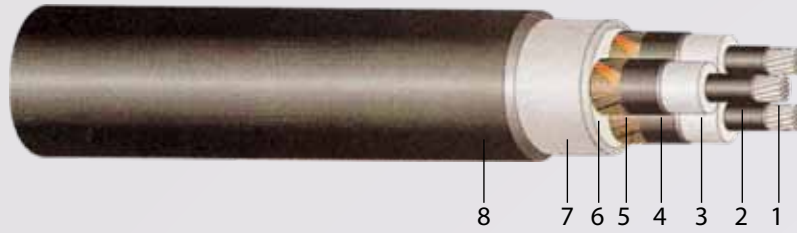

- | | |
|-------------------------------------|---------------------------------|
| 1. Conductor | 5. Insulation Screen (Metallic) |
| 2. Conductor Screen | 6. PP Filler |
| 3. XLPE Insulation | 7. Bedding |
| 4. Insulation Screen (Non-metallic) | 8. Outer Sheath |

Size	Diameter of Conductor (Approx.)	Nominal Insulation Thickness	Diameter Over Insulation (Approx.)	Nominal Outer Sheath Thickness		Overall Diameter (Approx.)		Weight of Cable (Approx.)	
				CUT	CUW	CUT	CUW	CUT	CUW
mm ²	mm	mm	mm	mm	mm	mm	mm	Kg/km	Kg/km
25	6.0	6.0	19.6	2.6	2.6	55	59	2650	2850
35	7.1	5.5	19.7	2.6	2.7	56	60	2700	2950
50	8.3	5.5	20.9	2.7	2.8	58	61	3050	3225
70	9.7	5.5	22.3	2.8	2.9	62	65	3450	3625
95	11.55	5.5	24.15	2.9	3.0	66	69	4000	4175
120	12.95	5.5	25.55	3.0	3.1	70	73	4525	4700
150	14.3	5.5	26.9	3.1	3.2	74	77	5075	5325
185	15.9	5.5	28.5	3.3	3.3	78	80	5700	5925
240	18.4	5.5	31.0	3.4	3.5	83	86	6650	6925
300	20.5	5.5	33.1	3.6	3.6	88	91	7575	7775

Size	Max DC Resistance @ 20°C	Nominal Inductance	Capacitance	Conductor Short Circuit Current for 1 second	Current ratings			Voltage drop Per phase
					Buried Direct In the ground	In buried ducts	In air	
mm ²	Ohm/km	mH/km	μF/km	kA	Amps	Amps	Amps	V/A.Km
25	1.20	0.394	0.14	2.360	100	87	110	0.305
35	0.868	0.365	0.16	3.304	119	103	132	0.959
50	0.641	0.352	0.18	4.720	140	122	158	0.724
70	0.443	0.332	0.20	6.608	171	150	196	0.517
95	0.320	0.323	0.21	8.968	203	179	236	0.389
120	0.253	0.312	0.23	11.328	232	205	273	0.319
150	0.206	0.303	0.25	14.160	260	231	309	0.269
185	0.164	0.295	0.27	17.464	294	262	355	0.225
240	0.125	0.285	0.30	22.656	340	305	415	0.183
300	0.100	0.270	0.33	28.320	384	346	475	0.155

Laying condition: Maximum conductor temperature 90°C, Ambient temperature 30°C. Underground temperature of soil 20°C, Depth of laying - 0.8m. Ground thermal resistivity 1.5 K.m/W, thermal resistivity of earthenware ducts 1.2 K.m/W.

Note: Area of copper wire considered is 16 mm² up to 120 mm², 25 mm² from 150 mm² up to 300 mm², 35 mm² from 400 mm² up to 630 mm².



UNARMoured THREE CORE CABLES

ALUMINIUM CONDUCTORS

IEC 60502-2
and BS 6622

$U_0/U (U_m)=18/30(36) \text{ kV}$
 $19/33(36) \text{ kV}$

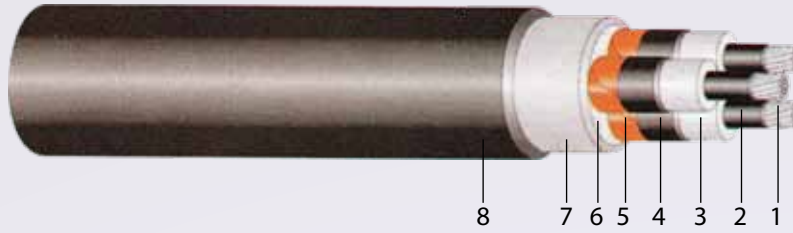

- | | |
|-------------------------------------|---------------------------------|
| 1. Conductor | 5. Insulation Screen (Metallic) |
| 2. Conductor Screen | 6. PP Filler |
| 3. XLPE Insulation | 7. Bedding |
| 4. Insulation Screen (Non-metallic) | 8. Outer Sheath |

Size	Diameter of Conductor (Approx.)	Nominal Insulation Thickness	Diameter Over Insulation (Approx.)	Nominal Outer Sheath Thickness		Overall Diameter (Approx.)		Weight of Cable (Approx)	
				CUT	CUW	CUT	CUW	CUT	CUW
mm ²	mm	mm	mm	mm	mm	mm	mm	Kg/km	Kg/km
50	8.3	8.0	25.9	3.1	3.1	72	74	4300	4425
70	9.7	8.0	27.3	3.2	3.2	75	77	4825	4950
95	11.5	8.0	29.15	3.4	3.4	79	82	5475	5600
120	12.95	8.0	30.55	3.4	3.5	82	85	5925	6100
150	14.3	8.0	31.9	3.5	3.6	85	88	6450	6625
185	15.9	8.0	33.5	3.6	3.7	89	92	7100	7275
240	18.4	8.0	36.0	3.8	3.9	95	98	8275	8475
300	20.5	8.0	38.1	4.0	4.0	100	103	9275	9425

Size	Max DC Resistance @ 20°C	Nominal Inductance	Capacitance	Conductor Short Circuit Current for 1 second	Current ratings			Voltage drop Per phase
					Buried Direct In the ground	In buried ducts	In air	
mm ²	Ohm/km	mH/km	μF/km	kA	Amps	Amps	Amps	V/A.Km
50	0.641	0.404	0.14	4.720	140	122	158	0.734
70	0.443	0.380	0.16	6.608	171	150	196	0.526
95	0.320	0.369	0.17	8.968	203	179	236	0.398
120	0.253	0.355	0.18	11.328	232	205	273	0.327
150	0.206	0.345	0.19	14.160	260	231	309	0.277
185	0.164	0.334	0.21	17.464	294	262	355	0.232
240	0.125	0.321	0.23	22.656	340	305	415	0.19
300	0.100	0.308	0.25	28.320	384	346	475	0.162

Laying condition: Maximum conductor temperature 90°C, Ambient temperature 30°C. Underground temperature of soil 20°C, Depth of laying - 0.8m. Ground thermal resistivity 1.5 K.m/W, thermal resistivity of earthenware ducts 1.2 K.m/W.

Note: Area of copper wire considered is 16 mm² up to 120 mm², 25 mm² from 150 mm² up to 300 mm², 35 mm² from 400 mm² up to 630 mm².



ARMOURED THREE CORE CABLES

ALUMINIUM CONDUCTORS

IEC 60502-2
and BS 6622

$U_0/U (U_m)=3.6/6(7.2) \text{ kV}$
 $3.8/6.6(7.2) \text{ kV}$

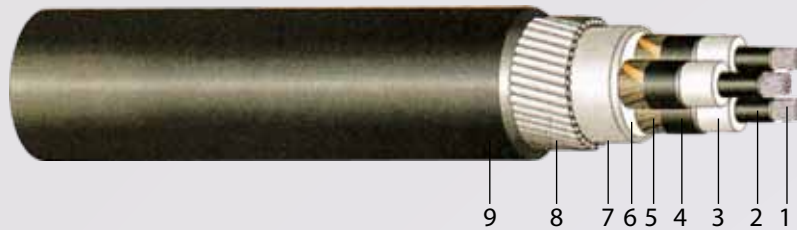

- | | |
|-------------------------------------|----------------------|
| 1. Conductor | 6. PP Filler |
| 2. Conductor Screen | 7. Bedding |
| 3. XLPE Insulation | 8. Steel Wire Armour |
| 4. Insulation Screen (Non-Metallic) | 9. Outer Sheath |
| 5. Insulation Screen (Metallic) | |

Size	Diameter of Conductor (Approx.)	Nominal Insulation Thickness	Diameter Over Insulation (Approx.)	Number & Nominal Thickness of steel Wire		Nominal Outer Sheath Thickness		Overall Diameter (Approx.)		Weight of Cable (Approx)	
				CUT / CUT	CUT	CUW	CUT	CUW	CUT	CUW	
Mm ²	mm	mm	mm	mm	mm	mm	mm	mm	Kg/km	Kg/km	
25	6.0	2.5	12.6	2.0	2.3	2.3	42	45	2850	3025	
35	7.1	2.5	13.7	2.0	2.3	2.4	45	50	3150	3900	
50	8.3	2.5	14.9	2.5	2.5	2.5	49	52	3950	4275	
70	9.7	2.5	16.3	2.5	2.6	2.6	53	55	4475	4750	
95	11.55	2.5	18.15	2.5	2.7	2.8	57	60	5150	5450	
120	12.95	2.5	19.55	2.5	2.8	2.9	60	64	5475	6025	
150	14.3	2.5	20.9	2.5	2.9	3.0	63	67	6200	6675	
185	15.9	2.5	22.5	2.5	3.1	3.1	67	70	6975	7350	
240	18.4	2.6	25.2	2.5/3.15	3.3	3.3	74	78	8150	9500	
300	20.5	2.8	27.7	3.15	3.5	3.5	82	85	10525	10875	

Size	Max DC Resistance @ 20°C	Nominal Inductance	Capacitance	Conductor Short Circuit Current for 1 second	Current ratings			Voltage drop Per phase
					Buried Direct In the ground	In buried ducts	In air	
mm ²	Ohm/km	mH/km	μF/km	kA	Amps	Amps	Amps	V/A.Km
25	1.20	0.363	0.26	2.360	100	87	111	1.299
35	0.868	0.344	0.29	3.304	119	104	133	0.955
50	0.641	0.333	0.31	4.720	140	123	159	0.721
70	0.443	0.322	0.36	6.608	171	150	196	0.515
95	0.320	0.316	0.39	8.968	204	180	238	0.388
120	0.253	0.309	0.43	11.328	232	206	274	0.318
150	0.206	0.303	0.47	14.160	259	231	309	0.269
185	0.164	0.300	0.52	17.464	293	262	354	0.226
240	0.125	0.293	0.56	22.656	338	304	415	0.185
300	0.100	0.286	0.58	28.320	380	343	472	0.158

Laying condition: Maximum conductor temperature 90°C, Ambient temperature 30°C. Underground temperature of soil 20°C, Depth of laying - 0.8m. Ground thermal resistivity 1.5 K.m/W, thermal resistivity of earthenware ducts 1.2 K.m/W.

Note: Area of copper wire considered is 16 mm² up to 120 mm², 25 mm² from 150 mm² up to 300 mm², 35 mm² from 400 mm² up to 630 mm².



ARMOURED THREE CORE CABLES

ALUMINIUM CONDUCTORS

IEC 60502-2
and BS 6622

$U_0/U (U_m)=6 /10(12) \text{ kV}$
 $6.35/11(12) \text{ kV}$

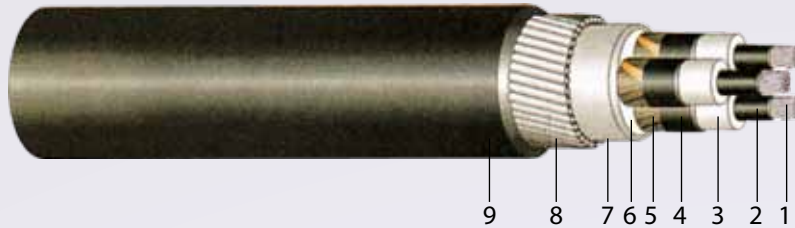

- | | |
|-------------------------------------|----------------------|
| 1. Conductor | 6. PP Filler |
| 2. Conductor Screen | 7. Bedding |
| 3. XLPE Insulation | 8. Steel Wire Armour |
| 4. Insulation Screen (Non-Metallic) | 9. Outer Sheath |
| 5. Insulation Screen (Metallic) | |

Size	Diameter of Conductor (Approx.)	Nominal Insulation Thickness	Diameter Over Insulation (Approx.)	Number & Nominal Thickness of steel Wire	Nominal Outer Sheath Thickness		Overall Diameter (Approx.)		Weight of Cable (Approx)	
				CUT / CUT	CUT	CUW	CUT	CUW	CUT	CUW
mm ²	mm	mm	mm	mm	mm	mm	mm	mm	Kg/km	Kg/km
25	6.0	3.4	14.5	2.5	2.4	2.5	48	51	3700	4050
35	7.1	3.4	15.5	2.5	2.5	2.6	50	54	4050	4375
50	8.3	3.4	16.7	2.5	2.6	2.7	54	57	4475	4775
70	9.7	3.4	18.1	2.5	2.7	2.8	57	60	4950	5325
95	11.55	3.4	19.95	2.5	2.9	2.9	61	64	5700	6025
120	12.95	3.4	21.35	2.5	3.0	3.0	65	68	6300	6575
150	14.3	3.4	22.7	2.5	3.1	3.2	68	71	6850	7275
185	15.9	3.4	24.3	2.5	3.2	3.3	72	75	7600	8025
240	18.4	3.4	26.8	3.15	3.4	3.5	80	83	9875	10325
300	20.5	3.4	28.9	3.15	3.6	3.6	85	88	11025	11450

Size	Max DC Resistance @ 20°C	Nominal Inductance	Capacitance	Conductor Short Circuit Current for 1 second	Current ratings			Voltage drop Per phase
					Buried Direct In the ground	In buried ducts	In air	
mm ²	Ohm/km	mH/km	µF/km	kA	Amps	Amps	Amps	V/A.Km
25	1.20	0.387	0.21	2.360	100	87	111	1.304
35	0.868	0.368	0.23	3.304	119	104	133	0.960
50	0.641	0.355	0.25	4.720	140	123	159	0.725
70	0.443	0.342	0.29	6.608	171	150	196	0.519
95	0.320	0.355	0.31	8.968	204	180	238	0.392
120	0.253	0.326	0.34	11.328	232	206	274	0.321
150	0.206	0.319	0.37	14.160	259	231	309	0.272
185	0.164	0.313	0.40	17.464	293	262	354	0.228
240	0.125	0.303	0.44	22.656	338	304	415	0.187
300	0.100	0.297	0.48	28.320	380	343	472	0.160

Laying condition: Maximum conductor temperature 90°C, Ambient temperature 30°C. Underground temperature of soil 20°C, Depth of laying - 0.8m. Ground thermal resistivity 1.5 K.m/W, thermal resistivity of earthenware ducts 1.2 K.m/W.

Note: Area of copper wire considered is 16 mm² up to 120 mm², 25 mm² from 150 mm² up to 300 mm², 35 mm² from 400 mm² up to 630 mm².



ARMoured THREE CORE CABLES

ALUMINIUM CONDUCTORS

IEC 60502-2
and BS 6622

$U_0/U (U_m)=8.7/15(17.5) \text{ kV}$



- | | |
|-------------------------------------|----------------------|
| 1. Conductor | 6. PP Filler |
| 2. Conductor Screen | 7. Bedding |
| 3. XLPE Insulation | 8. Steel Wire Armour |
| 4. Insulation Screen (Non-Metallic) | 9. Outer Sheath |
| 5. Insulation Screen (Metallic) | |

Size	Diameter of Conductor (Approx.)	Nominal Insulation Thickness	Diameter Over Insulation (Approx.)	Number & Nominal Thickness of steel Wire	Nominal Outer Sheath Thickness		Overall Diameter (Approx.)		Weight of Cable (Approx)	
				CUT / CUT	CUT	CUW	CUT	CUW	CUT	CUW
mm ²	mm	mm	mm	mm	mm	mm	mm	mm	Kg/km	Kg/km
25	6.0	4.5	16.6	2.5	2.6	2.6	53	56	4350	4625
35	7.1	4.5	17.7	2.5	2.7	2.7	56	59	4700	5000
50	8.3	4.5	18.9	2.5	2.8	2.8	59	62	5175	5450
70	9.7	4.5	20.3	2.5	2.9	2.9	62	65	5675	6050
95	11.55	4.5	22.15	2.5	3.0	3.1	66	70	6425	6725
120	12.95	4.5	23.55	2.5	3.2	3.2	70	73	7000	7350
150	14.3	4.5	24.9	2.5	3.3	3.4	73	78	7600	8925
185	15.9	4.5	26.5	3.15	3.4	3.5	79	82	9450	9900
240	18.4	4.5	29.0	3.15	3.6	3.7	85	88	10775	11200
300	20.5	4.5	31.1	3.15	3.8	3.8	90	93	12000	12400

Size	Max DC Resistance @ 20°C	Nominal Inductance	Capacitance	Conductor Short Circuit Current for 1 second	Current ratings			Voltage drop Per phase
					Buried Direct In the ground	In buried ducts	In air	
mm ²	Ohm/km	mH/km	µF/km	kA	Amps	Amps	Amps	V/A.Km
25	1.20	0.413	0.17	2.360	100	87	111	1.309
35	0.868	0.394	0.19	3.304	119	104	133	0.965
50	0.641	0.382	0.21	4.720	140	123	159	0.73
70	0.443	0.364	0.23	6.608	171	150	196	0.523
95	0.320	0.356	0.25	8.968	204	180	238	0.396
120	0.253	.0346	0.27	11.328	232	206	274	0.325
150	0.206	0.338	0.29	14.160	259	231	309	0.276
185	0.164	0.330	0.32	17.464	293	262	354	0.232
240	0.125	0.321	0.35	22.656	338	304	415	0.19
300	0.100	0.312	0.39	28.320	380	343	472	0.163

Laying condition: Maximum conductor temperature 90°C, Ambient temperature 30°C. Underground temperature of soil 20°C, Depth of laying - 0.8m. Ground thermal resistivity 1.5 K.m/W, thermal resistivity of earthenware ducts 1.2 K.m/W.

Note: Area of copper wire considered is 16 mm² up to 120 mm², 25 mm² from 150 mm² up to 300 mm², 35 mm² from 400 mm² up to 630 mm².



ARMOURED THREE CORE CABLES

ALUMINIUM CONDUCTORS

IEC 60502-2
and BS 6622

$U_0/U (U_m)=12/20(24) \text{ kV}$
 $12.7/22(24) \text{ kV}$



- 1. Conductor
- 2. Conductor Screen
- 3. XLPE Insulation
- 4. Insulation Screen (Non-Metallic)
- 5. Insulation Screen (Metallic)
- 6. PP Filler
- 7. Bedding
- 8. Steel Wire Armour
- 9. Outer Sheath

Size	Diameter of Conductor (Approx.)	Nominal Insulation Thickness	Diameter Over Insulation (Approx.)	Number & Nominal Thickness of steel Wire	Nominal Outer Sheath Thickness		Overall Diameter (Approx.)		Weight of Cable (Approx.)	
				CUT / CUT	CUT	CUW	CUT	CUW	CUT	CUW
mm ²	mm	mm	mm	mm	mm	mm	mm	mm	Kg/km	Kg/km
25	6.0	6.0	19.6	2.5	2.8	2.9	60	63	5225	5575
35	7.1	5.5	19.7	2.5	2.8	2.9	60	64	5325	5650
50	8.3	5.5	20.9	2.5	2.9	3.0	64	67	5825	6100
70	9.7	5.5	22.3	2.5	3.1	3.1	67	70	6350	6675
95	11.55	5.5	24.15	2.5	3.2	3.3	71	74	7150	7400
120	12.95	5.5	25.55	3.15	3.4	3.4	77	80	8700	9100
150	14.3	5.5	26.9	3.15	3.5	3.5	80	83	9400	9875
185	15.9	5.5	28.5	3.15	3.6	3.6	84	87	10300	10700
240	18.4	5.5	31.0	3.15	3.8	3.8	90	93	11625	12075
300	20.5	5.5	33.1	3.15	3.9	4.0	95	98	12825	13325

Size	Max DC Resistance @ 20°C	Nominal Inductance	Capacitance	Conductor Short Circuit Current for 1 second	Current ratings			Voltage drop Per phase
					Buried Direct In the ground	In buried ducts	In air	
mm ²	Ohm/km	mH/km	µF/km	kA	Amps	Amps	Amps	V/A.Km
25	1.20	0.444	0.14	2.360	100	87	111	1.314
35	0.868	0.415	0.16	3.304	119	104	133	0.968
50	0.641	0.399	0.18	4.720	140	123	159	0.733
70	0.443	0.382	0.20	6.608	171	150	196	0.527
95	0.320	0.373	0.21	8.968	204	180	238	0.399
120	0.253	0.362	0.23	11.328	232	206	274	0.328
150	0.206	0.353	0.25	14.160	259	231	309	0.279
185	0.164	0.345	0.27	17.464	293	262	354	0.234
240	0.125	0.335	0.30	22.656	338	304	415	0.192
300	0.100	0.320	0.33	28.320	380	343	472	0.165

LLaying condition: Maximum conductor temperature 90°C, Ambient temperature 30°C. Underground temperature of soil 20°C, Depth of laying - 0.8m. Ground thermal resistivity 1.5 K.m/W, thermal resistivity of earthenware ducts 1.2 K.m/W.

Note: Area of copper wire considered is 16 mm² up to 120 mm², 25 mm² from 150 mm² up to 300 mm², 35 mm² from 400 mm² up to 630 mm².



ARMOURED THREE CORE CABLES

ALUMINIUM CONDUCTORS

IEC 60502-2
and BS 6622

$U_o/U (U_m)=18/30(36) \text{ kV}$
 $19/33(36) \text{ kV}$



- | | |
|-------------------------------------|----------------------|
| 1. Conductor | 6. PP Filler |
| 2. Conductor Screen | 7. Bedding |
| 3. XLPE Insulation | 8. Steel wire Armour |
| 4. Insulation Screen (Non-Metallic) | 9. Outer Sheath |
| 5. Insulation Screen (Metallic) | |

Size	Diameter of Conductor (Approx.)	Nominal Insulation Thickness	Diameter Over Insulation (Approx.)	Number & Nominal Thickness of steel Wire	Nominal Outer Sheath Thickness		Overall Diameter (Approx.)		Weight of Cable (Approx.)	
				CUT / CUT	CUT	CUW	CUT	CUW	CUT	CUW
mm ²	mm	mm	mm	mm	mm	mm	mm	mm	Kg/km	Kg/km
50	8.3	8.0	25.9	3.15	3.4	3.5	78	81	8550	8900
70	9.7	8.0	27.3	3.15	3.5	3.6	81	84	9225	9600
95	11.5	8.0	29.15	3.15	3.6	3.7	85	80	10150	10450
120	12.95	8.0	30.55	3.15	3.8	3.8	89	92	10900	11200
150	14.3	8.0	31.9	3.15	3.9	3.9	92	95	11550	12050
185	15.3	8.0	33.5	3.15	4.0	4.0	96	99	12500	12900
240	18.4	8.0	36.0	3.15	4.2	4.2	102	105	13925	14400
300	20.5	8.0	38.1	3.15	4.3	4.4	107	110	15350	15725

Size	Max DC Resistance @ 20°C	Nominal Inductance	Capacitance	Conductor Short Circuit Current for 1 second	Current ratings			Voltage drop Per phase
					Buried Direct In the ground	In buried ducts	In air	
mm ²	Ohm/km	mH/km	μF/km	kA	Amps	Amps	Amps	V/A.Km
50	0.641	0.454	0.14	4.720	140	123	159	0.743
70	0.443	0.430	0.16	6.608	171	150	196	0.536
95	0.320	0.419	0.17	8.968	204	180	238	0.408
120	0.253	0.405	0.18	11.328	232	206	274	0.336
150	0.206	0.395	0.19	14.160	259	231	309	0.286
185	0.164	0.384	0.21	17.464	293	262	354	0.242
240	0.125	0.371	0.23	22.656	338	304	415	0.20
300	0.100	0.358	0.25	28.320	380	343	472	0.171

Laying condition: Maximum conductor temperature 90°C, Ambient temperature 30°C. Underground temperature of soil 20°C, Depth of laying - 0.8m. Ground thermal resistivity 1.5 K.m/W, thermal resistivity of earthenware ducts 1.2 K.m/W.

Note: Area of copper wire considered is 16 mm² up to 120 mm², 25 mm² from 150 mm² up to 300 mm², 35 mm² from 400 mm² up to 630 mm².



ARMoured THREE CORE CABLES

ALUMINIUM CONDUCTORS

IEC 60502-2
and BS 6622

$U_0/U (U_m)=3.6/6(7.2) \text{ kV}$
 $3.8/6.6(7.2) \text{ kV}$



- | | | |
|---------------------|-------------------------------------|----------------------|
| 1. Conductor | 4. Insulation Screen (Non-metallic) | 7. Bedding |
| 2. Conductor Screen | 5. Insulation Screen (Metallic) | 8. Steel Tape Armour |
| 3. XLPE Insulation | 6. PP Filler | 9. Outer Sheath |

Size	Diameter of Conductor (Approx.)	Nominal Insulation Thickness	Diameter Over Insulation (Approx.)	Number & Nominal Thickness of steel Tape	Nominal Outer Sheath Thickness		Overall Diameter (Approx.)		Weight of Cable (Approx.)	
					CUT	CUW	CUT	CUW	CUT	CUW
mm ²	mm	mm	mm		mm	mm	mm	mm	Kg/km	Kg/km
25	6.0	2.5	12.6	2x0.5	2.2	2.2	41	44	2000	2250
35	7.1	2.5	13.7	2x0.5	2.3	2.3	43	46	2300	2575
50	8.3	2.5	14.9	2x0.5	2.4	2.4	46	50	2625	2825
70	9.7	2.5	16.3	2x0.5	2.5	2.5	50	53	3025	3275
95	11.55	2.5	18.15	2x0.5	2.6	2.6	54	57	3550	3750
120	12.95	2.5	19.55	2x0.5	2.7	2.8	57	61	4000	4225
150	14.3	2.5	20.9	2x0.5	2.8	2.9	60	64	4450	4800
185	15.9	2.5	22.5	2x0.5	2.9	3.0	64	67	5075	5375
240	18.4	2.6	25.2	2x0.5	3.1	3.2	71	74	6100	6450
300	20.5	2.8	27.7	2x0.5	3.3	3.4	78	81	7275	7575

Size	Max DC Resistance @ 20°C	Nominal Inductance	Capacitance	Conductor Short Circuit Current for 1 second	Current ratings			Voltage drop Per phase
					Buried Direct In the ground	In buried ducts	In air	
mm ²	Ohm/km	mH/km	μF/km	kA	Amps	Amps	Amps	V/A.Km
25	1.20	0.363	0.26	2.360	100	87	111	1.299
35	0.868	0.344	0.29	3.304	119	104	133	0.955
50	0.641	0.333	0.32	4.720	140	123	159	0.721
70	0.443	0.322	0.36	6.608	171	150	196	0.515
95	0.320	0.316	0.39	8.968	204	180	238	0.388
120	0.253	0.309	0.43	11.328	232	206	274	0.318
150	0.206	0.303	0.47	14.160	259	231	309	0.269
185	0.164	0.300	0.52	17.464	293	262	354	0.226
240	0.125	0.293	0.56	22.656	338	304	415	0.185
300	0.100	0.286	0.58	28.320	380	343	472	0.158

Laying condition: Maximum conductor temperature 90°C, Ambient temperature 30°C. Underground temperature of soil 20°C, Depth of laying - 0.8m. Ground thermal resistivity 1.5 K.m/W, thermal resistivity of earthenware ducts 1.2 K.m/W.

Note: Area of copper wire considered is 16 mm² up to 120 mm², 25 mm² from 150 mm² up to 300 mm², 35 mm² from 400 mm² up to 630 mm².



ARMoured THREE CORE CABLES

ALUMINIUM CONDUCTORS

IEC 60502-2

and BS 6622

$U_0/U (U_m) = 6 / 10(12) \text{ kV}$

6.35/11(12) kV



- | | | |
|---------------------|-------------------------------------|----------------------|
| 1. Conductor | 4. Insulation Screen (Non-metallic) | 7. Bedding |
| 2. Conductor Screen | 5. Insulation Screen (Metallic) | 8. Steel Tape Armour |
| 3. XLPE Insulation | 6. PP Filler | 9. Outer Sheath |

Size	Diameter of Conductor (Approx.)	Nominal Insulation Thickness	Diameter Over Insulation (Approx.)	Number & Nominal Thickness of steel Tape	Nominal Outer Sheath Thickness		Overall Diameter (Approx.)		Weight of Cable (Approx)	
					CUT	CUW	CUT	CUW	CUT	CUW
Mm ²	mm	mm	mm		mm	mm	mm	mm	Kg/km	Kg/km
25	6.0	3.4	14.4	2x0.5	2.3	2.4	45	48	2400	2625
35	7.1	3.4	15.5	2x0.5	2.4	2.5	47	51	2675	2900
50	8.3	3.4	16.7	2x0.5	2.5	2.6	51	54	3000	3225
70	9.7	3.4	18.1	2x0.5	2.6	2.7	54	57	3400	3650
95	11.55	3.4	19.95	2x0.5	2.7	2.8	58	61	3975	4200
120	12.95	3.4	21.35	2x0.5	2.9	2.9	62	65	4475	4675
150	14.3	3.4	22.7	2x0.5	3.0	3.0	65	68	4950	5275
185	15.9	3.4	24.3	2x0.5	3.1	3.1	69	72	5600	5900
240	18.4	3.4	26.8	2x0.5	3.3	3.3	76	79	6750	7000
300	20.5	3.4	28.9	2x0.5	3.4	3.5	81	84	7675	8000

Size	Max DC Resistance @ 20°C	Nominal Inductance	Capacitance	Conductor Short Circuit Current for 1 second	Current ratings			Voltage drop Per phase
					Buried Direct In the ground	In buried ducts	In air	
mm ²	Ohm/km	mH/km	μF/km	kA	Amps	Amps	Amps	V/A.Km
25	1.20	0.387	0.21	2.360	100	87	111	1.304
35	0.868	0.368	0.23	3.304	119	104	133	0.960
50	0.641	0.355	0.25	4.720	140	123	159	0.725
70	0.443	0.342	0.29	6.608	171	150	196	0.519
95	0.320	0.355	0.31	8.968	204	180	238	0.392
120	0.253	0.326	0.34	11.328	232	206	274	0.321
150	0.206	0.319	0.37	14.160	259	231	309	0.272
185	0.164	0.313	0.40	17.464	293	262	354	0.228
240	0.125	0.303	0.44	22.656	338	304	415	0.187
300	0.100	0.297	0.48	28.320	380	343	472	0.160

Laying condition: Maximum conductor temperature 90°C, Ambient temperature 30°C. Underground temperature of soil 20°C, Depth of laying - 0.8m. Ground thermal resistivity 1.5 K.m/W, thermal resistivity of earthenware ducts 1.2 K.m/W.

Note: Area of copper wire considered is 16 mm² up to 120 mm², 25 mm² from 150 mm² up to 300 mm², 35 mm² from 400 mm² up to 630 mm².



ARMOURED THREE CORE CABLES

ALUMINIUM CONDUCTORS

IEC 60502-2
and BS 6622

$U_0/U(U_m)=8.7/15(17.5)$ kV



- | | | |
|---------------------|-------------------------------------|----------------------|
| 1. Conductor | 4. Insulation Screen (Non-metallic) | 7. Bedding |
| 2. Conductor Screen | 5. Insulation Screen (Metallic) | 8. Steel Tape Armour |
| 3. XLPE Insulation | 6. PP Filler | 9. Outer Sheath |

Size	Diameter of Conductor (Approx.)	Nominal Insulation Thickness	Diameter Over Insulation (Approx.)	Number & Nominal Thickness of steel Tape	Nominal Outer Sheath Thickness		Overall Diameter (Approx.)		Weight of Cable (Approx)	
					CUT	CUW	CUT	CUW	CUT	CUW
mm ²	mm	mm	mm		mm	mm	mm	mm	Kg/km	Kg/km
25	6.0	4.5	16.6	2x0.5	2.5	2.5	50	54	2875	3075
35	7.1	4.5	17.7	2x0.5	2.6	2.6	53	56	3150	3400
50	8.3	4.5	18.9	2x0.5	2.7	2.7	56	59	3500	3750
70	9.7	4.5	20.3	2x0.5	2.8	2.8	59	63	3950	4175
95	11.55	4.5	22.15	2x0.5	2.9	3.0	63	67	4550	4775
120	12.95	4.5	23.55	2x0.5	3.0	3.1	67	70	5050	5275
150	14.3	4.5	24.9	2x0.5	3.1	3.2	70	74	5550	5850
185	15.9	4.5	26.5	2x0.5	3.3	3.3	75	78	6375	6650
240	18.4	4.5	29.0	2x0.5	3.4	3.5	81	84	7425	7725
300	20.5	4.5	31.1	2x0.8	3.6	3.7	88	90	9225	9575

Size	Max DC Resistance @ 20°C	Nominal Inductance	Capacitance	Conductor Short Circuit Current for 1 second	Current ratings			Voltage drop Per phase
					Buried Direct In the ground	In buried ducts	In air	
mm ²	Ohm/km	mH/km	µF/km	kA	Amps	Amps	Amps	V/A.Km
25	1.20	0.413	0.17	2.360	100	87	111	1.309
35	0.868	0.394	0.19	3.304	119	104	133	0.965
50	0.641	0.382	0.21	4.720	140	123	159	0.73
70	0.443	0.364	0.23	6.608	171	150	196	0.523
95	0.320	0.356	0.25	8.968	204	180	238	0.396
120	0.253	.0346	0.27	11.328	232	206	274	0.325
150	0.206	0.338	0.29	14.160	259	231	309	0.276
185	0.164	0.330	0.32	17.464	293	262	354	0.232
240	0.125	0.321	0.35	22.656	338	304	415	0.19
300	0.100	0.312	0.39	28.320	380	343	472	0.163

Laying condition: Maximum conductor temperature 90°C, Ambient temperature 30°C. Underground temperature of soil 20°C, Depth of laying - 0.8m. Ground thermal resistivity 1.5 K.m/W, thermal resistivity of earthenware ducts 1.2 K.m/W.

Note: Area of copper wire considered is 16 mm² up to 120 mm², 25 mm² from 150 mm² up to 300 mm², 35 mm² from 400 mm² up to 630 mm².



ARMOURED THREE CORE CABLES

ALUMINIUM CONDUCTORS

IEC 60502-2
and BS 6622

$U_0/U (U_m)=12/20(24) \text{ kV}$
 $12.7/22(24) \text{ kV}$



- | | | |
|---------------------|-------------------------------------|----------------------|
| 1. Conductor | 4. Insulation Screen (Non-metallic) | 7. Bedding |
| 2. Conductor Screen | 5. Insulation Screen (Metallic) | 8. Steel Tape Armour |
| 3. XLPE Insulation | 6. PP Filler | 9. Outer Sheath |

Size	Diameter of Conductor (Approx.)	Nominal Insulation Thickness	Diameter Over Insulation (Approx.)	Number & Nominal Thickness of steel Tape	Nominal Outer Sheath Thickness		Overall Diameter (Approx.)		Weight of Cable (Approx)	
					CUT	CUW	CUT	CUW	CUT	CUW
mm ²	mm	mm	mm		mm	mm	mm	mm	Kg/km	Kg/km
25	6.0	6.0	19.6	2x0.5	2.7	2.8	57	61	350	3750
35	7.1	5.5	19.7	2x0.5	2.7	2.8	58	61	3625	3850
50	8.3	5.5	20.9	2x0.5	2.8	2.9	61	63	4000	4225
70	9.7	5.5	22.3	2x0.5	2.9	3.0	64	67	4475	4675
95	11.55	5.5	24.15	2x0.5	3.1	3.1	68	72	5125	5325
120	12.95	5.5	25.55	2x0.5	3.2	3.2	73	76	5775	5950
150	14.3	5.5	26.9	2x0.5	3.3	3.4	76	79	6300	6600
185	15.9	5.5	28.5	2x0.5	3.4	3.5	80	83	7000	7300
240	18.4	5.5	31.0	2x0.5	3.6	3.7	87	90	8925	9250
300	20.5	5.5	33.1	2x0.5	3.8	3.9	92	95	9950	10350

Size	Max DC Resistance @ 20°C	Nominal Inductance	Capacitance	Conductor Short Circuit Current for 1 second	Current ratings			Voltage drop Per phase
					Buried Direct In the ground	In buried ducts	In air	
mm ²	Ohm/km	mH/km	μF/km	kA	Amps	Amps	Amps	V/A.Km
25	1.20	0.444	0.14	2.360	100	87	111	1.314
35	0.868	0.415	0.16	3.304	119	104	133	0.968
50	0.641	0.399	0.18	4.720	140	123	159	0.733
70	0.443	0.382	0.20	6.608	171	150	196	0.527
95	0.320	0.373	0.21	8.968	204	180	238	0.399
120	0.253	0.362	0.23	11.328	232	206	274	0.328
150	0.206	0.353	0.25	14.160	259	231	309	0.279
185	0.164	0.345	0.27	17.464	293	262	354	0.234
240	0.125	0.335	0.30	22.656	338	304	415	0.192
300	0.100	0.320	0.33	28.320	380	343	472	0.165

Laying condition: Maximum conductor temperature 90°C, Ambient temperature 30°C. Underground temperature of soil 20°C, Depth of laying - 0.8m.
Ground thermal resistivity 1.5 K.m/W, thermal resistivity of earthenware ducts 1.2 K.m/W.

Note: Area of copper wire considered is 16 mm² up to 120 mm², 25 mm² from 150 mm² up to 300 mm², 35 mm² from 400 mm² up to 630 mm².



ARMOURED THREE CORE CABLES

ALUMINIUM CONDUCTORS

IEC 60502-2
and BS 6622

$U_0/U (U_m)=18/30(36) \text{ kV}$
 $19/33(36) \text{ kV}$

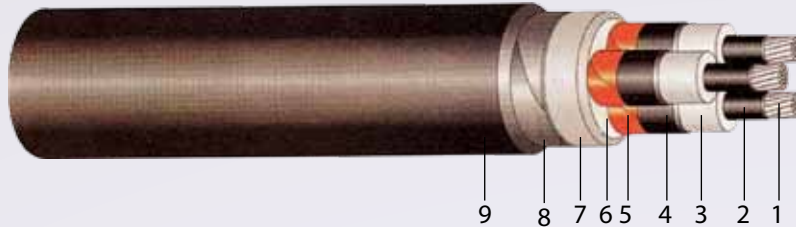

1. Conductor
2. Conductor Screen
3. XLPE Insulation

4. Insulation Screen (Non-metallic)
5. Insulation Screen (Metallic)
6. PP Filler

7. Bedding
8. Steel Tape Armour
9. Outer Sheath

Size	Diameter of Conductor (Approx.)	Nominal Insulation Thickness	Diameter Over Insulation (Approx.)	Number & Nominal Thickness of Aluminium Tape	Nominal Outer Sheath Thickness		Overall Diameter (Approx.)		Weight of Cable (Approx)	
					CUT	CUW	CUT	CUW	CUT	CUW
mm ²	mm	mm	mm		mm	mm	mm	mm	Kg/km	Kg/km
50	8.3	8.0	25.9	2x0.5	3.2	3.3	74	77	5500	5725
70	9.7	8.0	27.3	2x0.5	3.3	3.4	77	80	6050	6275
95	11.55	8.0	29.15	2x0.5	3.5	3.5	82	84	6775	6950
120	12.95	8.0	30.55	2x0.8	3.6	3.7	86	89	8150	8400
150	14.3	8.0	31.9	2x0.8	3.7	3.8	89	92	8775	9075
185	15.9	8.0	33.5	2x0.8	3.9	3.9	93	96	9600	9825
240	18.4	8.0	36.0	2x0.8	4.0	4.1	100	102	10900	11125
300	20.5	8.0	38.1	2x0.8	4.2	4.2	104	107	12050	12275

Size	Max DC Resistance @ 20°C	Nominal Inductance	Capacitance	Conductor Short Circuit Current for 1 second	Current ratings			Voltage drop Per phase
					Buried Direct In the ground	In buried ducts	In air	
mm ²	Ohm/km	mH/km	μF/km	kA	Amps	Amps	Amps	V/A.Km
50	0.641	0.454	0.14	4.720	140	123	159	0.743
70	0.443	0.430	0.16	6.608	171	150	196	0.536
95	0.320	0.419	0.17	8.968	204	180	238	0.408
120	0.253	0.405	0.18	11.328	232	206	274	0.336
150	0.206	0.395	0.19	14.160	259	231	309	0.286
185	0.164	0.384	0.21	17.464	293	262	304	0.242
240	0.125	0.371	0.23	22.656	338	304	415	0.20
300	0.100	0.358	0.25	28.320	380	343	472	0.171

Laying condition: Maximum conductor temperature 90°C, Ambient temperature 30°C. Underground temperature of soil 20°C, Depth of laying - 0.8m. Ground thermal resistivity 1.5 K.m/W, thermal resistivity of earthenware ducts 1.2 K.m/W.

Note: Area of copper wire considered is 16 mm² up to 120 mm², 25 mm² from 150 mm² up to 300 mm², 35 mm² from 400 mm² up to 630 mm².



**Current Carrying Capacity for Aluminium Wire Armoured Cables with Single Point Bonding
CU/XLPE/AWA/PVC 3.5/6kV to 18/30kV**

IEC		
Current Carrying Capacity (2)		
Size	Direct Buried	In Air
mm ²	Amps	Amps
25	138	162
35	165	197
50	195	236
70	236	294
95	282	358
120	322	415
150	359	472
185	406	541
240	469	640
300	527	734
400	604	858
500	667	973
630	747	1114

**Current Carrying Capacity for Aluminium Wire Armoured Cables with Single Point Bonding
AL/XLPE/AWA/PVC 3.5/6kV to 18/30kV**

IEC		
Current Carrying Capacity (2)		
Size	Direct Buried	In Air
mm ²	Amps	Amps
25	108	126
35	128	152
50	151	183
70	183	227
95	219	277
120	249	322
150	280	366
185	316	422
240	367	498
300	414	573
400	476	675
500	535	778
630	609	904



Derating Factors

Table 1: Correction Factors for Ambient Air Temperature

Maximum Conductor Temperature	Ambient Air Temperature (°C)							
	20	25	35	40	45	50	55	60
90 °C	1.08	1.04	0.96	0.91	0.87	0.82	0.76	0.71

Table 2: Correction Factors for Ambient Ground Temperature

Maximum Conductor Temperature	Temperature (°C)							
	10	15	25	30	35	40	45	50
90 °C	1.07	1.04	0.96	0.93	0.89	0.85	0.80	0.76

Table 3: Correction Factors for Depth of Laying

Depth of Laying (m)	Single Core Cables		Three-Core Cables
	Nominal Conductor Size		
	≤ 185 mm ²	> 185 mm ²	
0.5	1.04	1.06	1.04
0.6	1.02	1.04	1.03
1	0.98	0.97	0.98
1.25	0.96	0.95	0.96
1.5	0.95	0.93	0.95
1.75	0.94	0.91	0.94
2	0.93	0.90	0.93
2.5	0.91	0.88	0.91
3	0.90	0.86	0.90



Derating Factors

Table 4: Correction Factors for Depth of Laying for Cables in Ducts

Depth of Laying (m)	Single Core Cables		Three-Core Cables
	Nominal Conductor Size		
	$\leq 185 \text{ mm}^2$	$> 185 \text{ mm}^2$	
0.5	1.04	1.05	1.03
0.6	1.02	1.03	1.02
1	0.98	0.97	0.99
1.25	0.96	0.95	0.97
1.5	0.95	0.93	0.96
1.75	0.94	0.92	0.95
2	0.93	0.91	0.94
2.5	0.91	0.89	0.93
3	0.90	0.88	0.92

Table 5: Correction Factors for Soil Thermal Resistivities other than 1.5 k.m/W for Direct Buried Single-Core Cable

Nominal area of Conductor mm ²	Values of Soil Thermal Resistivity K.m/W						
	0.7	0.8	0.9	1	2	2.5	3
16	1.29	1.24	1.19	1.15	0.89	0.82	0.75
25	1.30	1.25	1.20	1.16	0.89	0.81	0.75
35	1.30	1.25	1.21	1.16	0.89	0.81	0.75
50	1.32	1.26	1.21	1.16	0.89	0.81	0.74
70	1.33	1.27	1.22	1.17	0.89	0.81	0.74
95	1.34	1.28	1.22	1.18	0.89	0.80	0.74
120	1.34	1.28	1.22	1.18	0.88	0.80	0.74
150	1.35	1.28	1.23	1.18	0.88	0.80	0.74
185	1.35	1.29	1.23	1.18	0.88	0.80	0.74
240	1.36	1.29	1.23	1.18	0.88	0.80	0.73
300	1.36	1.30	1.24	1.19	0.88	0.80	0.73
400	1.37	1.30	1.24	1.19	0.88	0.79	0.73



Derating Factors

Table 6: Correction Factors for Thermal Resistivities other than 1.5 K.m/W for Single-Core Cables in Buried Ducts

Nominal Area of Conductor	Values of Soil Thermal Resistivity K.m/W						
	0.7	0.8	0.9	1	2	2.5	3
mm ²							
16	1.20	1.17	1.14	1.11	0.92	0.85	0.79
25	1.21	1.17	1.14	1.12	0.91	0.85	0.79
35	1.21	1.18	1.15	1.12	0.91	0.84	0.79
50	1.21	1.18	1.15	1.12	0.91	0.84	0.78
70	1.22	1.19	1.15	1.12	0.91	0.84	0.78
95	1.23	1.19	1.16	1.13	0.91	0.84	0.78
120	1.23	1.20	1.16	1.13	0.91	0.84	0.78
150	1.24	1.20	1.16	1.13	0.91	0.83	0.78
185	1.24	1.20	1.17	1.13	0.91	0.83	0.78
240	1.25	1.21	1.17	1.14	0.90	0.83	0.77
300	1.25	1.21	1.17	1.14	0.90	0.83	0.77
400	1.25	1.21	1.17	1.14	0.90	0.83	0.77

Table 7: Correction Factors for Thermal Resistivities other than 1.5 K.m/W for Three –Core Cables Direct Buried

Nominal Area of Conductor	Values of Soil Thermal Resistivity K.m/W						
	0.7	0.8	0.9	1	2	2.5	3
mm ²							
16	1.23	1.19	1.16	1.13	0.91	0.84	0.78
25	1.24	1.20	1.16	1.13	0.91	0.84	0.78
35	1.25	1.21	1.17	1.13	0.91	0.83	0.78
50	1.25	1.21	1.17	1.14	0.91	0.83	0.77
70	1.26	1.21	1.18	1.14	0.90	0.83	0.77
95	1.26	1.22	1.18	1.14	0.90	0.83	0.77
120	1.26	1.22	1.18	1.14	0.90	0.836	0.77
150	1.27	1.22	1.18	1.15	0.90	0.83	0.77
185	1.27	1.23	1.18	1.15	0.90	0.83	0.77
240	1.28	1.23	1.19	1.15	0.90	0.83	0.77
300	1.28	1.23	1.19	1.15	0.90	0.82	0.77
400	1.28	1.23	1.19	1.15	0.90	0.82	0.76



Derating Factors

Table 8: Correction Factors for Soil Thermal Resistivities other than 1.5Km/W for Three –Core Cables in Ducts

Nominal Area of Conductor mm ²	Values of Soil Thermal Resistivity K.m/W						
	0.7	0.8	0.9	1	2	2.5	3
16	1.12	1.11	1.09	1.08	0.94	0.89	0.84
25	1.14	1.12	1.10	1.08	0.94	0.89	0.84
35	1.14	1.12	1.10	1.08	0.94	0.88	0.84
50	1.14	1.12	1.10	1.08	0.94	0.88	0.84
70	1.15	1.13	1.11	1.09	0.94	0.88	0.83
95	1.15	1.13	1.11	1.09	0.94	0.88	0.83
120	1.15	1.13	1.11	1.09	0.93	0.88	0.83
150	1.16	1.13	1.11	1.09	0.93	0.88	0.83
185	1.16	1.14	1.11	1.09	0.93	0.87	0.83
240	1.16	1.14	1.12	1.10	0.93	0.87	0.82
300	1.17	1.14	1.12	1.10	0.93	0.87	0.82
400	1.17	1.14	1.12	1.10	0.92	0.86	0.81

Table 9 : Correction Factors for Groups of Three –Core Cables in Horizontal Formation Laid in the Ground

Number of Cables in Group	Spacing Between Cable Centres				
	Touching	200	400	600	800
2	0.80	0.86	0.90	0.92	0.94
3	0.69	0.77	0.82	0.86	0.89
4	0.62	0.72	0.79	0.83	0.87
5	0.57	0.68	0.76	0.81	0.85
6	0.54	0.65	0.74	0.80	0.84
7	0.51	0.63	0.72	0.78	0.83
8	0.49	0.61	0.71	0.78	-
9	0.47	0.60	0.70	0.77	-
10	0.46	0.59	0.69	-	-
11	0.45	0.57	0.69	-	-
12	0.43	0.56	0.68	-	-



Derating Factors

Table 10: Correction Factors for Groups of Three Phase Circuits of Single Core Cables Laid Direct in the Ground

Number of Cables in Group	Spacing Between Cable Centers				
	Touching	200	400	600	800
2	0.73	0.83	0.88	0.90	0.92
3	0.60	0.73	0.79	0.83	0.86
4	0.54	0.68	0.75	0.80	0.84
5	0.49	0.63	0.72	0.78	0.82
6	0.46	0.61	0.70	0.76	0.81
7	0.43	0.58	0.68	0.75	0.80
8	0.41	0.57	0.67	0.74	-
9	0.39	0.55	0.66	0.73	-
10	0.37	0.54	0.65	-	-
11	0.36	0.53	0.64	-	-
12	0.35	0.52	0.64	-	-

Table 11: Correction Factors for Groups of Three –Core Cables in Single way Ducts in Horizontal Formation.

Number of Cables in Group	Spacing Between Cable Centers				
	Touching	200	400	600	800
2	0.85	0.88	0.92	0.94	0.95
3	0.75	0.80	0.85	0.88	0.91
4	0.69	0.75	0.82	0.86	0.89
5	0.65	0.72	0.79	0.84	0.87
6	0.62	0.69	0.77	0.83	0.87
7	0.59	0.67	0.76	0.82	0.86
8	0.57	0.65	0.75	0.81	-
9	0.55	0.64	0.74	0.80	-
10	0.54	0.63	0.73	-	-
11	0.52	0.62	0.73	-	-
12	0.51	0.61	0.72	-	-



Derating Factors

Table 12: Correction Factors for Groups for Three Phase Circuits of Single Core Cables in Single Way Ducts

Number of Cables in Group	Spacing Between Cable Centres				
	Touching	200	400	600	800
2	0.78	0.85	0.89	0.91	0.93
3	0.66	0.75	0.81	0.85	0.88
4	0.59	0.70	0.77	0.82	0.86
5	0.55	0.66	0.74	0.80	0.84
6	0.51	0.64	0.72	0.78	0.83
7	0.48	0.61	0.71	0.77	0.82
8	0.46	0.60	0.70	0.76	-
9	0.44	0.58	0.69	0.76	-
10	0.43	0.57	0.68	-	-
11	0.42	0.56	0.67	-	-
12	0.40	0.55	0.67	-	-

Table 13: Max. Short Circuit Current For Copper Conductors at 1 Sec.

Construction	Cond. Max Temp Normal Operation	Short Circuit Conductor Max Temp	Conductor Temp. at the beginning of short circuit								
			90	80	70	65	60	50	40	30	20
	°C	°C	Short Circuit Current (A/mm ²)								
XLPE Cable	90	250	143	149	154	157	159	165	170	176	181

Table 14: Max. Short Circuit Current For Aluminium Conductors at 1 Sec.

Construction	Cond. Max Temp Normal Operation	Short Circuit Conductor Max Temp	Conductor Temp. at the beginning of short circuit								
			90	80	70	65	60	50	40	30	20
	°C	°C	Short Circuit Current (A/mm ²)								
XLPE Cable	90	250	94	98	102	104	105	109	113	116	120

Isc for time (t) can be obtained from the following formula:

$$I_{sc}(t) = \frac{I_{sc}(1)}{\sqrt{t}}$$

Where: I_{sc} (1) = short circuit current at 1 sec.

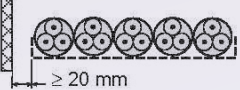
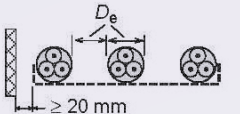
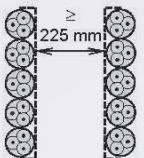
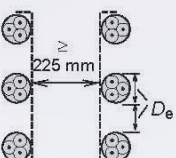
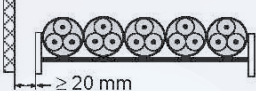
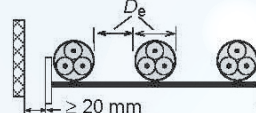

**Table 15: Reduction Factors for groups of more than one multi-core cable in air -
To be applied to the current-carrying capacity for one multi-core cable in free air**

Method of installation		Number of trays	Number of cables					
			1	2	3	4	6	9
Cables on perforated trays	Touching 	1	1,00	0,88	0,82	0,79	0,76	0,73
		2	1,00	0,87	0,80	0,77	0,73	0,68
		3	1,00	0,86	0,79	0,76	0,71	0,66
	Spaced 	1	1,00	1,00	0,98	0,95	0,91	-
		2	1,00	0,99	0,96	0,92	0,87	-
		3	1,00	0,98	0,95	0,91	0,85	-
Cables on vertical perforated trays	Touching 	1	1,00	0,88	0,82	0,78	0,73	0,72
		2	1,00	0,88	0,81	0,76	0,71	0,70
	Spaced 	1	1,00	0,91	0,89	0,88	0,87	-
		2	1,00	0,91	0,88	0,87	0,85	-
Cables on ladder supports, cleats, etc.	Touching 	1	1,00	0,87	0,82	0,80	0,79	0,78
		2	1,00	0,86	0,80	0,78	0,76	0,73
		3	1,00	0,85	0,79	0,76	0,73	0,70
	Spaced 	1	1,00	1,00	1,00	1,00	1,00	-
		2	1,00	0,99	0,98	0,97	0,96	-
		3	1,00	0,98	0,97	0,96	0,93	-

NOTE 1 Values given are averages for the cable types and range of conductor sizes considered. The spread of values is generally less than 5 %.

NOTE 2 Factors apply to single layer groups of cables as shown above and do not apply when cables are installed in more than one layer touching each other. Values for such installations may be significantly lower and must be determined by an appropriate method.

NOTE 3 Values are given for vertical spacings between trays of 300 mm and at least 20 mm between trays and wall. For closer spacing, the factors should be reduced.

NOTE 4 Values are given for horizontal spacing between trays of 225 mm with trays mounted back to back. For closer spacing, the factors should be reduced.

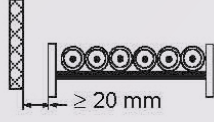
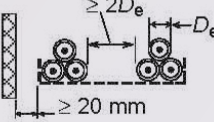
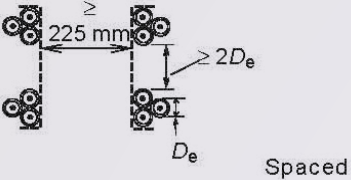
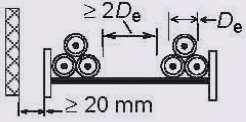

Table 16: Reduction Factors for groups of more than one circuit of single-core cable (Note 2) - To be applied to the current-carrying capacity for one circuit of single-core cable in free air

Method of installation		Number of trays	Number of three-phase circuits (Note 5)			Use as a multiplier to rating for
			1	2	3	
Perforated trays (Note 3)	 <p>Touching</p>	1	0,98	0,91	0,87	Three cables in horizontal formation
		2	0,96	0,87	0,81	
		3	0,95	0,85	0,78	
Ladder supports, cleats etc. (Note 3)	 <p>Touching</p>	1	1,00	0,97	0,96	Three cables in horizontal formation
		2	0,98	0,93	0,89	
		3	0,97	0,90	0,86	
Perforated trays (Note 3)		1	1,00	0,98	0,96	Three cables in horizontal formation
		2	0,97	0,93	0,89	
		3	0,96	0,92	0,86	
Vertical perforated trays (Note 4)	 <p>Spaced</p>	1	1,00	0,91	0,89	Three cables in trefoil formation
		2	1,00	0,90	0,86	
Ladder supports, cleats, etc. (Note 3)		1	1,00	1,00	1,00	Three cables in trefoil formation
		2	0,97	0,95	0,93	
		3	0,96	0,94	0,90	

NOTE 1 Values given are averages for the cable types and range of conductor sizes considered. The spread of values is generally less than 5 %.

NOTE 2 Factors are given for single layers of cables (or trefoil groups) as shown in the table and do not apply when cables are installed in more than one layer touching each other. Values for such installations may be significantly lower and should be determined by an appropriate method.

NOTE 3 Values are given for vertical spacings between trays of 300 mm. For closer spacing, the factors should be reduced.

NOTE 4 Values are given for horizontal spacing between trays of 225 mm with trays mounted back to back. For closer spacing, the factors should be reduced.

NOTE 5 For circuits having more than one cable in parallel per phase, each three phase set of conductors should be considered as a circuit for the purpose of this table.



**Permissible short circuit current of XLPE insulated power cables for 1 – 30 kV
(COPPER CONDUCTOR)**

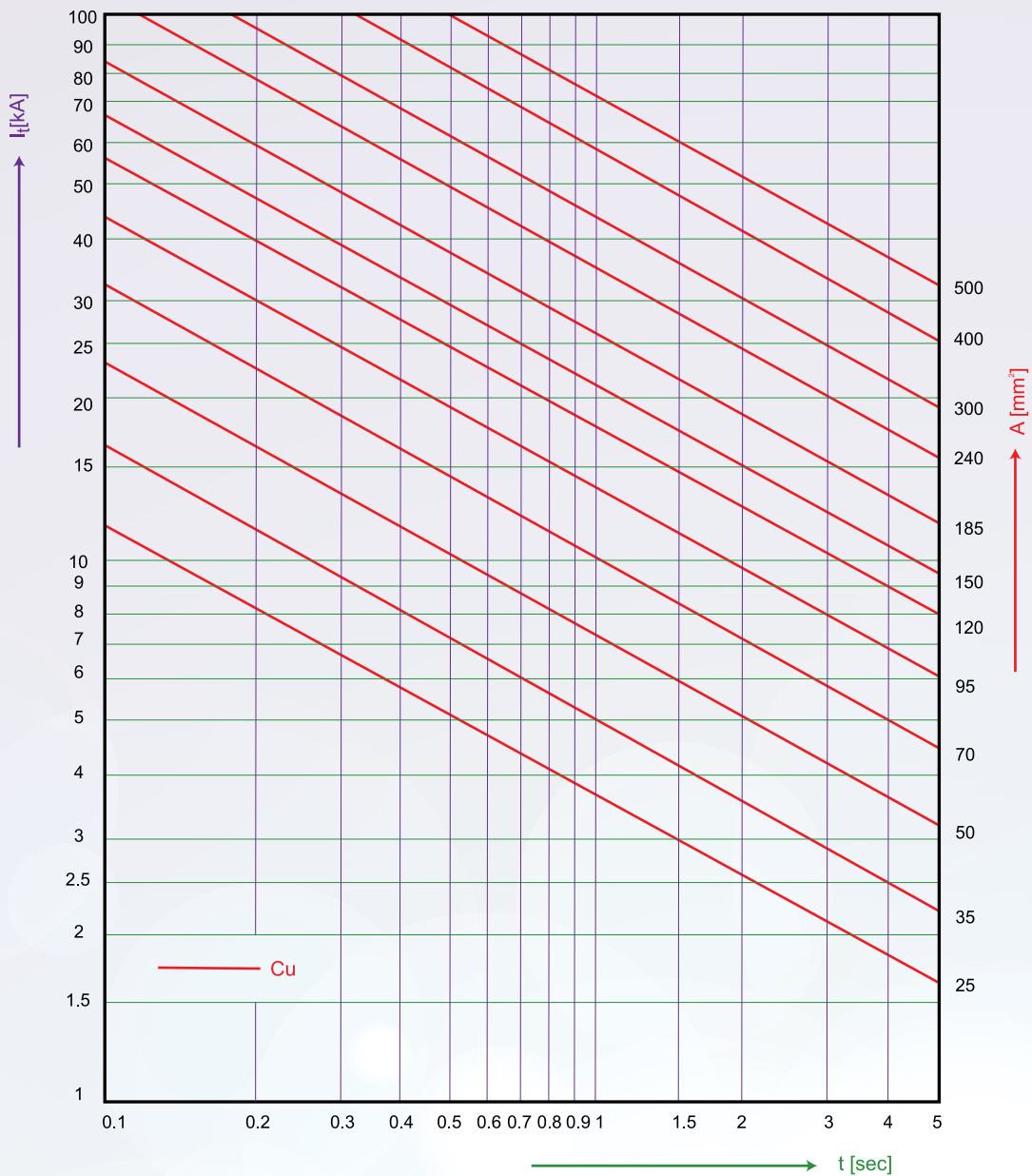

**Permissible short circuit current of XLPE insulated power cables for 1 – 30 kV
(ALUMINIUM CONDUCTOR)**

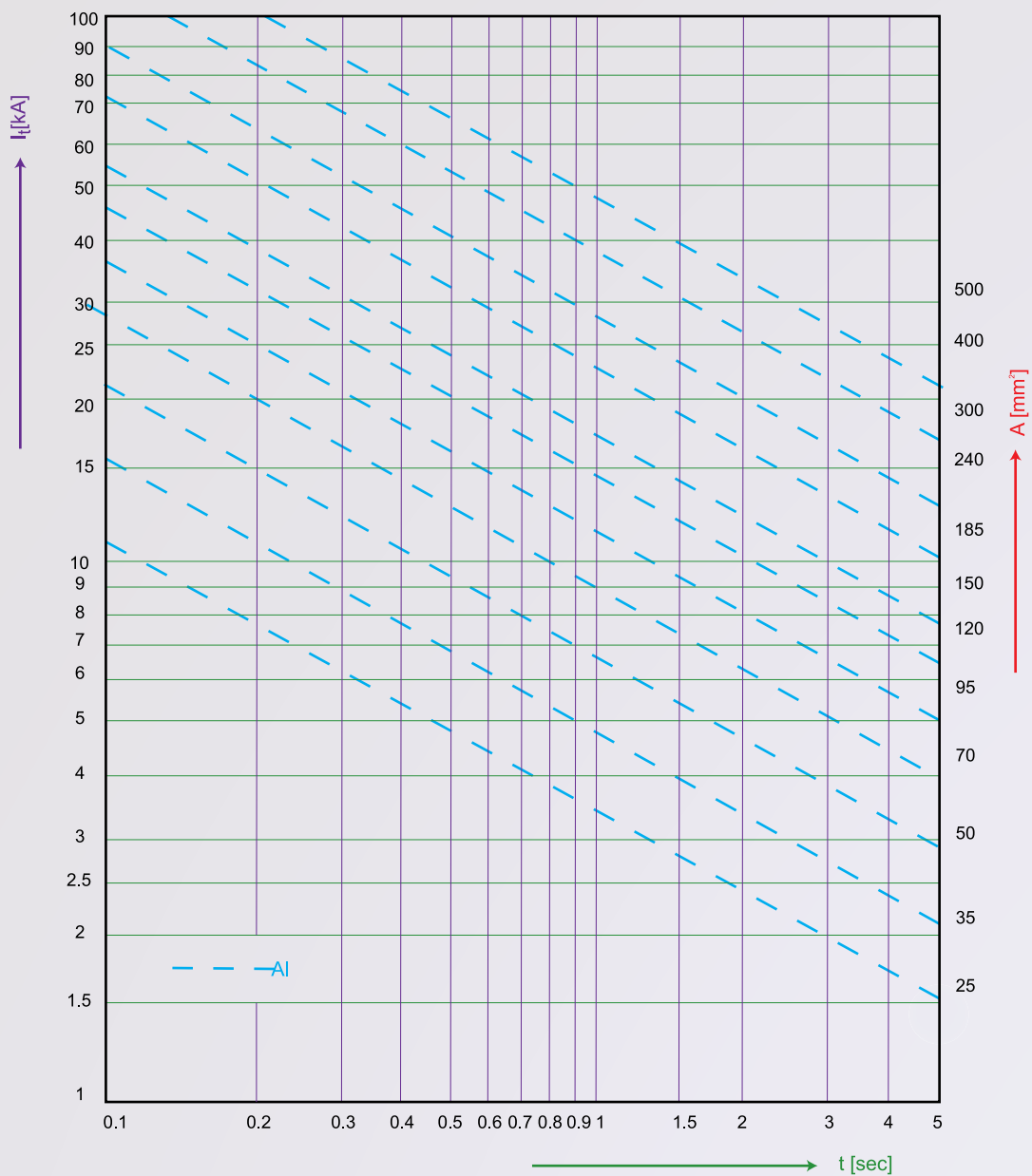

Permissible short circuit current for Various cross section of round wire screens

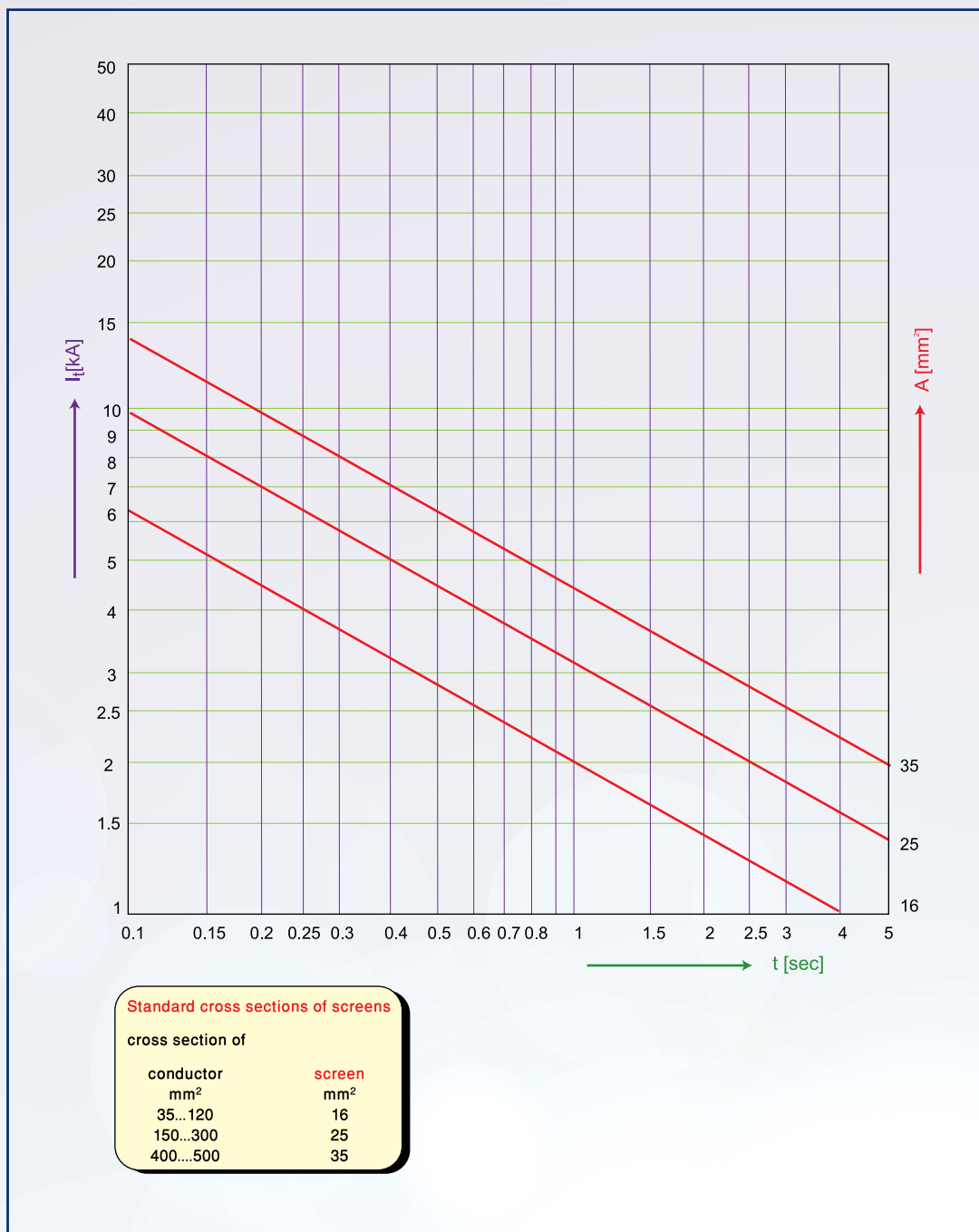

CABLE PULLING, LAYING AND HANDLING INSTRUCTION

(a) DRUM HANDLING

- 1) Unloading the drum should be by forklift or crane, rolling should be avoided.
- 2) If the above equipment are not available, rolling as per direction on special constructed ramps is allowed with a slope of $\frac{1}{4}$ ($\varnothing=14$ degrees).
- 3) Drum should not be dropped on the ground under any circumstances even on soft material.
- 4) Drums should be kept in the up-right position.
- 5) Be sure that the end seal cap is still in place.
- 6) Drums should be covered all the time.

(b) PREPARATION, CABLE PULLING AND LAYING

- 1) Is it recommended to dig a trial hole in the cable route, which shall indicate the position of other services, and a smooth bend can be provided to reduce the pulling load on the cable.
- 2) Cable should be inspected before laying to ensure that it is damage free.
- 3) Location of drum prior to pulling can be decided based on minimum pulling tension, which can be achieved.
- 4) Drums should be normally mounted so that the cable is pulled from the top of the drum and for very heavy cables it may be necessary to use a ramp to support the cable during passage into the trench. When cables have significant stiffness, e.g. those with HDPE outer sheaths, it may be preferable to pull from the bottom to reduce the tendency for the cable to come off with a wavy or spiral profile.
- 5) The cable should preferably be drawn to its final position in a continuous manner. During stops, it will settle between rollers and may cause high strain on machines during re-starting.
- 6) When pulling cables beside existing cables, special care should be taken to avoid damage to the existing cables.
- 7) Precautions should be taken such as clearing all excavated material from the trench edges, using vertical timbers etc., so that no stones or sharp objects shall fall onto the cable.
- 8) Minimum permissible bending radius shall be as per Table-17.
- 9) Maximum pulling tension should be as per Table-18.
- 10) Side wall pressure at the bend should not be exceeded.
- 11) Remember always that cable is a high commodity value and it is very sensitive to damage and must be handled with necessary care.
- 12) Possibility of braking the drum anytime should be prepared as in sudden stoppage of cable pulling. Continuation of drum rotation can cause sharp bending of the cable.
- 13) During pulling the inner end of the cable might be projected more and more, then it is necessary to interrupt the cable pulling from time to time in such cases for re-securing the said end.
- 14) Depth of laying shall be minimum 0.6 meters under footpath and 0.8 meters under roads for Low Voltage and Medium Voltage cables while it shall be around 1.5 meters for High Voltage Cables.



CABLE PULLING, LAYING AND HANDLING INSTRUCTION

- 15) Layer of sand 10 cm approx. under and over the cable shall be furnished. Then a layer of brick or tile shall be placed for warning, mechanical protection, load distribution.
- 16) When pulling the cable inside conduit/pipe the inner diameter of the pipe shall be min. 1.5 times the cable diameter.
- 17) It is preferable to use pipe with funnel shape, cable should not rest at the sharp edges of the pipe, special care should be taken such that stones and other objects are not dragged with the cable inside the pipe.
- 18) Pipe should be cleaned before pulling operation.
- 19) Special lubricant can be used to minimize the cable friction with the pipe wall.
- 20) When cables of different voltages are laid together it is preferable that the higher voltage to be laid down, then the lower voltage and then the lower voltage. High voltage cables should be separated by a covering slab from the other cables.
- 21) For direct buried installations, rollers at a distance of around 1 – 2 meters are to be used based on cable weight, in any case cable should not touch the ground. It is recommended to use motorized rollers at the distance of 20 M to 30 M with proper monitoring. These are beside the normal cable rollers specially near bending points so that the cable pulling force shall be distributed evenly over the complete length of the cable. This kind of pulling is recommended when there are many bends in the cable route.
- 22) For cable pulling, cable stocking can be used for Steel Wire armoured cables while for non-armoured cables Steel Tape armoured cables pulling head is preferred. Special care shall be taken to seal the cable head avoiding water penetration during pulling.
- 23) It is not advisable to use cable pulling stocking when the ambient temperature is around 45°C or more and under direct sunlight as the outer jacket might soften and get damaged.
- 24) It is recommended to use pulling head when the cable is pulled inside pipes or conduits as slipping of stocking might occur inside the pipe or conduit.
- 25) While pulling, continuous monitoring of the tensile force should be maintained.
- 26) At the bend, cable shall be guided by rollers. Direct touch with trench wall shall be completely avoided.
- 27) Immediately after cutting, the cable ends must be suitably sealed so that there is no ingress of moisture.
- 28) It is recommended to inspect the cable after laying to ensure that the cable has not been damaged.
- 29) Cable after laying should not be straightened but left with slight meandering to allow longitudinal expansion and contraction during thermal cycling.
- 30) When the ground water table is high it is advisable to use special cable construction with longitudinal and radial watertight characteristics.



CABLE PULLING, LAYING AND HANDLING INSTRUCTION

(c) CONSIDERATION FOR CABLE CURRENT RATING:

When laying cables special attention should be given to:

- 1) Cable Spacing
- 2) Any other cable passing by, in parallel or crossing as this might affect considerably the cable rating.
- 3) Any other heat source which might be near the cable as this shall have the same effect as point no. 2
- 4) Drying effect of soil on the value of soil thermal resistivity and side effects on current rating.
- 5) Avoid connecting the armour and sheath at both ends for single core cables as this shall reduce the current rating of the cables considerably but special attention should be given to induced voltage in both normal operation and short circuit.
- 6) The deeper the cables are laid lower is the ampacity of cables.
- 7) If cables are passing through pipes for more than 6 meters then the pipe derating factor should be considered.
- 8) Avoid pulling single core cable inside steel pipe or any other magnetic material, as this shall cause high losses and cable overheating.
- 9) Soil thermal resistivity of the actual ground at different places of the trench shall be measured to ensure that the value is matching the one used for current rating computation.

Table 17: Installation Bending Radius for Medium Voltage Cables

XLPE Insulated Vables 6.6 kV to 33 KV

Type of Cable	Minimum Radius	
	During Laying	Adjacent to joints or terminations
Single Core:		
(a) Unarmoured	20 X D	15 X D
(b) Armoured (PVC)	15 X D	12 X D
(c) Armoured (PE)	20 X D	15 X D
Three Core:		
(d) Unarmoured	15 X D	12 X D
(e) Armoured (PVC)	12 X D	10 X D
(f) Armoured (PE)	15 X D	12 X D



Table 18: Permissible Pulling Force in the Laying of MV Cables

Means of Pulling	Type of Cable	Formula	Factor
With pulling head attached to the Conductor	All types of cables	$P = \sigma \cdot A$	$\sigma = 50 \text{ N/mm}^2$ (Copper Conductor) $\sigma = 30 \text{ N/mm}^2$ (Aluminium Conductor)
With pulling stocking	Un-armoured Cables*	$P = \sigma \cdot A$	$\sigma = 50 \text{ N/mm}^2$ (Copper Conductor) $\sigma = 30 \text{ N/mm}^2$ (Aluminium Conductor)
	Armoured cables	$P = k \cdot d^2$	$k = 9 \text{ N/mm}^2$

*When pulling 3 single core cables simultaneously with a common pulling stocking, the same maximum pulling force applies, whereas the pulling force 3 laid-up single core cables is 3 times that of a single core and for 3 non-laid-up single core cables is 2 times that of a single core.

Where:

- P = Pull in Newtons
- A = Total cross sectional area in mm² of all conductors (but not screen or concentric conductor)
- d = Outside diameter of the cable in mm
- σ = Permissible tensile stress of conductor in N/mm²
- k = Empirically derived factor in N/mm²

Table 19: Permissible Radial Load Values

Permissible radial loads for pulling through plastic pipes	
Non-Armoured Cables	10000 N/m
Cables with Single Armour	15000 N/m
Maximum permissible loads on rollers fitted on bends	
Non-Armoured Cables	1500 N/m
Cables with Single Armour	2500 N/m
When using roller chain (5 rollers / m)	
Non-Armoured Cables	7500 N/m
Cables with Single Armour	12500 N/m
When only 3 rollers / m are fitted	
Non-Armoured Cables	4500 N/m
Cables with Single Armour	7500 N/m





P.O. Box: 27472 Sharjah U.A.E.
Tel.: +971 6 5311888 (8 Lines) Fax.: +971 6 5311577
e-mail: n_c_i@emirates.net.ae website: www.nci.ae

NATIONAL CABLES INDUSTRY **NCI** الوطنية لصناعة الكابلات

Committed Quality for our Customers



CONTROL CABLES



DUBAI QUALITY APPRECIATION PROGRAM

INNOVATIVE
PROCESSES AND
TECHNOLOGY STRATEGIES



P.O.Box: 27472 Sharjah U.A.E
Tel. +971 6 5311 888 | Fax. +971 6 5311 577
e.mail: n_c_i@emirates.net.ae

SateLite
DUBAI
Tel.: +971 6 556 5807

0.6/1 kV LOW VOLTAGE CONTROL CABLES

PVC OR XLPE INSULATED, PVC SHEATHED AS PER IEC 60502-1

Conductors

Conductors shall be Circular Stranded, Class 2 as per IEC 60228, BS EN 60228. Upon request, Solid Circular Conductor, Class 1 as per IEC 60228, BS EN 60228 can be supplied.

Insulation

XLPE material and thickness shall be as per IEC 60502-1 rated 90°C for continuous operation or

PVC Insulation Type A as per IEC 60502-1 or T11 as per BS 7655 rated 70 °C for continuous operation.

Assembly

The Insulated Conductors are laid-up together with non-hygroscopic fillers wherever necessary, the assembly is bedded with an extruded layer of PVC. In case of non-armoured cables, this layer may be omitted provided the outer shape of the cable remains practically circular.

Standard Colour Code

Single core	: Red or Black
Two cores	: Red, Black
Three cores	: Red, Yellow, Blue
Four cores	: Red, Yellow, Blue, Black
Five cores	: Red, Yellow, Blue, Black, Green
Six cores & above	: White numerals printed on black core insulation.

Armour (Optional)

- Galvanized Steel Wires applied helically over the bedding as per IEC 60502-1 (or BS 5467, BS 6346 as per customer requirements).
- Double Steel Tapes applied helically over the bedding as per IEC 60502-1.

Screening (Optional)

- Copper Tape(s) of nominal thickness 0.05mm applied helically with suitable overlap or as per customer requirement.
- Copper Wire Screen (upon request) as per customer requirement.

Outer Sheath

PVC Type ST2 as per IEC 60502-1 and Type 9 as per BS 7655 coloured Black.

Application

Underground direct or indirect on cable tray.



PARTICULARS & GUARANTEES RELATING TO PVC INSULATING COMPOUND (TYPE T11)

PARTICULARS & GUARANTEES RELATING TO PVC INSULATING COMPOUND (TYPE A)

SL. NO.	DESCRIPTION	UNIT	GUARANTEED PARTICULARS
1	Tensile Strength and Elongation at break: Min. tensile strength Min. elongation at break	N/mm ² %	12.5 125
2	Low temperature bend test: Temperature at which specimen shall not crack	°C	-15 ± 2
3	Low temperature elongation test: Test temperature Min. Elongation	°C %	-15 ± 2 30
4	Low temperature impact test: Temperature at which specimen Shall not crack	°C	-15 ± 2
5	Accelerated ageing for specified Period at specified temperature Followed by loss of mass test: Max. loss of mass, after ageing for 7 days at 80 ± 2 °C	Mg/cm ²	2.0
6	Accelerated ageing for specified period at specified temperature followed by tensile strength & elongation at break Number of days ageing Ageing temperature Tensile Strength after ageing: Min. value Max. variation Elongation at break after ageing: Min. value Max. variation from unaged value	Days °C N/mm ² % % %	7 80 ± 2 12.5 20 125 20
7	Pressure test at high temperature: Test temperature Max. indentation	°C %	80 ± 2 50
8	Resistance to cracking: Temperature at which specimen Shall not crack	°C	150 ± 2
9	Insulation resistance constant: Min. K. value at 70°C	M.Ω.km	0.037

SLNO.	DESCRIPTION	UNIT	GUARANTEED PARTICULARS
1	Tensile Strength and Elongation at break: Min. tensile strength Min. elongation at break	N/mm ² %	12.5 150
2	Low temperature bend test: Temperature at which specimen shall not track	°C	-15 ± 2
3	Low temperature elongation test: Test temperature Min. Elongation	°C %	-15 ± 2 20
4	Low temperature impact test: Test temperature Min. Elongation	°C	-
5	Accelerated ageing for specified Period at specified temperature Followed by loss of mass test: Max. loss of mass, after ageing for 7 days at 80 ± 2 °C	Mg/cm ²	-
6	Accelerated ageing for specified period at specified temperature followed by tensile strength & elongation at break Number of days ageing Ageing temperature Tensile Strength after ageing: Min. value Max. variation Elongation at break after ageing: Min. value Max. variation from unaged value	Days °C N/mm ² % % %	7 100 ± 2 12.5 25 150 25
7	Pressure test at high temperature: Test temperature Max. indentation	°C %	80 ± 2 50
8	Resistance to cracking: Temperature at which specimen Shall not crack	°C	150 ± 2
9	Insulation resistance constant: Min. K. value at 70°C	M.Ω.km	-



PVC OUTER SHEATH, XLPE INSULATION

STANDARD : IEC 60502-1

600/1000 VOLTS

PARTICULARS & GUARANTEES RELATING TO PVC OUTER SHEATH TYPE ST2 (IEC 60502), TYPE 9 (BS 7655)

PARTICULARS & GUARANTEES RELATING TO XLPE INSULATION

SL. NO.	DESCRIPTION	UNIT	GUARANTEED PARTICULARS
1	Tensile Strength and Elongation at break: Min. tensile strength Min. elongation at break	N/mm ² %	12.5 150
2	Low temperature bend test: Temperature at which specimen shall not crack	°C	-15±2
3	Low temperature elongation test: Test temperature Min. Elongation	°C %	-15±2 20
4	Low temperature impact test: Temperature at which specimen shall not crack	°C	-15±2
5	Loss of mass after ageing for 7 days: At 100±2 °C Max. loss of mass	mg/cm ²	1.5
6	Accelerated ageing for specified period at specified temperature followed by tensile strength and elongation at break Number of days ageing Ageing temperature Tensile Strength after ageing: Min. Value Max. variation Elongation at break after ageing: Min. Value Max. variation from un-aged value	°C N/mm ² %	7 100±2 12.5 25 150 25
7	Pressure test at high temperature: Test temperature Max. indention	°C %	90±2 50
8	Heat Shock Test: Temperature at which specimen shall not crack	°C	150±2
9	Insulation resistance constant: Min. K. value at 20°C	M.Ω.km	0.0035
10	Flame Retardancy test (if required)	As per IEC 60332-1 (upon request)	

SL. NO.	DESCRIPTION	UNIT	GUARANTEED PARTICULARS
1	Tensile Strength and Elongation at break: Min. tensile strength Min. elongation at break	N/mm ² %	12.5 200
2	Accelerated ageing for specified period at specified temperature followed by Tensile Strength & Elongation at break No. of days ageing Ageing temperature Max. variation of tensile strength from un-aged specimen Max. variation of elongation from un-aged specimen	Days °C % %	7 135±3 ±25 ±25
3	Hot Set Test: Treatment: - Temperature - Time under load - Mechanical stress Max. elongation under load Max. permanent elongation after cooling	°C Minutes N/cm ² % %	200±3 15 20 175 15
4	Water Absorption: Treatment: - Temperature - Duration Max. variation of mass	°C Days mg/cm ²	85±2 14 1.0
5	Maximum permissible shrinkage: Treatment: - Temperature - Duration Max. variation of shrinkage	°C Hours %	130±3 1 4
6	Insulation Resistance constant(Ki) at maximum rated temperature (90 °C)	M.Ω.km	3.67
7	Volume Resistivity at maximum rated temperature (90 °C)	Ω.cm	10 ¹²



CONTROL CABLES TO IEC 60502-1

COPPER CONDUCTORS, PVC INSULATED, PVC SHEATHED 600/1000 VOLTS

Cross sectional area of conductor : 1.5 mm² (Round Stranded)
 Thickness of insulation : 0.8 mm
 Conductor DC Resistance at 20°C : 12.1 Ohm/Km
 Thickness of copper tape screen : 0.05 mm (Applicable only for CU/PVC/CUT/PVC)

No.	CU/PVC/PVC				CU/PVC/SWA/PVC					CU/PVC/STA/PVC					CU/PVC/CUT/PVC			
	UNARMoured				STEEL WIRE ARMoured					STEEL TAPE ARMoured					COPPER TAPE SCREEN			
	Nom. Sheath Thickness	Approx. Overall Dia.	Approx. Weight	Packing	Nom. Steel Wire Dia.	Nom. Sheath Thickness	Approx. Overall Dia.	Approx. Weight	Packing	Steel Tape Thickness	Nom. Sheath Thickness	Approx. Overall Dia.	Approx. Weight	Packing	Nom. Sheath Thickness	Approx. Overall Dia.	Approx. Weight	Packing
mm	mm	Kg/Km	meters	mm	mm	mm	Kg/Km	meters	mm	mm	mm	Kg/km	meters	mm	mm	Kg/Km	meters	
2	1.8	12	200	1000	0.8	1.8	14	350	1000	0.2	1.8	13	260	1000	1.8	12	210	1000
3	1.8	12	220	1000	0.8	1.8	15	380	1000	0.2	1.8	13	290	1000	1.8	13	240	1000
4	1.8	13	250	1000	0.8	1.8	15	430	1000	0.2	1.8	14	330	1000	1.8	13	275	1000
5	1.8	14	300	1000	0.8	1.8	16	490	1000	0.2	1.8	15	375	1000	1.8	14	320	1000
7	1.8	15	350	1000	0.8	1.8	17	550	1000	0.2	1.8	16	430	1000	1.8	15	370	1000
10	1.8	18	450	1000	1.25	1.8	21	850	1000	0.2	1.8	19	550	1000	1.8	18	475	1000
12	1.8	19	500	1000	1.25	1.8	21	900	1000	0.2	1.8	20	620	1000	1.8	19	535	1000
14	1.8	20	560	1000	1.25	1.8	22	990	1000	0.2	1.8	20	675	1000	1.8	20	600	1000
16	1.8	20	625	1000	1.25	1.8	23	1070	1000	0.2	1.8	21	750	1000	1.8	21	660	1000
19	1.8	21	700	1000	1.6	1.8	25	1300	1000	0.2	1.8	22	825	1000	1.8	22	735	1000
24	1.8	25	875	1000	1.6	1.8	28	1575	1000	0.2	1.8	25	1020	1000	1.8	25	915	1000
27	1.8	25	950	1000	1.6	1.8	28	1675	1000	0.2	1.8	26	1100	1000	1.8	25	990	1000
30	1.8	26	1020	1000	1.6	1.8	29	1755	1000	0.2	1.8	27	1175	1000	1.8	26	1060	1000
37	1.8	28	1200	1000	1.6	1.9	31	2010	500	0.2	1.8	29	1370	1000	1.8	28	1250	1000
44	1.9	31	1390	500	1.6	2.0	34	2300	500	0.2	1.9	32	1570	500	1.9	31	1440	500
48	1.9	32	1490	500	2.0	2.0	36	2650	500	0.2	1.9	32	1675	500	1.9	32	1535	500
52	1.9	33	1620	500	2.0	2.1	37	2850	500	0.2	1.9	34	1820	500	1.9	33	1675	500
61	2.0	35	1900	500	2.0	2.1	39	3175	500	0.2	2.0	36	2120	500	2.0	35	1960	500

Core Identification:

- 2 Cores : Red, Black
- 3 Cores : Red, Yellow, Blue
- 4 Cores : Red, Yellow, Blue, Black
- 5 Cores : Red, Yellow, Blue, Black, Green
- 6 Cores and above : Black core insulation with White printed numerals.

Tolerance:

- Overall diameter: ± 5%
- Packing: ± 5%

Also available upon request:

- a) Solid (re) Conductors
- b) Control Cables with Copper Wire Screen
- c) Control Cables with one core Green/Yellow

Note:

- 1) Based on special request for 6 cores and above, white cores with black printed numerals can also be provided.
- 2) Cable with one core Green/Yellow can also be provided based on special request.



CONTROL CABLES TO IEC 60502-1

COPPER CONDUCTORS, PVC INSULATED, PVC SHEATHED 600/1000 VOLTS

Cross sectional area of conductor : 2.5 mm² (Round Stranded)
 Thickness of insulation : 0.8 mm
 Conductor DC Resistance at 20°C : 7.41 Ohm/Km
 Thickness of copper tape screen : 0.05 mm (Applicable only for CU/PVC/CUT/PVC)

No. of Cores	CU/PVC/PVC				CU/PVC/SWA/PVC					CU/PVC/STA/PVC					CU/PVC/CUT/PVC			
	UNARMoured				STEEL WIRE ARMoured					STEEL TAPE ARMoured					COPPER TAPE SCREEN			
	Nom. Sheath Thickness	Approx. Overall Dia.	Approx. Weight	Packing	Nom. Steel Wire Dia.	Nom. Sheath Thickness	Approx. Overall Dia.	Approx. Weight	Packing	Steel Tape Thickness	Nom. Sheath Thickness	Approx. Overall Dia.	Approx. Weight	Packing	Nom. Sheath Thickness	Approx. Overall Dia.	Approx. Weight	Packing
No.	mm	mm	Kg/Km	meters	mm	mm	mm	Kg/Km	meters	mm	mm	mm	Kg/km	meters	mm	mm	Kg/Km	meters
2	1.8	13	240	1000	0.8	1.8	15	400	1000	0.2	1.8	14	300	1000	1.8	13	255	1000
3	1.8	13	275	1000	0.8	1.8	16	450	1000	0.2	1.8	14	350	1000	1.8	14	300	1000
4	1.8	14	325	1000	0.8	1.8	16	515	1000	0.2	1.8	15	400	1000	1.8	15	350	1000
5	1.8	15	380	1000	0.8	1.8	17	590	1000	0.2	1.8	16	470	1000	1.8	16	400	1000
7	1.8	16	450	1000	1.25	1.8	19	800	1000	0.2	1.8	17	550	1000	1.8	17	475	1000
10	1.8	20	590	1000	1.25	1.8	23	1025	1000	0.2	1.8	21	700	1000	1.8	20	625	1000
12	1.8	21	665	1000	1.25	1.8	23	1110	1000	0.2	1.8	21	790	1000	1.8	21	700	1000
14	1.8	22	750	1000	1.6	1.8	25	1350	1000	0.2	1.8	22	875	1000	1.8	22	785	1000
16	1.8	23	840	1000	1.6	1.8	26	1475	1000	0.2	1.8	23	975	1000	1.8	23	875	1000
19	1.8	24	950	1000	1.6	1.8	27	1620	1000	0.2	1.8	24	1090	1000	1.8	24	990	1000
24	1.8	27	1200	1000	1.6	1.9	31	1990	1000	0.2	1.8	28	1350	1000	1.8	28	1235	1000
27	1.8	28	1300	1000	1.6	1.9	31	2120	500	0.2	1.8	29	1470	1000	1.8	28	1350	1000
30	1.8	29	1400	1000	1.6	1.9	32	2235	500	0.2	1.8	30	1575	1000	1.8	29	1450	1000
37	1.9	31	1675	500	1.6	2.0	34	2590	500	0.2	1.9	32	1870	500	1.9	31	1730	500
44	2.0	35	1975	500	2.0	2.1	39	3275	500	0.2	2.0	36	2190	500	2.0	35	2040	500
48	2.0	36	2120	500	2.0	2.1	40	3450	500	0.2	2.0	37	2340	500	2.0	36	2180	500
52	2.0	37	2210	500	2.0	2.2	41	3650	500	0.2	2.1	38	2515	500	2.0	37	2355	500
61	2.1	39	2675	500	2.0	2.2	43	4110	500	0.5	2.2	41	3300	500	2.1	39	2740	500

Core Identification:

2 Cores : Red, Black
 3 Cores : Red, Yellow, Blue
 4 Cores : Red, Yellow, Blue, Black
 5 Cores : Red, Yellow, Blue, Black, Green
 6 Cores and above : Black core insulation with White printed numerals.

Tolerance:

Overall diameter: ± 5%
 Packing: ± 5%

Also available upon request:

- a) Solid (re) Conductors
- b) Control Cables with Copper Wire Screen
- c) Control Cables with one core Green/Yellow

Note:

- 1) Based on special request for 6 cores and above, white cores with black printed numerals can also be provided.
- 2) Cable with one core Green/Yellow can also be provided based on special request.



CONTROL CABLES TO IEC 60502-1

COPPER CONDUCTORS, PVC INSULATED, PVC SHEATHED 600/1000 VOLTS

Cross sectional area of conductor : 4 mm² (Round Stranded)
 Thickness of insulation : 1.0 mm
 Conductor DC Resistance at 20°C : 4.61 Ohm/Km
 Thickness of copper tape screen : 0.05 mm (Applicable only for CU/PVC/CUT/PVC)

No.	CU/PVC/PVC				CU/PVC/SWA/PVC					CU/PVC/STA/PVC					CU/PVC/CUT/PVC			
	UNARMoured				STEEL WIRE ARMoured					STEEL TAPE ARMoured					COPPER TAPE SCREEN			
	Nom. Sheath Thickness	Approx. Overall Dia.	Approx. Weight	Packing	Nom. Steel Wire Dia.	Nom. Sheath Thickness	Approx. Overall Dia.	Approx Weight	Packing	Steel Tape Thickness	Nom. Sheath Thickness	Approx. Overall Dia.	Approx. Weight	Packing	Nom. Sheath Thickness	Approx. Overall Dia.	Approx. Weight	Packing
mm	mm	Kg/Km	meters	mm	mm	mm	Kg/Km	meters	mm	mm	mm	Kg/km	meters	mm	mm	Kg/Km	meters	
2	1.8	15	320	1000	0.8	1.8	17	515	1000	0.2	1.8	16	400	1000	1.8	15	350	1000
3	1.8	15	375	1000	1.25	1.8	18	700	1000	0.2	1.8	16	465	1000	1.8	16	400	1000
4	1.8	17	450	1000	1.25	1.8	19	800	1000	0.2	1.8	17	550	1000	1.8	17	475	1000
5	1.8	18	540	1000	1.25	1.8	20	925	1000	0.2	1.8	19	640	1000	1.8	18	570	1000
7	1.8	19	640	1000	1.25	1.8	22	1050	1000	0.2	1.8	20	750	1000	1.8	19	675	1000
10	1.8	24	850	1000	1.6	1.8	27	1535	1000	0.2	1.8	25	990	1000	1.8	24	890	1000
12	1.8	25	970	1000	1.6	1.8	28	1675	1000	0.2	1.8	25	1120	1000	1.8	25	1010	1000
14	1.8	26	1100	1000	1.6	1.8	29	1835	1000	0.2	1.8	26	1250	1000	1.8	26	1140	1000
16	1.8	27	1235	1000	1.6	1.8	30	2000	1000	0.2	1.8	28	1400	1000	1.8	27	1275	1000
19	1.8	28	1400	1000	1.6	1.9	32	2240	500	0.2	1.8	29	1575	1000	1.8	29	1450	1000
24	1.9	34	1820	500	2.0	2.1	38	3075	500	0.2	2.0	35	2035	500	1.9	34	1875	500
27	2.0	34	2000	500	2.0	2.1	39	3275	500	0.2	2.0	35	2220	500	2.0	35	2065	500
30	2.0	36	2160	500	2.0	2.1	40	3460	500	0.2	2.0	36	2375	500	2.0	36	2225	500
37	2.1	38	2600	500	2.0	2.2	43	4010	500	0.5	2.2	41	3215	500	2.1	39	2665	500
44	2.2	43	3000	500	2.5	2.4	49	5050	500	0.5	2.3	45	3700	500	2.2	43	3075	500
48	2.3	44	3290	500	2.5	2.4	50	5350	500	0.5	2.3	46	3990	500	2.3	45	3370	500
52	2.3	46	3525	500	2.5	2.5	51	5650	250	0.5	2.4	48	4265	500	2.3	46	3600	500
61	2.4	49	4160	500	2.5	2.6	54	6415	250	0.5	2.5	51	4940	250	2.4	49	4250	500

Core Identification:

- 2 Cores : Red, Black
- 3 Cores : Red, Yellow, Blue
- 4 Cores : Red, Yellow, Blue, Black
- 5 Cores : Red, Yellow, Blue, Black, Green
- 6 Cores and above : Black core insulation with White printed numerals.

Tolerance:

- Overall diameter: ± 5%
- Packing: ± 5%

Also available upon request:

- a) Solid (re) Conductors
- b) Control Cables with Copper Wire Screen
- c) Control Cables with one core Green/Yellow

Note:

- 1) Based on special request for 6 cores and above, white cores with black printed numerals can also be provided.
- 2) Cable with one core Green/Yellow can also be provided based on special request.



CONTROL CABLES TO IEC 60502-1

COPPER CONDUCTORS, XLPE INSULATED, PVC SHEATHED 600/1000 VOLTS

Cross sectional area of conductor : 1.5 mm² (Round Stranded)
 Thickness of insulation : 0.7 mm
 Conductor DC Resistance at 20°C : 12.1 Ohm/Km
 Thickness of copper tape screen : 0.05 mm (Applicable only for CU/XLPE/CUT/PVC)

No. of Cores	CU/XLPE/PVC				CU/XLPE/SWA/PVC					CU/XLPE/STA/PVC					CU/XLPE/CUT/PVC			
	UNARMOURED				STEEL WIRE ARMoured					STEEL TAPE ARMoured					COPPER TAPE SCREEN			
	Nom. Sheath Thickness	Approx. Overall Dia.	Approx. Weight	Packing	Nom. Steel Wire Dia.	Nom. Sheath Thickness	Approx. Overall Dia.	Approx. Weight	Packing	Steel Tape Thickness	Nom. Sheath Thickness	Approx. Overall Dia.	Approx. Weight	Packing	Nom. Sheath Thickness	Approx. Overall Dia.	Approx. Weight	Packing
No.	mm	mm	Kg/Km	meters	mm	mm	mm	Kg/Km	meters	mm	mm	mm	Kg/km	meters	mm	mm	Kg/Km	meters
2	1.8	12	175	1000	0.8	1.8	14	325	1000	0.2	1.8	12	240	1000	1.8	12	200	1000
3	1.8	12	200	1000	0.8	1.8	14	350	1000	0.2	1.8	13	260	1000	1.8	12	220	1000
4	1.8	13	230	1000	0.8	1.8	15	400	1000	0.2	1.8	14	300	1000	1.8	13	250	1000
5	1.8	14	265	1000	0.8	1.8	16	450	1000	0.2	1.8	14	340	1000	1.8	14	290	1000
7	1.8	14	300	1000	0.8	1.8	17	500	1000	0.2	1.8	15	390	1000	1.8	15	325	1000
10	1.8	17	400	1000	1.25	1.8	20	765	1000	0.2	1.8	18	500	1000	1.8	18	425	1000
12	1.8	18	440	1000	1.25	1.8	20	820	1000	0.2	1.8	19	540	1000	1.8	18	465	1000
14	1.8	19	485	1000	1.25	1.8	21	890	1000	0.2	1.8	19	600	1000	1.8	19	515	1000
16	1.8	20	540	1000	1.25	1.8	22	965	1000	0.2	1.8	20	650	1000	1.8	20	575	1000
19	1.8	20	600	1000	1.25	1.8	23	1050	1000	0.2	1.8	21	725	1000	1.8	21	635	1000
24	1.8	23	750	1000	1.6	1.8	27	1420	1000	0.2	1.8	24	885	1000	1.8	24	785	1000
27	1.8	24	810	1000	1.6	1.8	27	1500	1000	0.2	1.8	25	950	1000	1.8	24	850	1000
30	1.8	25	865	1000	1.6	1.8	28	1570	1000	0.2	1.8	25	1010	1000	1.8	25	900	1000
37	1.8	26	1015	1000	1.6	1.8	30	1770	500	0.2	1.8	27	1175	1000	1.8	27	1060	1000
44	1.8	29	1150	1000	1.6	1.9	33	2010	500	0.2	1.8	30	1335	500	1.8	29	1200	500
48	1.8	30	1235	500	1.6	1.9	33	2100	500	0.2	1.9	31	1430	500	1.8	30	1285	500
52	1.9	31	1330	500	1.6	2.0	34	2225	500	0.2	1.9	31	1520	500	1.9	31	1385	500
61	1.9	33	1585	500	2.0	2.0	37	2800	500	0.2	1.9	34	1785	500	1.9	33	1640	500

Core Identification:

- 2 Cores : Red, Black
- 3 Cores : Red, Yellow, Blue
- 4 Cores : Red, Yellow, Blue, Black
- 5 Cores : Red, Yellow, Blue, Black, Green
- 6 Cores and above : Black core insulation with White printed numerals.

Tolerance:

- Overall diameter: ± 5%
- Packing: ± 5%

Also available upon request:

- a) Solid (re) Conductors
- b) Control Cables with Copper Wire Screen
- c) Control Cables with one core Green/Yellow

Note:

- 1) Based on special request for 6 cores and above, white cores with black printed numerals can also be provided.
- 2) Cable with one core Green/Yellow can also be provided based on special request.



CONTROL CABLES TO IEC 60502-1

COPPER CONDUCTORS, XLPE INSULATED, PVC SHEATHED 600/1000 VOLTS

Cross sectional area of conductor : 2.5 mm² (Round Stranded)
 Thickness of insulation : 0.7 mm
 Conductor DC Resistance at 20°C : 7.41 Ohm/Km
 Thickness of copper tape screen : 0.05 mm (Applicable only for CU/XLPE/CUT/PVC)

No. of Cores	CU/XLPE/PVC				CU/ XLPE /SWA/PVC					CU/ XLPE /STA/PVC				CU/ XLPE /CUT/PVC				
	UNARMoured				STEEL WIRE ARMoured					STEEL TAPE ARMoured				COPPER TAPE SCREEN				
	Nom. Sheath Thickness	Approx. Overall Dia.	Approx. Weight	Packing	Nom. Steel Wire Dia.	Nom. Sheath Thickness	Approx. Overall Dia.	Approx Weight	Packing	Steel Tape Thickness	Nom. Sheath Thick ness	Approx. Overall Dia.	Approx. Weight	Packing	Nom. Sheath Thickness	Approx. Overall Dia.	Approx. Weight	Packing
No.	mm	mm	Kg/Km	meters	mm	mm	mm	Kg/Km	meters	mm	mm	mm	Kg/km	meters	mm	mm	Kg/Km	meters
2	1.8	12	220	1000	0.8	1.8	15	375	1000	0.2	1.8	13	285	1000	1.8	13	235	1000
3	1.8	13	250	1000	0.8	1.8	15	420	1000	0.2	1.8	14	320	1000	1.8	13	270	1000
4	1.8	14	290	1000	0.8	1.8	16	475	1000	0.2	1.8	15	370	1000	1.8	14	315	1000
5	1.8	15	350	1000	0.8	1.8	17	535	1000	0.2	1.8	16	425	1000	1.8	15	365	1000
7	1.8	16	400	1000	1.25	1.8	18	730	1000	0.2	1.8	17	490	1000	1.8	16	425	1000
10	1.8	19	525	1000	1.25	1.8	22	940	1000	0.2	1.8	20	635	1000	1.8	19	550	1000
12	1.8	20	590	1000	1.25	1.8	22	1015	1000	0.2	1.8	21	700	1000	1.8	20	625	1000
14	1.8	21	660	1000	1.25	1.8	23	1100	1000	0.2	1.8	21	780	1000	1.8	21	700	1000
16	1.8	22	740	1000	1.6	1.8	25	1350	1000	0.2	1.8	22	865	1000	1.8	22	775	1000
19	1.8	23	830	1000	1.6	1.8	26	1470	1000	0.2	1.8	23	965	1000	1.8	23	875	1000
24	1.8	26	1040	1000	1.6	1.8	29	1885	1000	0.2	1.8	27	1200	1000	1.8	26	1080	1000
27	1.8	27	1130	1000	1.6	1.8	30	1875	500	0.2	1.8	27	1300	1000	1.8	27	1175	1000
30	1.8	27	1220	1000	1.6	1.9	31	2020	500	0.2	1.8	28	1380	1000	1.8	28	1265	1000
37	1.8	30	1450	1000	1.6	1.9	33	2315	500	0.2	1.8	30	1625	500	1.8	30	1500	500
44	1.9	33	1700	500	2.0	2.1	38	2965	500	0.2	2.0	34	1925	500	1.9	34	1760	500
48	1.9	34	1825	500	2.0	2.1	38	3110	500	0.2	2.0	35	2050	500	1.9	34	1875	500
52	2.0	35	1965	500	2.0	2.1	39	3265	500	0.2	2.0	36	2180	500	2.0	35	2025	500
61	2.0	37	2300	500	2.0	2.2	41	3700	500	0.2	2.1	38	2540	500	2.0	37	2360	500

Core Identification:

2 Cores : Red, Black
 3 Cores : Red, Yellow, Blue
 4 Cores : Red, Yellow, Blue, Black
 5 Cores : Red, Yellow, Blue, Black, Green
 6 Cores and above : Black core insulation with White printed numerals.

Tolerance:

Overall diameter: ± 5%
 Packing: ± 5%

Also available upon request:

- Solid (re) Conductors
- Control Cables with Copper Wire Screen
- Control Cables with one core Green/Yellow

Note:

- Based on special request for 6 cores and above, white cores with black printed numerals can also be provided.
- Cable with one core Green/Yellow can also be provided based on special request.



CONTROL CABLES TO IEC 60502-1

COPPER CONDUCTORS, XLPE INSULATED, PVC SHEATHED 600/1000 VOLTS

Cross sectional area of conductor : 4 mm² (Round Stranded)
 Thickness of insulation : 0.7 mm
 Conductor DC Resistance at 20°C : 4.61 Ohm/Km
 Thickness of copper tape screen : 0.05 mm (Applicable only for CU/XLPE/CUT/PVC)

No. of Cores	CU/XLPE/PVC				CU/XLPE/SWA/PVC				CU/XLPE/STA/PVC				CU/XLPE/CUT/PVC					
	UNARMoured				STEEL WIRE ARMoured				STEEL TAPE ARMoured				COPPER TAPE SCREEN					
	Nom. Sheath Thickness	Approx. Overall Dia.	Approx. Weight	Packing	Nom. Steel Wire Dia.	Nom. Sheath Thickness	Approx. Overall Dia.	Approx. Weight	Packing	Steel Tape Thickness	Nom. Sheath Thickness	Approx. Overall Dia.	Approx. Weight	Packing	Nom. Sheath Thickness	Approx. Overall Dia.	Approx. Weight	Packing
No.	mm	mm	Kg/Km	meters	mm	mm	mm	Kg/Km	meters	mm	mm	mm	Kg/km	meters	mm	mm	Kg/Km	meters
2	1.8	14	270	1000	0.8	1.8	16	450	1000	0.2	1.8	14	345	1000	1.8	14	290	1000
3	1.8	14	315	1000	0.8	1.8	16	500	1000	0.2	1.8	15	400	1000	1.8	14	335	1000
4	1.8	15	375	1000	0.8	1.8	17	580	1000	0.2	1.8	16	460	1000	1.8	15	400	1000
5	1.8	16	450	1000	1.25	1.8	19	790	1000	0.2	1.8	17	540	1000	1.8	16	475	1000
7	1.8	17	530	1000	1.25	1.8	20	900	1000	0.2	1.8	18	635	1000	1.8	18	560	1000
10	1.8	21	700	1000	1.6	1.8	25	1300	1000	0.2	1.8	22	825	1000	1.8	22	735	1000
12	1.8	22	800	1000	1.6	1.8	25	1420	1000	0.2	1.8	23	930	1000	1.8	22	835	1000
14	1.8	23	900	1000	1.6	1.8	26	1560	1000	0.2	1.8	24	1040	1000	1.8	23	940	1000
16	1.8	24	1015	1000	1.6	1.8	27	1700	1000	0.2	1.8	25	1150	1000	1.8	24	1050	1000
19	1.8	25	1150	1000	1.6	1.8	29	1875	1000	0.2	1.8	26	1300	1000	1.8	26	1200	1000
24	1.8	29	1450	1000	1.6	1.9	33	2300	500	0.2	1.8	30	1625	500	1.8	30	1500	1000
27	1.8	30	1585	1000	1.6	1.9	33	2450	500	0.2	1.9	31	1780	500	1.8	30	1635	500
30	1.9	31	1725	500	1.6	2.0	35	2635	500	0.2	1.9	32	1915	500	1.9	31	1775	500
37	1.9	34	2100	500	2.0	2.1	38	3350	500	0.2	2.0	35	2315	500	1.9	34	2150	500
44	2.1	38	2440	500	2.0	2.2	42	3850	500	0.5	2.1	40	3035	500	2.1	38	2500	500
48	2.1	39	2625	500	2.0	2.2	43	4050	500	0.5	2.2	41	3250	500	2.1	39	2690	500
52	2.1	40	2810	500	2.0	2.3	44	4300	500	0.5	2.2	42	3450	500	2.1	40	2880	500
61	2.2	42	3310	500	2.0	2.3	47	4850	500	0.5	2.3	45	4000	500	2.2	43	3385	500

Core Identification:

2 Cores : Red, Black
 3 Cores : Red, Yellow, Blue
 4 Cores : Red, Yellow, Blue, Black
 5 Cores : Red, Yellow, Blue, Black, Green
 6 Cores and above : Black core insulation with White printed numerals.

Tolerance:

Overall diameter: ± 5%
 Packing: ± 5%

Also available upon request:

- Solid (re) Conductors
- Control Cables with Copper Wire Screen
- Control Cables with one core Green/Yellow

Note:

- Based on special request for 6 cores and above, white cores with black printed numerals can also be provided.
- Cable with one core Green/Yellow can also be provided based on special request.



C CONTROL CABLES TO BS-5467

COPPER CONDUCTORS, XLPE INSULATED, STEEL WIRE ARMoured, PVC SHEATHED

Size	Nominal Thickness of XLPE insulation	Nominal Thickness of PVC bedding	Nominal steel wire diameter.	Nominal Thickness of outer sheath	Approx. overall diameter.	Approx. weight	Standard packing
mm ²	mm	mm	mm	mm	mm	Kg/Km	meters
2x1.5	0.6	0.8	0.9	1.3	12.1	300	1000
3x1.5	0.6	0.8	0.9	1.3	12.6	310	1000
4x1.5	0.6	0.8	0.9	1.3	13.3	340	1000
5x1.5	0.6	0.8	0.9	1.4	14.3	390	1000
7x1.5	0.6	0.8	0.9	1.4	15.2	450	1000
12x1.5	0.6	0.8	1.25	1.5	19.4	755	1000
19x1.5	0.6	0.8	1.25	1.6	22.4	965	1000
27x1.5	0.6	1.0	1.6	1.7	26.7	1430	1000
37x1.5	0.6	1.0	1.6	1.7	29.0	1690	500
48x1.5	0.6	1.0	1.6	1.8	32.7	2060	500

Size	Nominal Thickness of XLPE insulation	Nominal Thickness of PVC bedding	Nominal steel wire diameter.	Nominal Thickness of outer sheath	Approx. overall diameter.	Approx. weight	Standard packing
mm ²	mm	mm	mm	mm	mm	Kg/Km	meters
2x2.5	0.7	0.8	0.9	1.4	13.6	370	1000
3x2.5	0.7	0.8	0.9	1.4	14.1	380	1000
4x2.5	0.7	0.8	0.9	1.4	15.0	435	1000
5x2.5	0.7	0.8	0.9	1.4	16.1	490	1000
7x2.5	0.7	0.8	0.9	1.4	17.1	570	1000
12x2.5	0.7	0.8	1.25	1.6	22.4	975	1000
19x2.5	0.7	1.0	1.6	1.7	26.6	1465	1000
27x2.5	0.7	1.0	1.6	1.8	30.7	1900	1000
37x2.5	0.7	1.0	1.6	1.8	33.8	2290	500
48x2.5	0.7	1.2	2.0	2.0	39.3	3140	500

Size	Nominal Thickness of XLPE insulation	Nominal Thickness of PVC bedding	Nominal steel wire diameter.	Nominal Thickness of outer sheath	Approx. overall diameter.	Approx. weight	Standard packing
mm ²	mm	mm	mm	mm	mm	Kg/Km	meters
2x4	0.7	0.8	0.9	1.4	14.7	435	1000
3x4	0.7	0.8	0.9	1.4	15.3	460	1000
4x4	0.7	0.8	0.9	1.4	16.4	535	1000
5x4	0.7	0.8	0.9	1.5	17.8	620	1000
7x4	0.7	0.8	1.25	1.5	19.7	840	1000
12x4	0.7	1.0	1.6	1.6	25.7	1415	1000
19x4	0.7	1.0	1.6	1.7	29.3	1870	1000
27x4	0.7	1.0	1.6	1.9	34.4	2485	1000
37x4	0.7	1.2	2.0	2.0	39.2	3365	500
48x4	0.7	1.2	2.0	2.1	44.1	4115	500

Core identification:

- 2cores : Red, Black
- 3cores : Red, yellow, blue
- 4cores : Red, yellow, blue, black
- 5cores : Red, yellow, blue, black, green
- 6cores & above : black core insulation with white numerals

Tolerance:

- Overall diameter: ± 5%
- Packing : ± 5%

Note: 1) Based on special request solid (re)conductors can also be provided

2) Based on special request for 6cores and above, white cores with black printed numerals can also be provided

3) Cable with one core Green/Yellow can also be provided based on special request:



C CONTROL CABLES TO BS-6346

COPPER CONDUCTORS, PVC INSULATED, STEEL WIRE ARMoured, PVC SHEATHED

Size	Nominal Thickness of PVC insulation	Nominal Thickness of PVC bedding	Nominal steel wire diameter.	Nominal Thickness of outer sheath	Approx. overall diameter.	Approx. weight	Standard packing
mm ²	mm	mm	mm	mm	mm	Kg/Km	meters
2x1.5	0.6	0.8	0.9	1.4	12.3	300	1000
3x1.5	0.6	0.8	0.9	1.4	12.8	320	1000
4x1.5	0.6	0.8	0.9	1.4	13.5	360	1000
5x1.5	0.6	0.8	0.9	1.4	14.3	400	1000
7x1.5	0.6	0.8	0.9	1.4	15.2	460	1000
12x1.5	0.6	0.8	1.25	1.5	19.4	785	1000
19x1.5	0.6	0.8	1.25	1.6	22.2	1010	1000
27x1.5	0.6	1.0	1.6	1.7	26.7	1495	1000
37x1.5	0.6	1.0	1.6	1.8	29.2	1800	500
48x1.5	0.6	1.0	1.6	1.9	32.9	2195	500

Size	Nominal Thickness of PVC insulation	Nominal Thickness of PVC bedding	Nominal steel wire diameter.	Nominal Thickness of outer sheath	Approx. overall diameter.	Approx. weight	Standard packing
mm ²	mm	mm	mm	mm	mm	Kg/Km	meters
2x2.5	0.7	0.8	0.9	1.4	13.6	370	1000
3x2.5	0.7	0.8	0.9	1.4	14.1	390	1000
4x2.5	0.7	0.8	0.9	1.4	15.0	450	1000
5x2.5	0.7	0.8	0.9	1.5	16.3	575	1000
7x2.5	0.7	0.8	1.25	1.5	18	710	1000
12x2.5	0.7	0.8	1.25	1.6	22.4	1020	1000
19x2.5	0.7	1.0	1.6	1.7	26.6	1535	1000
27x2.5	0.7	1.0	1.6	1.8	30.7	2000	1000
37x2.5	0.7	1.0	1.6	1.9	34.0	2445	500
48x2.5	0.7	1.2	2.0	2.1	39.5	3330	500

Size	Nominal Thickness of PVC insulation	Nominal Thickness of PVC bedding	Nominal steel wire diameter.	Nominal Thickness of outer sheath	Approx. overall diameter.	Approx. weight	Standard packing
mm ²	mm	mm	mm	mm	mm	Kg/Km	meters
2x4	0.8	0.8	0.9	1.4	15.1	460	1000
3x4	0.8	0.8	0.9	1.4	15.8	490	1000
4x4	0.8	0.8	1.25	1.5	17.8	680	1000
5x4	0.8	0.8	1.25	1.5	19.0	775	1000
7x4	0.8	0.8	1.25	1.6	20.5	925	1000
12x4	0.8	1.0	1.6	1.7	26.8	1555	1000
19x4	0.8	1.0	1.6	1.8	30.5	2060	1000
27x4	0.8	1.2	2.0	2.0	37.1	3030	1000
37x4	0.8	1.2	2.0	2.1	40.8	3700	500
48x4	0.8	1.2	2.0	2.2	46.0	4535	500

Core identification:

2cores : Red, Black
 3cores : Red, yellow, blue
 4cores : Red, yellow, blue, black
 5cores : Red, yellow, blue, black, green
 6cores & above : black core insulation with white numerals

Tolerance:

Overall diameter : ± 5%
 Packing : ± 5%

Note: 1) Based on special request solid (re)conductors can also be provided

2) Based on special request for 6cores and above, white cores with black printed numerals can also be provided

3) Cable with one core Green/Yellow can also be provided based on special request



Drum Handling Instructions

National Cables Industry Cables and Conductors should be installed by trained personnel in accordance with good engineering practices, recognized codes of practice, statutory local requirements, IEE wiring regulations and where relevant, in accordance with any specific instructions issued by the company. Cables are often supplied in heavy cable reels and handling these reels can constitute a safety hazard. In particular, dangers may arise during the removal of steel binding straps and during the removal of retaining battens and timbers which may expose projecting nails.

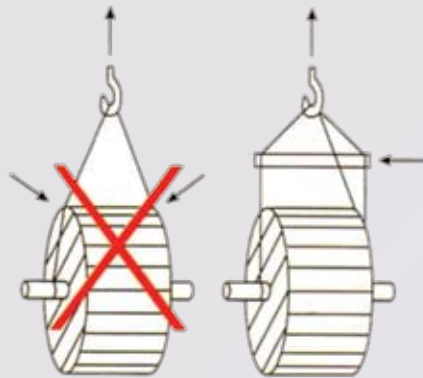

Lifting cable drums using crane.



Do not lay drums flat on their sides, use proper stops to prevent drums rolling.

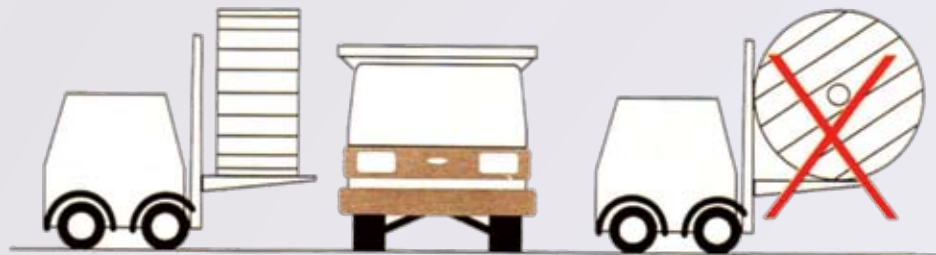

Lift drums on and from Trucks correctly.

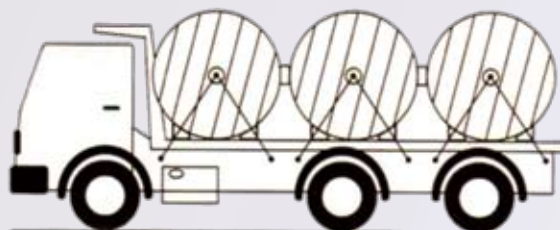

Secure drums adequately before transportation.



Roll in the direction shown by the arrow.



NATIONAL
CABLES
INDUSTRY

NCI

الوطنية
لصناعة
الكابلات

Committed Quality for our Customers

FIRE RESISTANT CABLES NCI - FP

INNOVATIVE

PROCESSES AND

TECHNOLOGY STRATEGIES



INDEX

Introduction	02
Test Equipment	03
1 Core FR Cables	06
2 Core FR Cables	07
3 Core FR Cables	08
4 Core FR Cables	09

INTRODUCTION

Power supply is required to be maintained in critical application services for limited time during fire in, schools, hospitals, stadiums, airports, theatres, multiplexes, hotels, high rise buildings, power stations transit systems and other large public buildings to avoid loss of visibility caused by smoke and acid evolved from burning cable materials which can cause panic and create serious problems when evacuating personnel. Circuit integrity is of utmost importance and power supply to equipment is to be maintained during fire for fire fighting devices, sprinkler systems essential fire detection and alarm systems and evacuations systems for safeguarding human life and protecting equipment.

NCI Fire Resistant Wires and Cables provide robust fire resistant wiring system which in addition to maintaining circuit integrity during fire, produce very low levels of smoke and almost no acidic emissions thus safeguarding human life and protecting vital equipment.

NCI-FP1 Fire Resistant 600/1000 V wires are suitable for use in metallic conduits, trunking where electrical circuit integrity is of utmost importance. These are ideal for emergency lighting, fire detection and fire alarm circuits for systems that do not require twisted pairs or a built-in metallic screen.

NCI's CU/MICA/LSZH-FP1 600/1000 V wires meet Fire tests when tested in conduits as per BS 6387 (950°C for 3 hours), Meets Fire tests as per IEC 60331-21 with enhanced temperature (950°C, 90 minutes + 15 minutes cool down), meet acid gas emission requirements (<0.5%) when tested as per BS EN 60754, meet smoke emission requirements (>70% transmittance) when tested as per BS EN 61034. NCI-FP1 wires are certified by Loss Prevention Certification Board (LPCB).

NCI-FP armoured cables are manufactured from specially formulated Low Smoke and Zero Halogen Compounds and cables comply to BS 7846 Category F2 type and are certified by Loss Prevention Certification Board (LPCB) and satisfy CWZ requirements of BS 6387. NCI-FP cables are manufactured under Quality Management Systems Certified by BASEC and LPCB.

This catalog contains information on National Cables Industry Fire Resistant Wires and Cables with Copper Conductors, MICA Glass Primary Insulation, Low Smoke XLPE Insulation, Armoured/Unarmoured single and multicore cables. Each section contains appropriate technical details and constructional data.

SALIENT FEATURES:

Circuit Integrity: Maintains Circuit Integrity for 3 hours under fire conditions - Category CWZ.

Smoke emission: Minimum 70% transmittance as per BS EN 61034.

Acid gas emission: Zero Halogen < 0.5% acid gas generation as per BS EN 60754.

CORE IDENTIFICATION

As per UAE Local regulations the following colour code is used. However, special colour code as per BS 7846 can be provided based on special request.

Two Core: RED, BLACK

Three Core: RED, YELLOW, BLUE

Four Core: RED, YELLOW, BLUE, BLACK

Current rating tabulated are based on a ambient temperature of 30°C. for other ambient temperatures, the following rating factors are to be applied:



TEST EQUIPMENT

De-rating factors for different air temperatures

Ambient Temperature	25	30	35	40	45	50	55	60	65	70
Rating Factor	1.04	1.0	0.96	0.91	0.87	0.82	0.76	0.71	0.65	0.58

NCI- FP cables meet Flame propagation tests as per BS EN 60332-1, BS EN 60332 - 3 - 24, Acid emission as per BS EN 60754 (actual less than 0.1%), Smoke Emission tests as per BS EN 61034 with minimum 70% transmittance. CWZ Fire Resistance tests at 600/1000 V as per BS 6387.

Fire properties: Protocol C - 950°C for 3 hours as per BS 6387.

Fire with Water: Protocol W - 650°C for 15 minutes as per BS 6387

Fire with Mechanical Shock: Protocol Z – 950°C for 15 minutes as per BS 6387.

Fire resistant 600/1000 V, 2 Core, 3 core and 4 Core 1.5 mm² to 400 mm² NCI-FP cables are suitable for applications requiring circuit integrity during fire. Since these cables are used in critical applications, process approval (FPC – Factory Production Control from LPCB) and LPCB certification are vital to ensure necessary performance and civil defense approval.

Fire Propagation Test On Single Cable

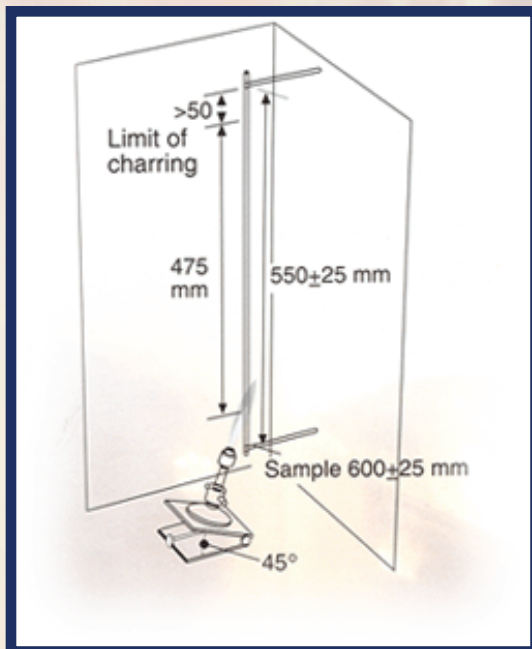

TEST EQUIPMENT

Flame Propagation Test On Multiple Cables

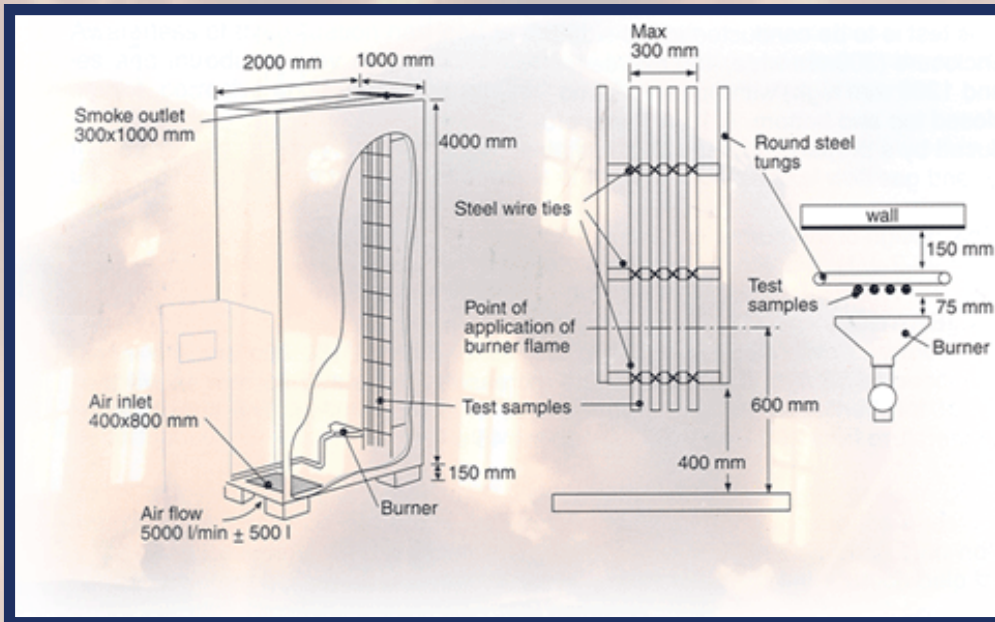

Fire Resistance Test 950 °C – 3 Hours

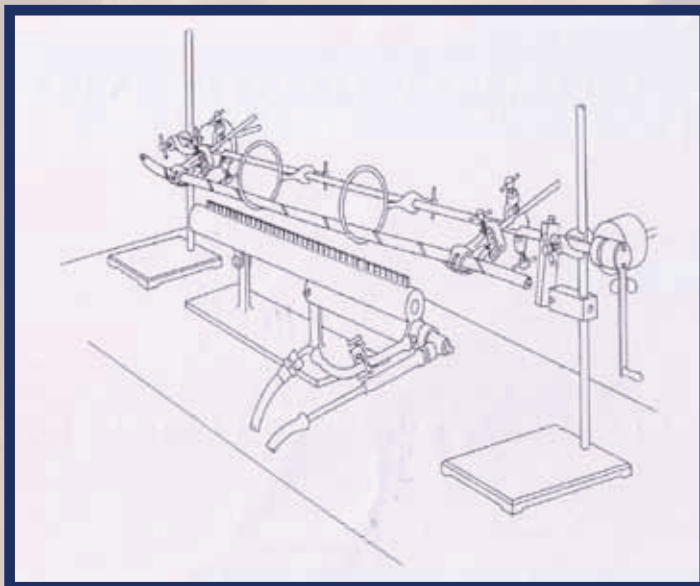

TEST EQUIPMENT

Smoke Emission Test

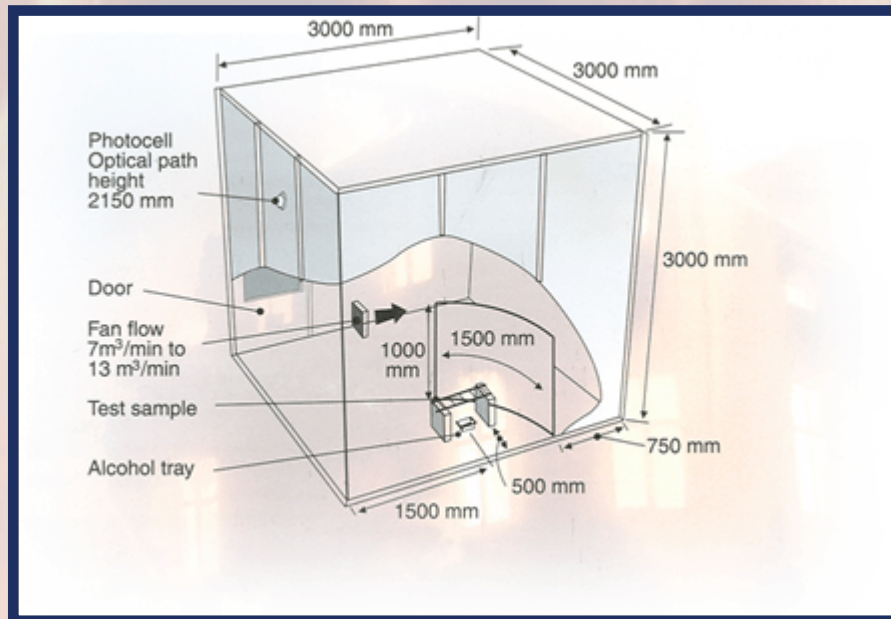

Determination of Emission of Acid Gas

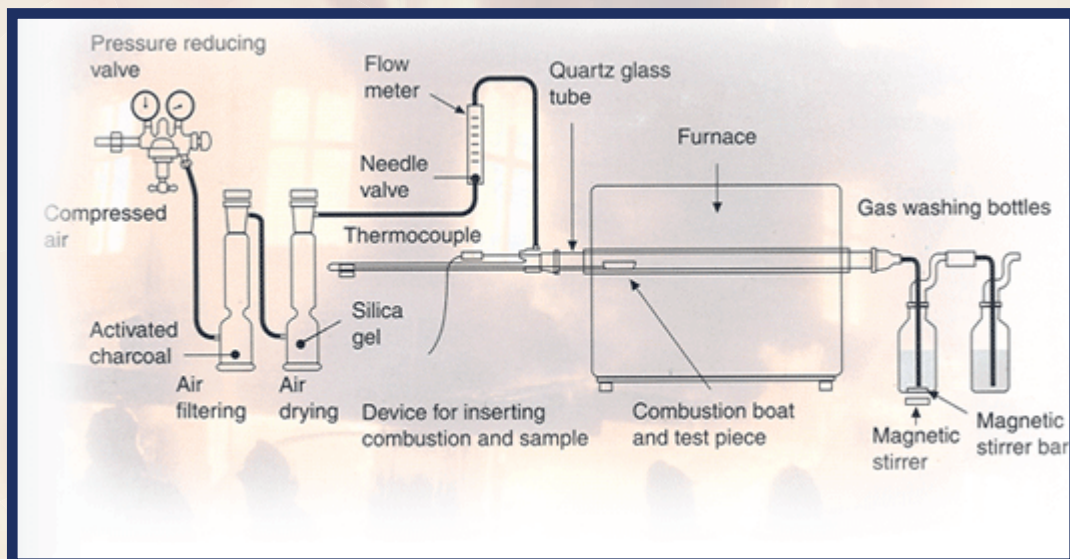

1 CORE FR 600/1000 Volts

600/1000 VOLTS 1 CORE FIRE RESISTANT CABLES TO BS 6387, IEC 60331-21 (STRANDED COPPER CONDUCTOR), NCI-FP1

Cross Sectional Area	Number Of Strands	Approx. Conductor Diameter	Average Insulation Thickness	Approx. Overall Diameter	Approx. Weight	Maximum Conductor D.C. Resistance at 20°	Current Rating (1Ø AC)	Current Rating (3Ø AC)	Voltage Drop (1Ø AC)	Voltage Drop (3Ø AC)
mm ²	No.	mm	mm	mm	Kg/Km	Ohm/km	Amps	Amps	mV/A/m	mV/A/m
1x 1.5 rm	7	1.56	0.7	4.0	30	12.1	23	20	31	27
1 x 2.5 rm	7	2.01	0.8	5.0	40	7.41	31	28	19	16
1 x 4 rm	7	2.55	0.8	5.5	60	4.61	42	37	12	10
1 x 6 rm	7	3.12	0.8	6.0	80	3.08	54	48	7.9	6.8
1 x 10 rm	7	4.01	1.0	7.0	125	1.83	75	66	4.7	4
1x 16 rm	7	5.03	1.0	8.0	180	1.15	100	88	2.9	2.5
1 x 25 rm	7	6.30	1.2	10.0	280	0.727	133	117	1.9	1.65
1 x 35 sm	7	7.44	1.2	11.0	375	0.524	164	144	1.35	1.15
1 x 50 rmc	19	8.10	1.4	12.0	500	0.387	198	175	1.05	0.9
1 x 70 rmc	19	9.70	1.4	14.0	700	0.268	253	222	0.75	0.65
1 x 95 rmc	19	11.40	1.6	16.0	950	0.193	306	269	0.58	0.5
1x 120 rmc	37	12.90	1.6	17.0	1185	0.153	354	312	0.48	0.42
1 x 150 rmc	37	14.30	1.8	19.0	1450	0.124	393	342	0.43	0.37
1 x 185 rmc	37	16.0	2.0	21.0	1815	0.0991	449	384	0.37	0.32
1 x 240 rmc	61	18.40	2.2	24.0	2375	0.0754	528	450	0.33	0.29
1 x 300 rmc	61	20.40	2.4	26.0	2965	0.0601	603	514	0.31	0.27
1x400 rmc	61	23.20	2.6	29.0	3765	0.047	683	584	0.29	0.25
1x500 rmc	61	26.70	2.8	33.0	4800	0.0366	783	666	0.28	0.24
1x600 rmc	61	30.40	2.8	37.0	6140	0.283	900	764	0.27	0.23

Current rating based on installation "enclosed in conduit on a wall or in trunking" in line with BS 7671 (IEE Wiring Regulations). Laying condition: 30° C ambient temperature & 90°C operating temperature. For other ambient temperatures appropriate rating factors should be applied.

Temperature Rating Factors

Ambient Temperature in °C	25	30	35	40	45	50	45	60
Rating Factor	1.02	1.00	0.96	0.91	0.87	0.82	0.76	0.71

Correction Factors for Grouping

Number of Circuits	2	3	4	5	6	7	8	9
Rating Factor	0.80	0.70	0.65	0.60	0.57	0.54	0.52	0.50

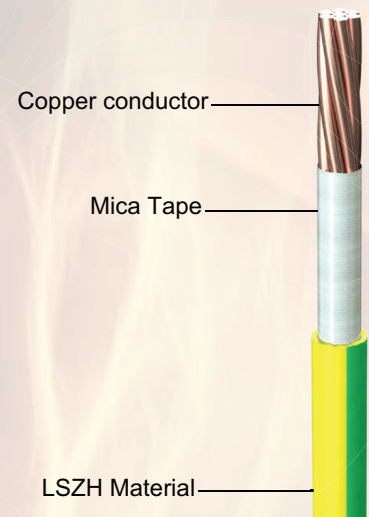

2 CORE FR 600/1000 Volts

600/1000 Volts 2 CORE FIRE RESISTANT ARMoured CABLES TO BS 7846 (STRANDED COPPER CONDUCTOR)

Cross Sectional Area	Number Of Strands	Approx. Conductor Diameter	Average Insulation Thickness	Nominal Steel Wire Diameter	Nominal Sheath Thickness	Approx. Overall Diameter	Approx. Weight	Maximum Conductor d.c. Resistance at 20°C	Current rating in Air @ 30°C
mm ²	No.	mm	mm	mm	mm	mm	Kg/Km	Ohm/Km	Amps
2x 1.5 rm	7	1.56	0.6	0.9	1.3	15.0	380	12.1	29
2 x 2.5 rm	7	2.01	0.7	0.9	1.4	16.0	475	7.41	39
2 x 4 rm	7	2.55	0.7	0.9	1.4	17.0	550	4.61	52
2 x 6 rm	7	3.12	0.7	0.9	1.4	18.0	620	3.08	66
2 x 10 rm	7	4.01	0.7	0.9	1.5	20.0	780	1.83	90
2 x 16 rmc	7	4.70	0.7	1.25	1.5	22.0	1065	1.15	115
2 x 25 rm	7	6.30	0.9	1.25	1.6	26.0	1480	0.727	152
2 x 35 rmc	7	6.9	0.9	1.6	1.7	29.0	1935	0.524	188
2 x 50 sm	19	Sectoral	1.0	1.6	1.8	27.0	1910	0.387	228
2 x 70 sm	19	Sectoral	1.1	1.6	1.9	30.0	2450	0.268	291

Note: For Electrical parameters, please refer to NCI Electrical Guide.

Colour of Insulation: Red,Black

BS 7846 colour code shall be provided only based on special request
Colour code: Brown, Blue

rm - Round multi stranded
rmc - Round multi stranded compacted
sm - Sectoral shaped compacted

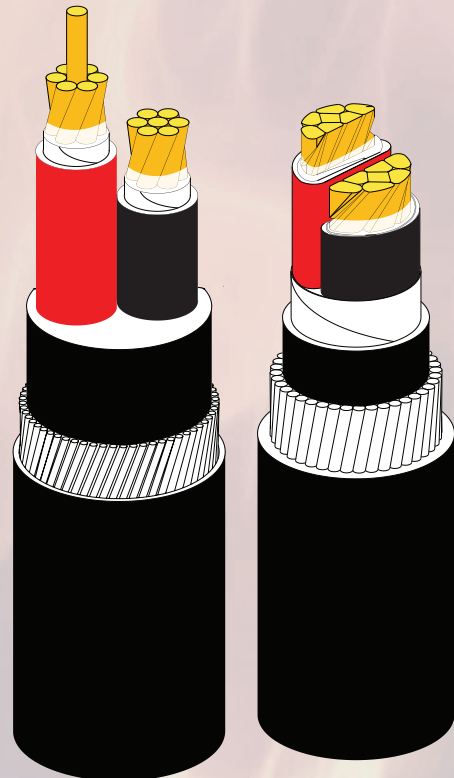

3 CORE FR 600/1000 Volts

600/1000 Volts 3 CORE FIRE RESISTANT ARMoured CABLES TO BS 7846 (STRANDED COPPER CONDUCTOR)

Cross Sectional Area	Number Of Strands	Approx. Conductor Diameter	Average Insulation Thickness	Nominal Steel Wire Diameter	Nominal Sheath Thickness	Approx. Overall Diameter	Approx. Weight	Maximum Conductor d.c. Resistance at 20°C	Current rating in Air @ 30°C
mm ²	No.	mm	mm	mm	mm	mm	Kg/Km	Ohm/Km	Amps
3x 1.5 rm	7	1.56	0.6	0.9	1.3	15.0	415	12.1	25
3 x 2.5 rm	7	2.01	0.7	0.9	1.4	17.0	500	7.41	33
3 x 4 rm	7	2.55	0.7	0.9	1.4	18.0	600	4.61	44
3 x 6 rm	7	3.12	0.7	0.9	1.4	19.0	700	3.08	56
3 x 10 rm	7	4.01	0.7	1.25	1.5	23.0	1015	1.83	78
3x 16 rmc	7	4.70	0.7	1.25	1.6	24.0	1250	1.15	99
3 x 25 rm	7	6.30	0.9	1.6	1.7	30.0	1930	0.727	131
3 x 35 sm	7	Sectoral	0.9	1.6	1.8	28.0	2050	0.524	162
3 x 50 sm	19	Sectoral	1.0	1.6	1.8	31.0	2540	0.387	197
3 x 70 sm	19	Sectoral	1.1	1.6	1.9	34.0	3300	0.268	251
3 x 95 sm	19	Sectoral	1.1	2.0	2.1	39.0	4490	0.193	304
3x 120 sm	37	Sectoral	1.2	2.0	2.2	42.0	5375	0.153	353
3 x 150 sm	37	Sectoral	1.4	2.5	2.3	48.0	6850	0.124	406
3 x 185 sm	37	Sectoral	1.6	2.5	2.4	52.0	8200	0.0991	463
3 x 240 sm	61	Sectoral	1.7	2.5	2.6	57.0	10160	0.0754	546
3 x 300 sm	61	Sectoral	1.8	2.5	2.7	62.0	12265	0.0601	628
3x400 sm	61	Sectoral	2.0	2.5	2.9	69.0	15165	0.047	728

Note: For Electrical parameters, please refer to NCI Electrical Guide.

Colour of Insulation: Red, Yellow, Blue

BS 7846 colour code shall be provided only based on special request

Colour code: Brown, Black, Grey

rm - Round multi stranded

rmc - Round multi stranded compacted

sm - Sectoral shaped compacted

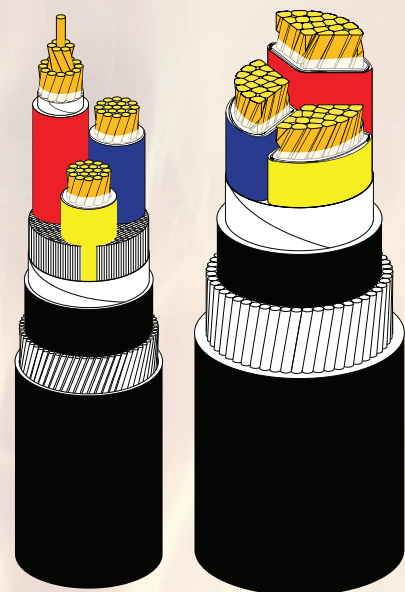

4 CORE FR 600/1000 Volts

600/1000 Volts 4 CORE FIRE RESISTANT ARMoured CABLES TO BS 7846 (STRANDED COPPER CONDUCTOR)

Cross Sectional Area	Number Of Strands	Approx. Conductor Diameter	Average Insulation Thickness	Nominal Steel Wire Diameter	Nominal Sheath Thickness	Approx. Overall Diameter	Approx. Weight	Maximum Conductor d.c. Resistance at 20°C	Current rating in Air @ 30°C
mm ²	No.	mm	mm	mm	mm	mm	Kg/Km	Ohm/Km	Amps
4x 1.5 rm	7	1.56	0.6	0.9	1.3	16.0	470	12.1	25
4 x 2.5 rm	7	2.01	0.7	0.9	1.4	18.0	585	7.41	33
4x 4 rm	7	2.55	0.7	0.9	1.4	19.0	700	4.61	44
4 x 6 rm	7	3.12	0.7	1.25	1.5	21.0	950	3.08	56
4 x 10 rm	7	4.01	0.7	1.25	1.5	23.0	1235	1.83	78
4x 16 rmc	7	4.70	0.7	1.25	1.6	26.0	1465	1.15	99
4 x 25 sm	7	Sectoral	0.9	1.6	1.7	27.0	2000	0.727	131
4 x 35 sm	7	Sectoral	0.9	1.6	1.8	30.0	2485	0.524	162
4 x 50 sm	19	Sectoral	1.0	1.6	1.9	33.0	3130	0.387	197
4 x 70 sm	19	Sectoral	1.1	2.0	2.10	39.0	4435	0.268	251
4 x 95 sm	19	Sectoral	1.1	2.0	2.20	42.0	5610	0.193	304
4x 120 sm	37	Sectoral	1.2	2.5	2.30	48.0	7180	0.153	353
4 x 150 sm	37	Sectoral	1.4	2.5	2.4	52.0	8575	0.124	406
4 x 185 sm	37	Sectoral	1.6	2.5	2.6	57.0	10330	0.0991	463
4 x 240 sm	61	Sectoral	1.7	2.5	2.7	63.0	12950	0.0754	546
4 x 300 sm	61	Sectoral	1.8	2.5	2.9	69.0	15670	0.0601	628
4x400 sm	61	Sectoral	2.0	3.15	3.2	79.0	20435	0.047	728

Note: For Electrical parameters, please refer to NCI Electrical Guide.

Colour of Insulation: Red, Yellow, Blue, Black

BS 7846 colour code shall be provided only based on special request
Colour code: Blue, Brown, Black, Grey

rm - Round multi stranded
rmc - Round multi stranded compacted
sm - Sectoral shaped compacted

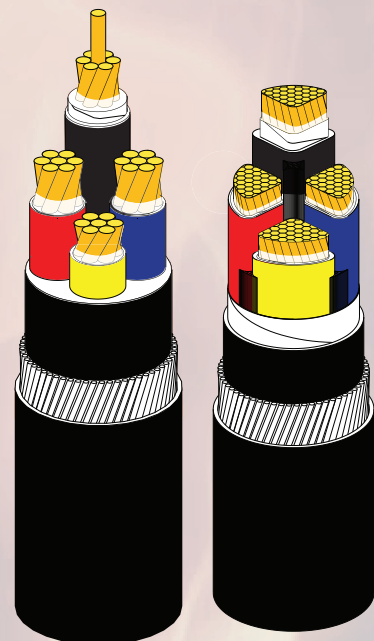

DRUM HANDLING INSTRUCTION

National Cable Industry Cables and Conductors should be installed by trained personnel in accordance with good engineering practices, recognized codes of practice, statutory local requirements, IEE wiring regulations and where relevant, in accordance with any specific instructions issued by the company. Cables are often supplied in heavy cable reels and handling these reels can constitute a safety hazard. In particular, dangers may arise during the removal of steel binding straps and during the removal of retaining battens and timbers which may expose projecting nails.

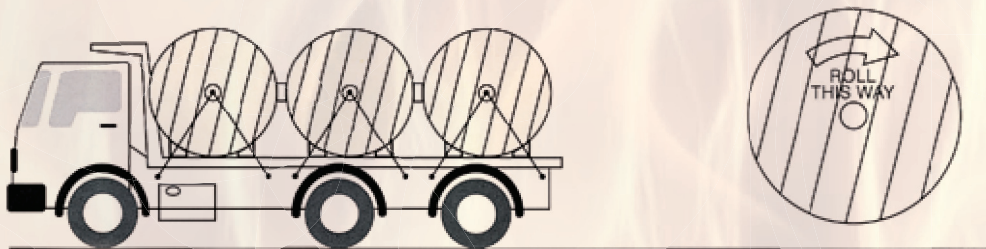
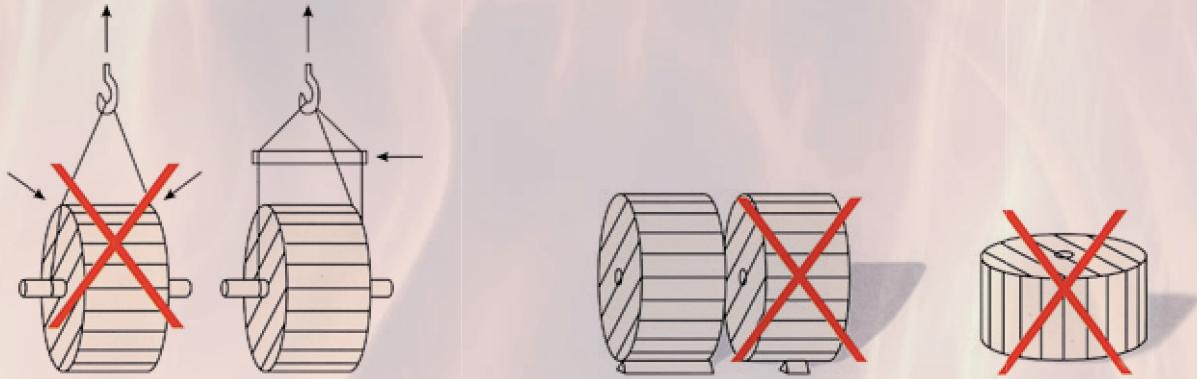



P.O. Box: 27472 Sharjah U.A.E.
Tel.: +971 6 5311888 (8 Lines) Fax.: +971 6 5311577
e-mail: n_c_i@emirates.net.ae website: www.nci.ae